

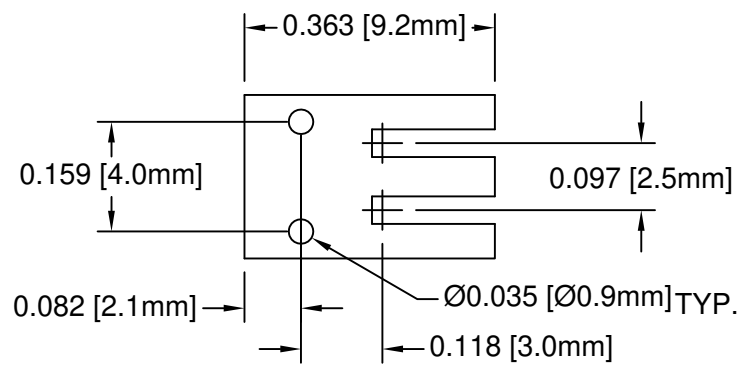

REV.	DESCRIPTION	DATE	APPROVED
A	Engineering Release	02/19/04	M. C.
B	Removed Material Code	05/28/16	J. C.

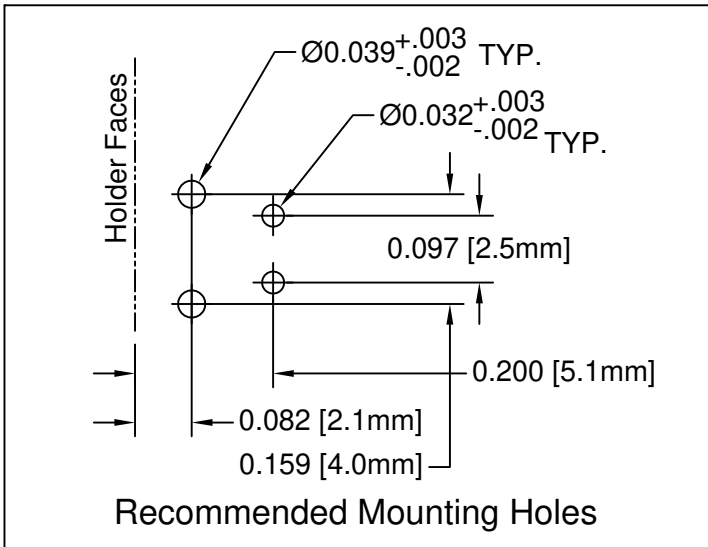
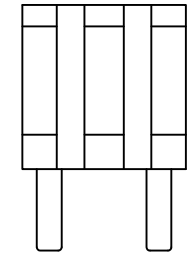
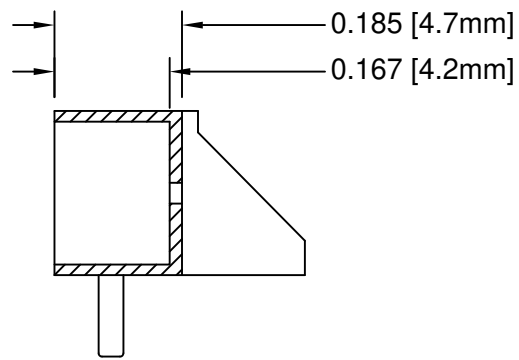
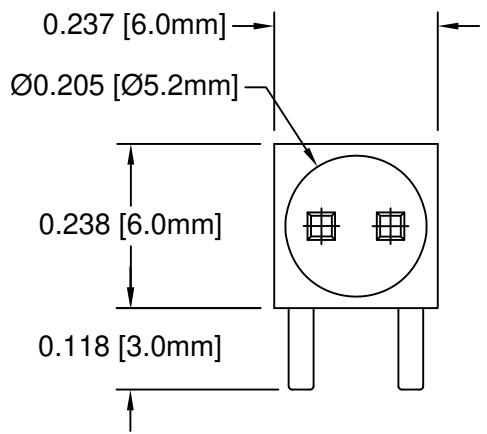
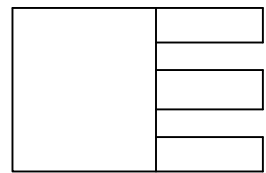
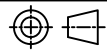

STANDARD TOLERANCE (UNLESS OTHERWISE SPECIFIED)		 4 THOMAS, IRVINE, CA. 92618 TEL: (949) 951-8808 FAX: (949) 951-3974	
DECIMALS	ANGULAR		
.X ± .1	X° ± 1°	 TITLE: T-1 (3mm) LED HOLDER	
.XX ± .01			DESIGNED: S. Irving DATE: 12/03/98
.XXX ± .005			CHECKED: M. Chen DATE: 02/19/04
		PART NO: H-178C-LP	REVISION: B
		CAGE CODE : 32559	SHEET # 1 OF 1
CAD GENERATED DOCUMENT. DO NOT MEASURE DRAWING.			

- 2. MATERIAL: NYLON 6/6, 94V-0, BLACK.
- 1. GENERAL SPECIFICATIONS: BIVAR MOLDED COMPONENT SPECIFICATION BV00-E101.