

THIS DRAWING IS UNPUBLISHED. RELEASED FOR PUBLICATION
 © COPYRIGHT BY TYCO ELECTRONICS CORPORATION. ALL RIGHTS RESERVED.

LOC	DIST	REVISIONS			
P	LTR	DESCRIPTION	DATE	DWN	APVD
G	14	A1	REVISED PER ECR-08-004464	03MAR08	HMR JR

△ 1 STAMP AMP 16-14* APPROX AS SHOWN

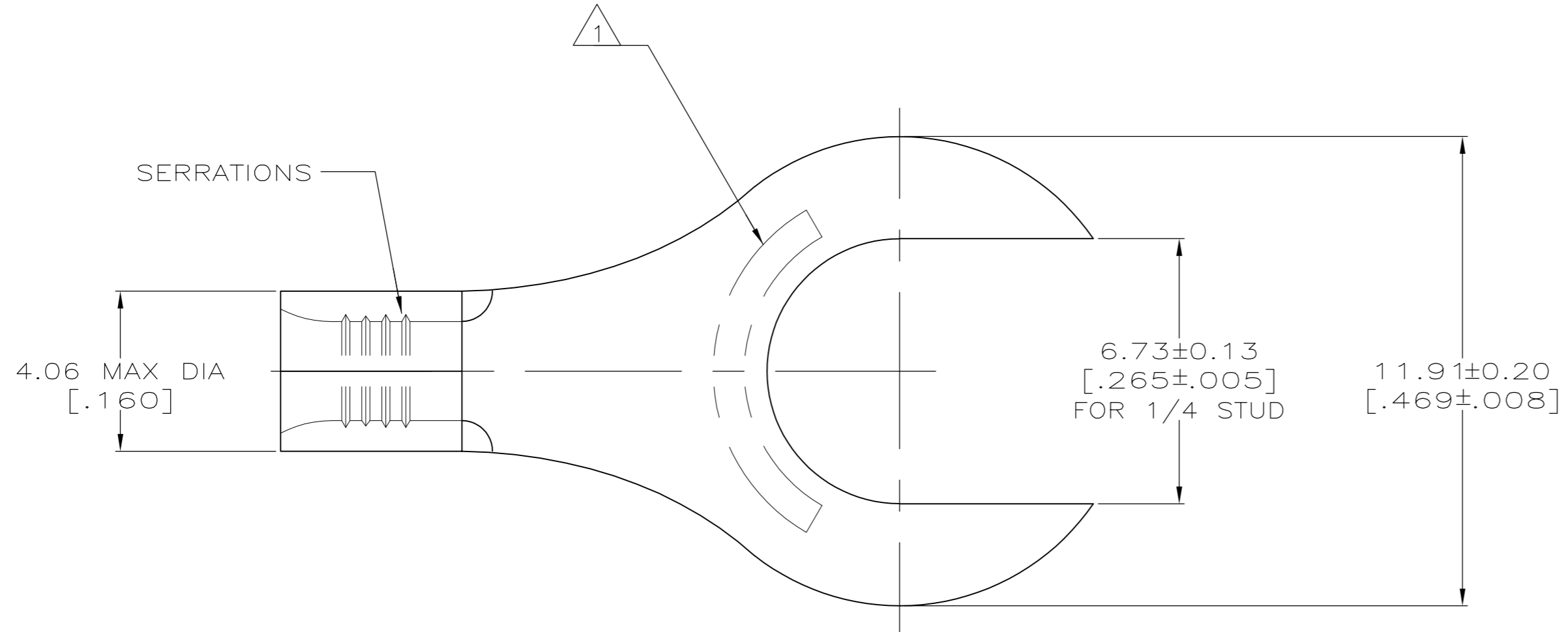

AMP WIRE RANGE	Listed FILE E13288	LR7189 Certified
16-14 AWG STRANDED	16-14 AWG STRANDED	NOT CERTIFIED

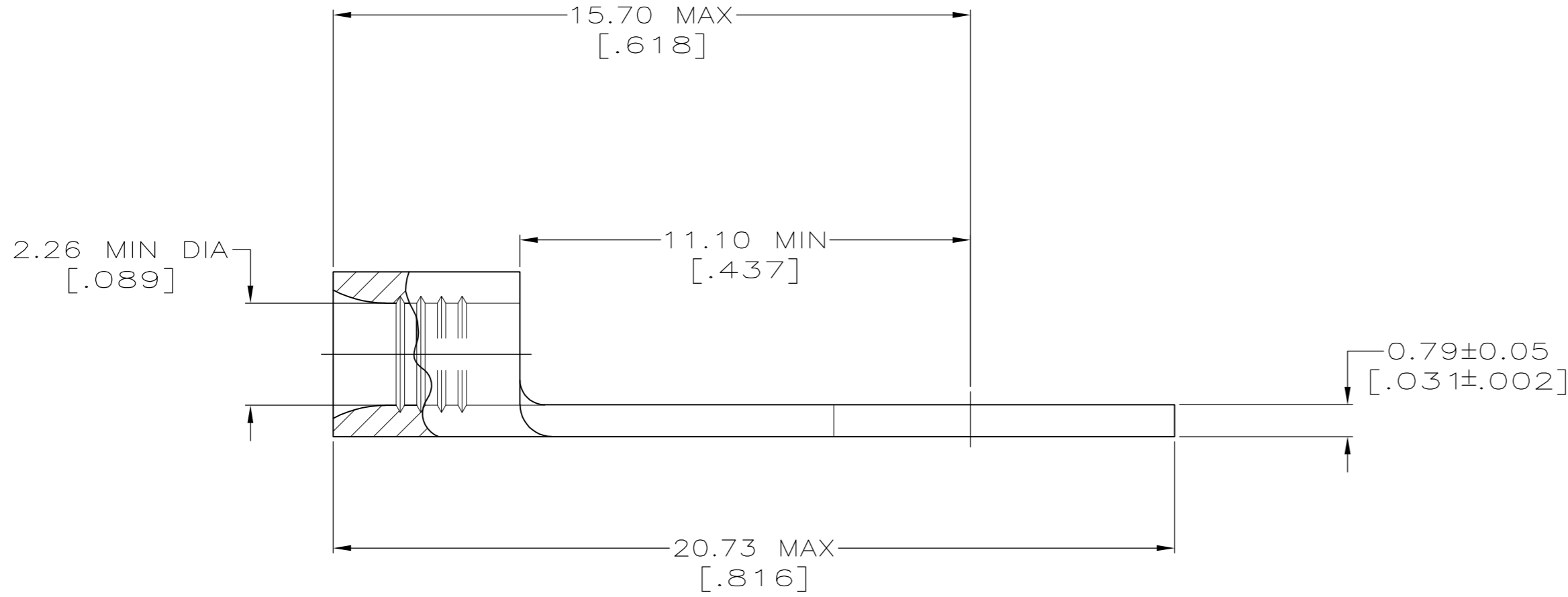

36216
PART NO

MAX RECOMMENDED OPERATING TEMPERATURE	170° C MAX
VOLTAGE RATING	NOT APPLICABLE
WIRE CROSS SECTIONAL AREA RANGE	1.04-2.62mm ² [2,050-5,180] CIR MILLS STRANDED

THIS DRAWING IS A CONTROLLED DOCUMENT.		DWN TA BRINKMAN 2-24-93	Tyco Electronics Corporation Harrisburg, PA 17105-3608	
DIMENSIONS: INCHES		CHK DA PATTERSON 2-24-93		
TOLERANCES UNLESS OTHERWISE SPECIFIED:		APVD DE MILLER 2-24-93	NAME TERMINAL, SLOTTED RING TONGUE, BUDGET	
0 PLC ± - 1 PLC ± - 2 PLC ± - 3 PLC ± - 4 PLC ± - ANGLES ± -		PRODUCT SPEC -	SIZE A2	
MATERIAL COPPER PER ASTM B-152 ANNEALED		FINISH TIN PLATE 0.00254[.000100] MIN PER ASTM B-545.	APPLICATION SPEC -	CAGE CODE 00779
		WEIGHT -	DRAWING NO C=36216	RESTRICTED TO -
		CUSTOMER DRAWING	SCALE 8:1	SHEET 1 of 1
			REV A1	