

MATERIALS AND FINISHES

BODY, CRIMP TUBE, JAM NUT: BRASS
PLATED NICKEL

CONTACT: BERYLLIUM COPPER
PLATED GOLD

INSULATOR: TEFLON

LOCK WASHER: PHOSPHOR BRONZE
PLATED NICKEL

SHINK TUBE: VERSAFIT OR EQUIVALENT

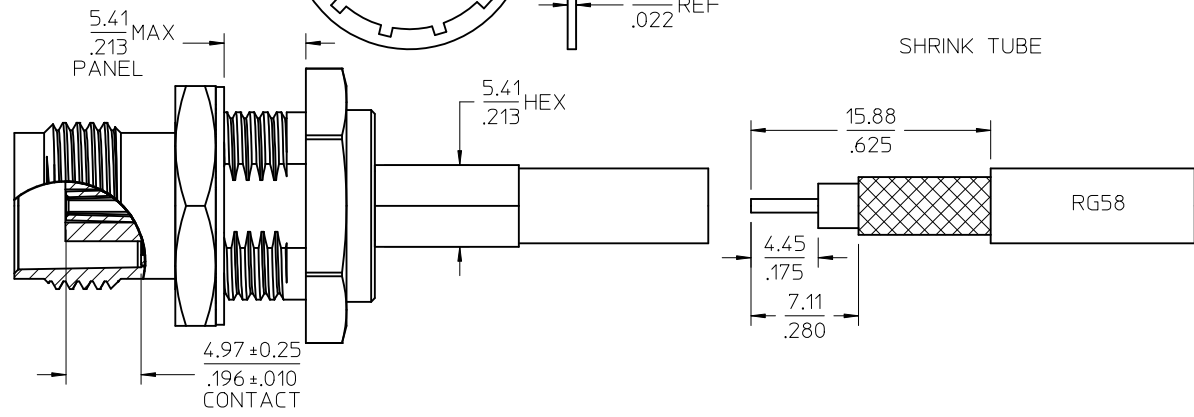
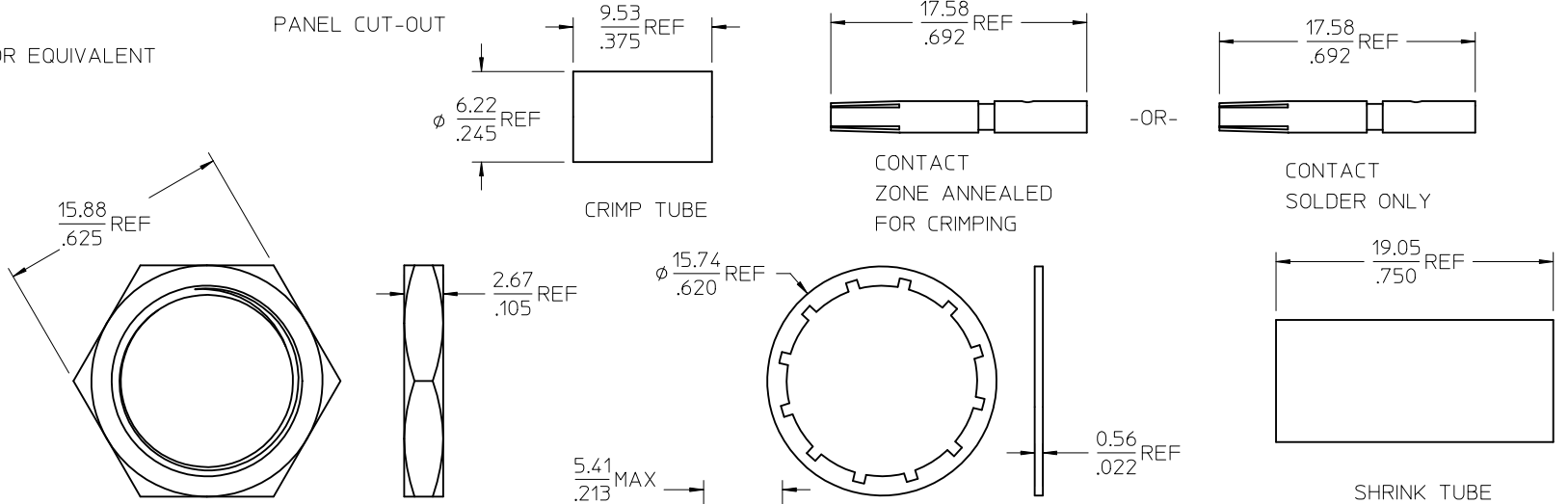
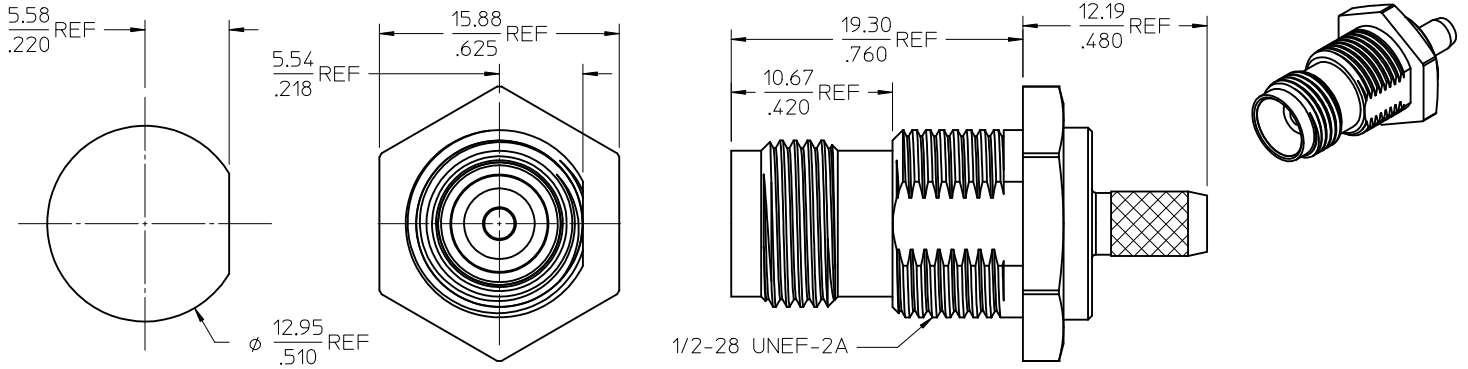

73216-0103	CRIMP/SOLDER	NOT INCLUDED	ONE PER BAG
73216-0102	CRIMP/SOLDER	INCLUDED	STANDARD
73216-0101	SOLDER ONLY	NOT INCLUDED	STANDARD
73216-0100	CRIMP/SOLDER	NOT INCLUDED	STANDARD
PART NO.	CONTACT	SHRINK TUBE	PACKAGING

<p>CHG: "PACKAGING" WAS "FINISH" IN TABLE</p> <p>EC NO: URF2012-0398</p> <p>DRW: BOMALLEY 2012/01/10</p> <p>CHKD: AZR 2012/01/10</p> <p>APPR: JMWENER 2012/01/11</p> <p>REV: A2</p>			
---	--	--	--

<p>QUALITY SYMBOLS</p> <p>▽=0</p> <p>▽=0</p>	<p>GENERAL TOLERANCES (UNLESS SPECIFIED)</p> <table border="1"> <tr> <th></th> <th>mm</th> <th>INCH</th> </tr> <tr> <td>4 PLACES</td> <td>± .005</td> <td>± .0002</td> </tr> <tr> <td>3 PLACES</td> <td>± .005</td> <td>± .0002</td> </tr> <tr> <td>2 PLACES</td> <td>± .005</td> <td>± .0002</td> </tr> <tr> <td>1 PLACE</td> <td>± .005</td> <td>± .0002</td> </tr> </table> <p>ANGULAR ± 2°</p>		mm	INCH	4 PLACES	± .005	± .0002	3 PLACES	± .005	± .0002	2 PLACES	± .005	± .0002	1 PLACE	± .005	± .0002	<p>DIMENSION STYLE</p> <p>MM/IN</p>	<p>SCALE</p> <p>DESIGN UNITS</p> <p>METRIC</p>	<p>THIRD ANGLE PROJECTION</p>
			mm	INCH															
4 PLACES	± .005	± .0002																	
3 PLACES	± .005	± .0002																	
2 PLACES	± .005	± .0002																	
1 PLACE	± .005	± .0002																	
<p>DRAFT WHERE APPLICABLE MUST REMAIN WITHIN DIMENSIONS</p>	<p>MATERIAL NO.</p> <p>SEE TABLE</p>	<p>DATE</p> <p>2008/05/09</p>	<p>TITLE</p> <p>TNC JACK BULKHEAD STRAIGHT 50 OHM RG58 TNC-JC, EWR-1499</p>	<p>MOLEX INCORPORATED</p>															
	<p>DOCUMENT NO.</p> <p>SD-73216-010</p>	<p>DATE</p> <p>2008/05/09</p>	<p>APPROVED BY</p> <p>JDW</p>	<p>SHEET NO.</p> <p>1 OF 1</p>															
	<p>THIS DRAWING CONTAINS INFORMATION THAT IS PROPRIETARY TO MOLEX INCORPORATED AND SHOULD NOT BE USED WITHOUT WRITTEN PERMISSION</p>																		