

PART NUMBER	LEAD FREE VERSION	DIM L
7361E0225S05	7361E0225S05LF	90
10013689-001	10013689-001LF	60

**GENERAL :**  
 High cycle life duration smart card connector with landing type contacts mechanism. The landing type connector also provides the feature of recessed contacts when card is not inserted which protects them against vandalism.  
 Smart card for reference purposes only.

**ELECTRICAL PROPERTIES:**  
 Insulation resistance : > 1000MΩ  
 Dielectric withstanding voltage : >750 Vrms  
 Current carrying capacity : Min 10μA, Max 1A  
 Contact resistance : < 100mΩ

**MECHANICAL PROPERTIES :**  
 Operating force : Insertion : F < 10N  
 Withdrawal : 1 < F < 10N  
 Contact Normal force : 0.2 < F < 0.3 for 0.6mm of deflection  
 Durability : 200 000 mating cycles

**MATERIAL :**  
 Head reader : Thermoplastic, Colour Grey, Rated UL94V0  
 Cover : Thermoplastic, Colour Grey, Rated UL94V0  
 Contacts : Copper alloy,  
 Plating : Gold over Ni or equivalent on contact area  
 SnPb over Ni on solder tails (for leaded version)  
 Matte tin over Ni on solder tails (for lead free version)

**ENVIRONMENT :**  
 Operating temperature : -40°C / +85°C  
 Climatic conditions : UTE 93-421

**PACKAGING :**  
 Plastic cavity tray

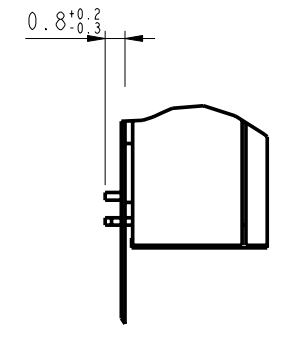
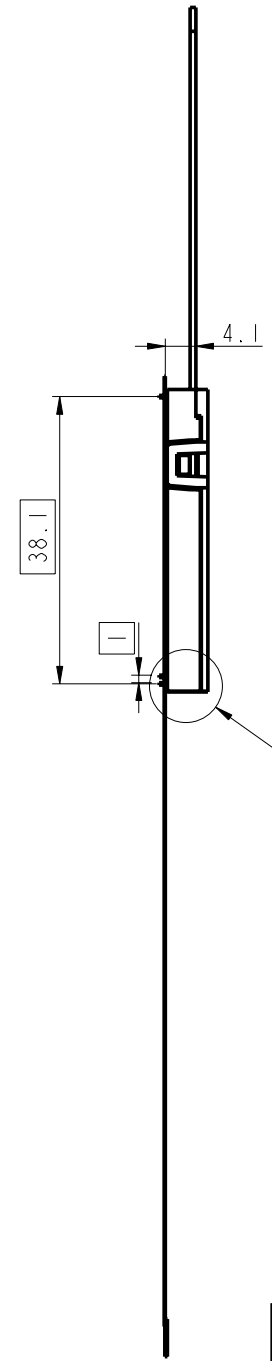
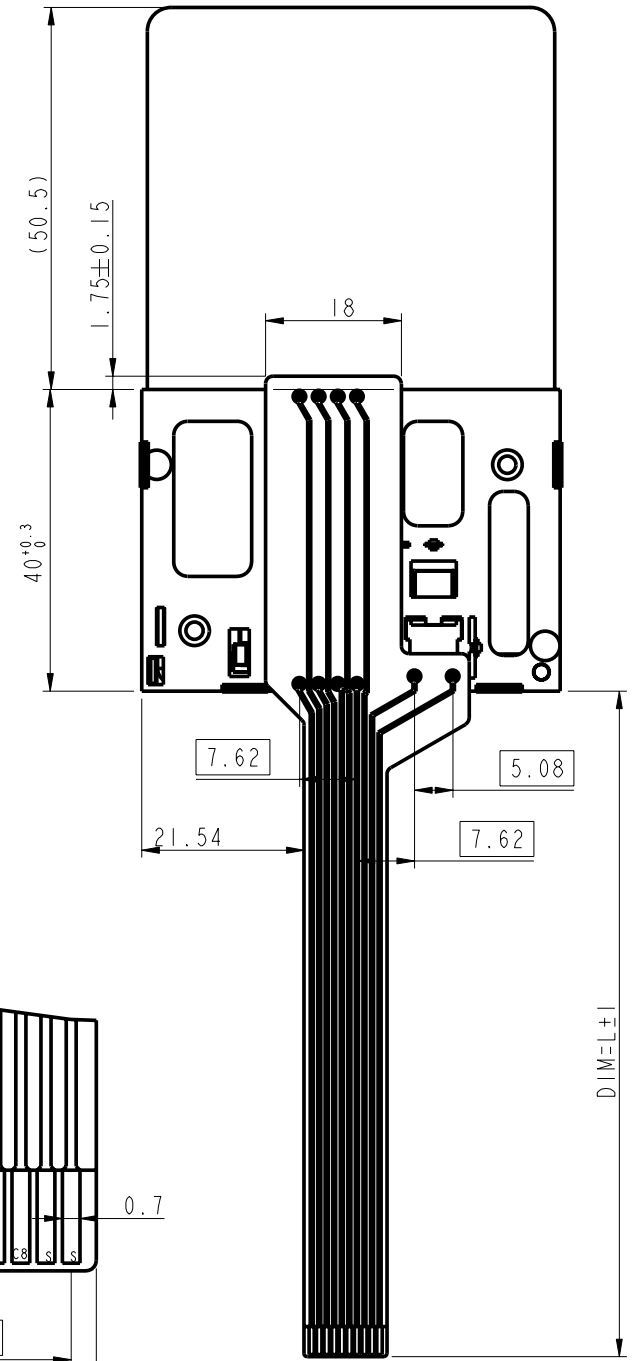
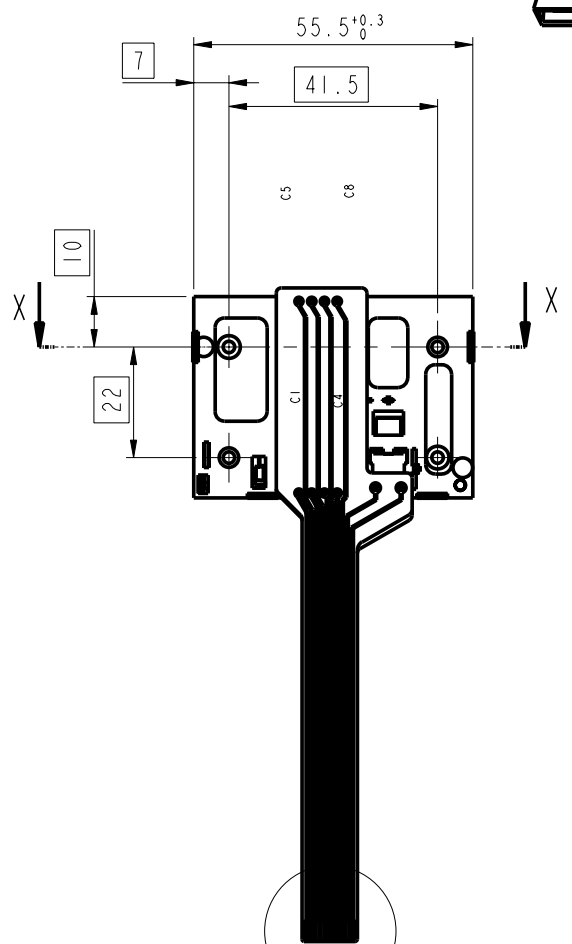
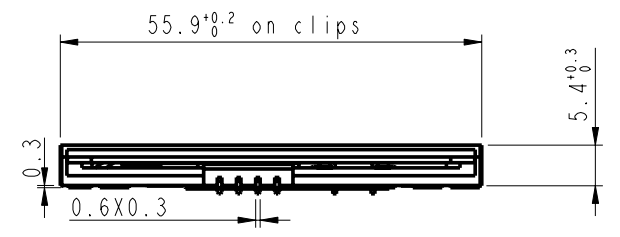
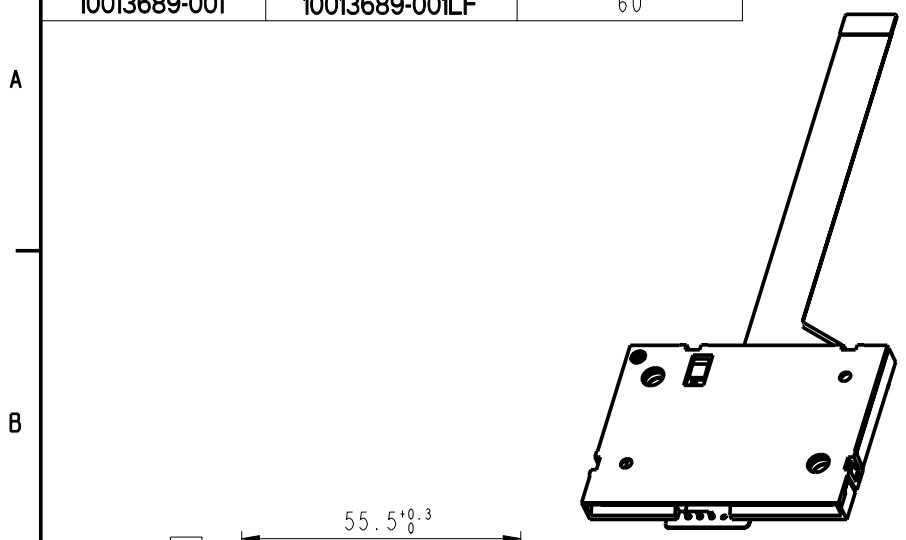

DETAIL B  
SCALE 5:1

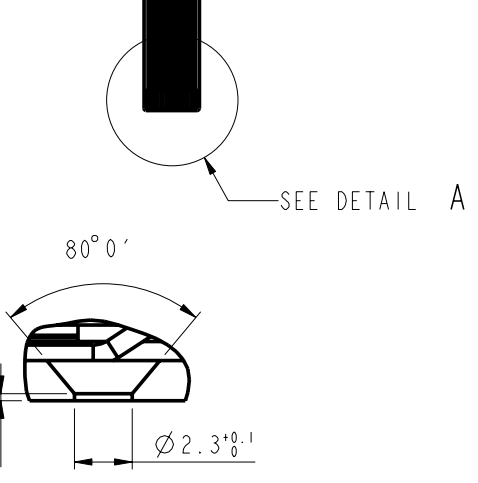

SECTION X-X  
SCALE 5:1

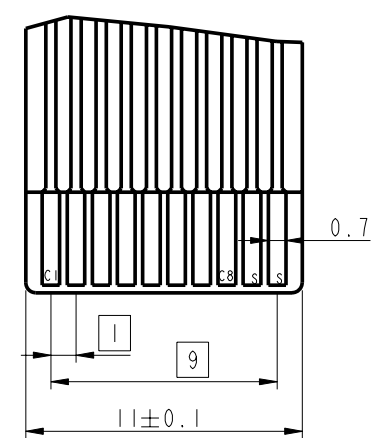

DETAIL A  
SCALE 5:1

**General Tolerances**

0 to 10mm:	±0.1mm
10 to 30mm:	±0.15mm
30 to 60mm:	±0.2mm
60 and more:	±0.3mm

rev	ecn no	dr	date
C	LS2117	JTA	2002/09/04
D	LS3077	MPE	2003/09/17
E	LS3088	MPE	2003/10/10
F	104-0051	DTK	2004/07/17
G	105-0181	NT	2005/10/04
H	105-0078	DTK	2006/06/19
J	109-0013	SSC	2009/01/24

www.fciconnect.com		surface -- ✓	tolerance std	projection	mm
		ISO 1302	ISO 406 ISO 1101	⊕	↔
TOLERANCES UNLESS OTHERWISE SPECIFIED					
Dr	D LEGRAND	2002/04/29	ANGULAR	0.x	±
Eng	F TISSERAND	2002/04/29	LINEAR	0.xx	±
Chr	S.S.CHERIAN	2009/01/24	0° ±°	0.xxx	±
Appr	S.S.CHERIAN	2009/01/24	Product family	MOBILE I/O	Spec ref
E02 FLEX			VJW_53940		Rev. J
SMART CARD READER VXX 27790			-		sheet 1 of 1
catalog no			See Table		

LEAD FREE VERSION:  
 "This product meets European Union Directives and other country regulations as described in GS-22-008"



Copyright FCI