



September 2014

# KA79MXX / LM79MXX

## 3-Terminal 0.5 A Negative Voltage Regulator

### Features

- No External Components Required
- Output Current in Excess of 0.5 A
- Internal Thermal Overload
- Internal Short-Circuit Current Limiting
- Output Transistor Safe Area Compensation
- Output Voltages: -5 V, -12 V

### Description

The KA79MXX / LM79MXX series of three terminal medium current negative voltage regulators are monolithic integrated circuits designed as fixed-voltage regulators. These regulators employ internal current limiting, thermal shutdown, and safe area compensation.

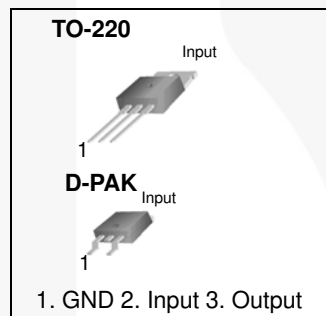

### Ordering Information<sup>(1)</sup>

Product Number	Package	Packing Method	Operating Temperature
KA79M05TU	TO-220 (Dual Gauge)	Rail	0 to +125°C
KA79M05RTM	D-PAK	Tape and Reel	
KA79M05RTF			
KA79M12RTM			
KA79M12RTF			
LM79M05CT	TO-220 (Single Gauge)	Rail	

### Note:

1. Refer to below figure for TM / TF suffix of DPAK packing option.

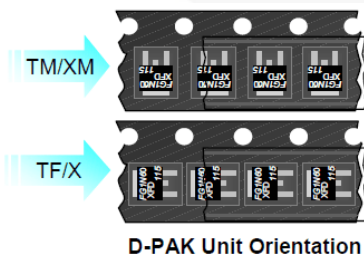

KA79MXX / LM79MXX — 3-Terminal 0.5 A Negative Voltage Regulator

## Block Diagram

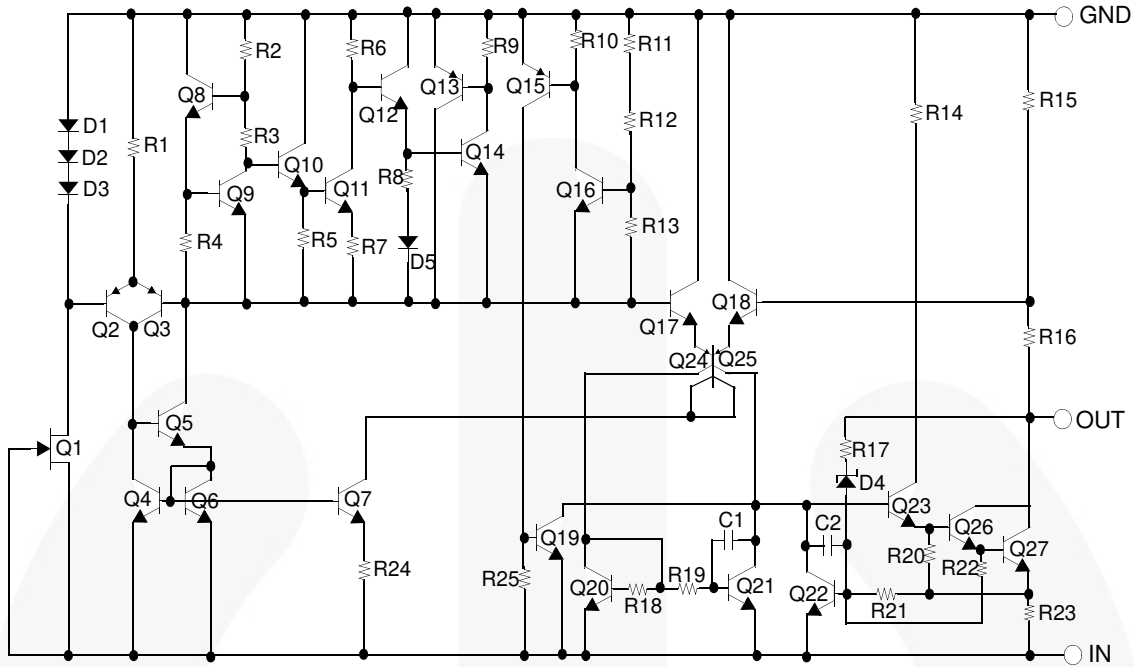

Figure 1. Block Diagram

## Absolute Maximum Ratings

Stresses exceeding the absolute maximum ratings may damage the device. The device may not function or be operable above the recommended operating conditions and stressing the parts to these levels is not recommended. In addition, extended exposure to stresses above the recommended operating conditions may affect device reliability. The absolute maximum ratings are stress ratings only.

Symbol	Parameter	Value	Unit
$V_I$	Input Voltage	$V_O = -5 \text{ V to } -12 \text{ V}$	V
$R_{\theta JC}$	Thermal Resistance, Junction-Case	TO-220	$^{\circ}\text{C/W}$
$R_{\theta JA}$	Thermal Resistance, Junction-Air	TO-220	$^{\circ}\text{C/W}$
$T_{OPR}$	Operating Temperature Range	0 to +125	$^{\circ}\text{C}$
$T_{STG}$	Storage Temperature Range	-65 to +150	$^{\circ}\text{C}$

**Electrical Characteristics (KA79M05 / KA79M05R / LM79M05)**

Refer to test circuit,  $0^{\circ}\text{C} \leq T_J \leq +125^{\circ}\text{C}$ ,  $I_O = 350\text{ mA}$ ,  $V_I = -10\text{ V}$ ,  $C_I = 0.33\text{ }\mu\text{F}$ ,  $C_O = 0.1\text{ }\mu\text{F}$  unless otherwise specified.

Symbol	Parameter	Conditions	Min.	Typ.	Max.	Unit
$V_O$	Output Voltage	$T_J = +25^{\circ}\text{C}$	-4.80	-5.00	-5.20	V
		$I_O = 5\text{ mA to }350\text{ mA}$ , $V_I = -7\text{ V to }-25\text{ V}$	-4.75	-5.00	-5.25	
$\Delta V_O$	Line Regulation <sup>(2)</sup>	$T_J = +25^{\circ}\text{C}$	$V_I = -7\text{ V to }-25\text{ V}$	7	50	mV
			$V_I = -8\text{ V to }-25\text{ V}$	2	30	
$\Delta V_O$	Load Regulation <sup>(2)</sup>	$I_O = 5\text{ mA to }500\text{ mA}$ , $T_J = +25^{\circ}\text{C}$		30	100	mV
$I_Q$	Quiescent Current	$T_J = +25^{\circ}\text{C}$		3.0	6.0	mA
$\Delta I_Q$	Quiescent Current Change	$I_O = 5\text{ mA to }350\text{ mA}$			0.4	mA
		$I_O = 200\text{ mA}$ , $V_I = -8\text{ V to }-25\text{ V}$			0.4	
$\Delta V_O/\Delta T$	Output Voltage Drift	$I_O = 5\text{ mA}$		-0.2		mV/ $^{\circ}\text{C}$
$V_N$	Output Noise Voltage	$f = 10\text{ Hz to }100\text{ kHz}$ , $T_A = +25^{\circ}\text{C}$		40		$\mu\text{V}$
RR	Ripple Rejection	$f = 120\text{ Hz}$ , $V_J = -8\text{ V to }-18\text{ V}$	54	60		dB
$V_D$	Dropout Voltage	$T_J = +25^{\circ}\text{C}$ , $I_O = 500\text{ mA}$		1.1		V
$I_{SC}$	Short-Circuit Current	$T_J = +25^{\circ}\text{C}$ , $V_I = -35\text{ V}$		140		mA
$I_{PK}$	Peak Current	$T_J = +25^{\circ}\text{C}$		650		mA

**Note:**

2. Load and line regulation are specified at constant junction temperature. Change in  $V_O$  due to heating effects must be taken into account separately. Pulse testing with low duty is used.

**Electrical Characteristics (KA79M12R)**

Refer to test circuit,  $0^{\circ}\text{C} \leq T_J \leq +125^{\circ}\text{C}$ ,  $I_O = 350\text{ mA}$ ,  $V_I = -19\text{ V}$ ,  $C_I = 0.33\text{ }\mu\text{F}$ ,  $C_O = 0.1\text{ }\mu\text{F}$  unless otherwise specified.

Symbol	Parameter	Conditions	Min.	Typ.	Max.	Unit	
$V_O$	Output Voltage	$T_J = +25^{\circ}\text{C}$	-11.5	-12.0	-12.5	V	
		$I_O = 5\text{ mA to }350\text{ mA}$ , $V_I = -14.5\text{ V to }-30\text{ V}$	-11.4	-12.0	-12.6		
$\Delta V_O$	Line Regulation <sup>(3)</sup>	$T_J = +25^{\circ}\text{C}$	$V_I = -14.5\text{ V to }-30\text{ V}$	8.0	80	mV	
			$V_I = -15\text{ V to }-25\text{ V}$	3.0	50		
$\Delta V_O$	Load Regulation <sup>(3)</sup>	$T_J = +25^{\circ}\text{C}$	$I_O = 5.0\text{ mA to }500\text{ mA}$		30	240	mV
$I_Q$	Quiescent Current	$T_J = +25^{\circ}\text{C}$		3	6	mA	
$\Delta I_Q$	Quiescent Current Change	$I_O = 5\text{ mA to }350\text{ mA}$			0.4	mA	
		$V_I = -14.5\text{ V to }-30\text{ V}$			0.4		
$\Delta V_O/\Delta T$	Output Voltage Drift	$I_O = 5\text{ mA}$		-0.8		mV/ $^{\circ}\text{C}$	
$V_N$	Output Noise Voltage	$f = 10\text{ Hz to }100\text{ kHz}$ , $T_A = +25^{\circ}\text{C}$		75		$\mu\text{V}$	
RR	Ripple Rejection	$f = 120\text{ Hz}$ , $V_I = -15\text{ V to }-25\text{ V}$		54	60	dB	
$V_D$	Dropout Voltage	$I_O = 500\text{ mA}$ , $T_J = +25^{\circ}\text{C}$		1.1		V	
$I_{SC}$	Short Circuit Current	$V_I = -35\text{ V}$ , $T_J = +25^{\circ}\text{C}$		140		mA	
$I_{PK}$	Peak Current	$T_J = +25^{\circ}\text{C}$		650		mA	

**Note:**

3. Load and line regulation are specified at constant junction temperature. Change in  $V_O$  due to heating effects must be taken into account separately. Pulse testing with low duty is used.

Typical Performance Characteristics

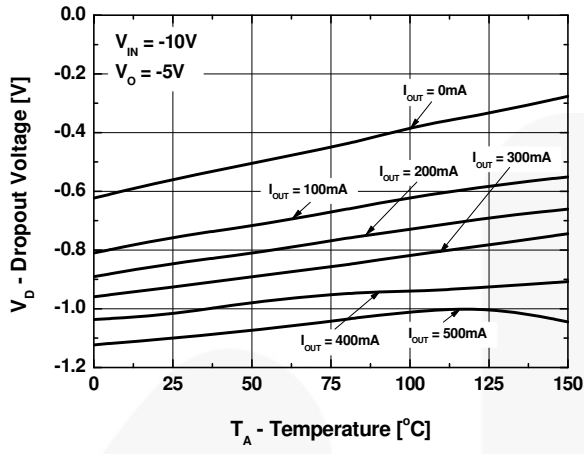

Figure 2. Dropout Voltage

## Typical Applications

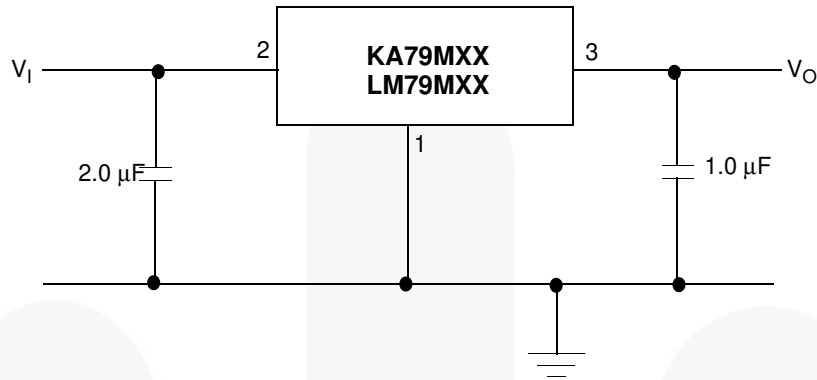

Figure 3. Fixed Output Regulator

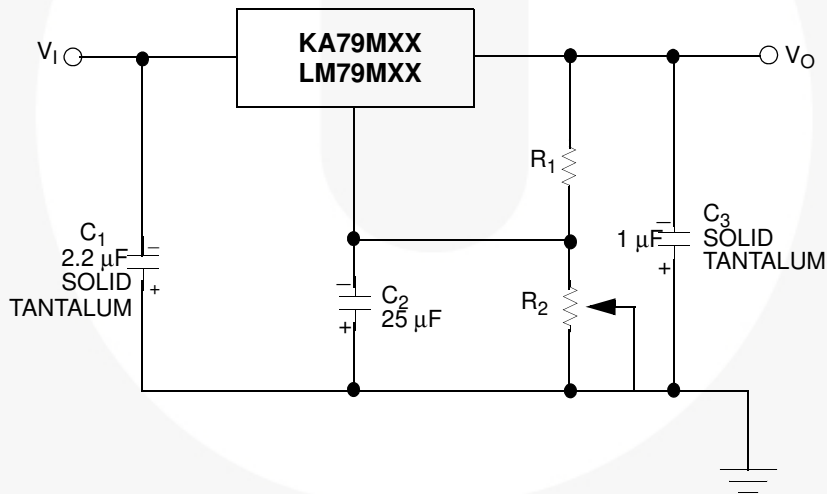

Figure 4. Variable Output

### Notes:

4. To specify an output voltage, substitute voltage value for "XX".
5.  $C_1$  is required if the regulator is located an appreciable distance from the power supply filter. For value given, capacitor must be solid tantalum. If aluminium electronics are used, 25  $\mu\text{F}$  aluminium electrolytic may be substituted.
6.  $C_2$  improves transient response and ripple rejection. Do not increase beyond 50  $\mu\text{F}$ .

Physical Dimensions

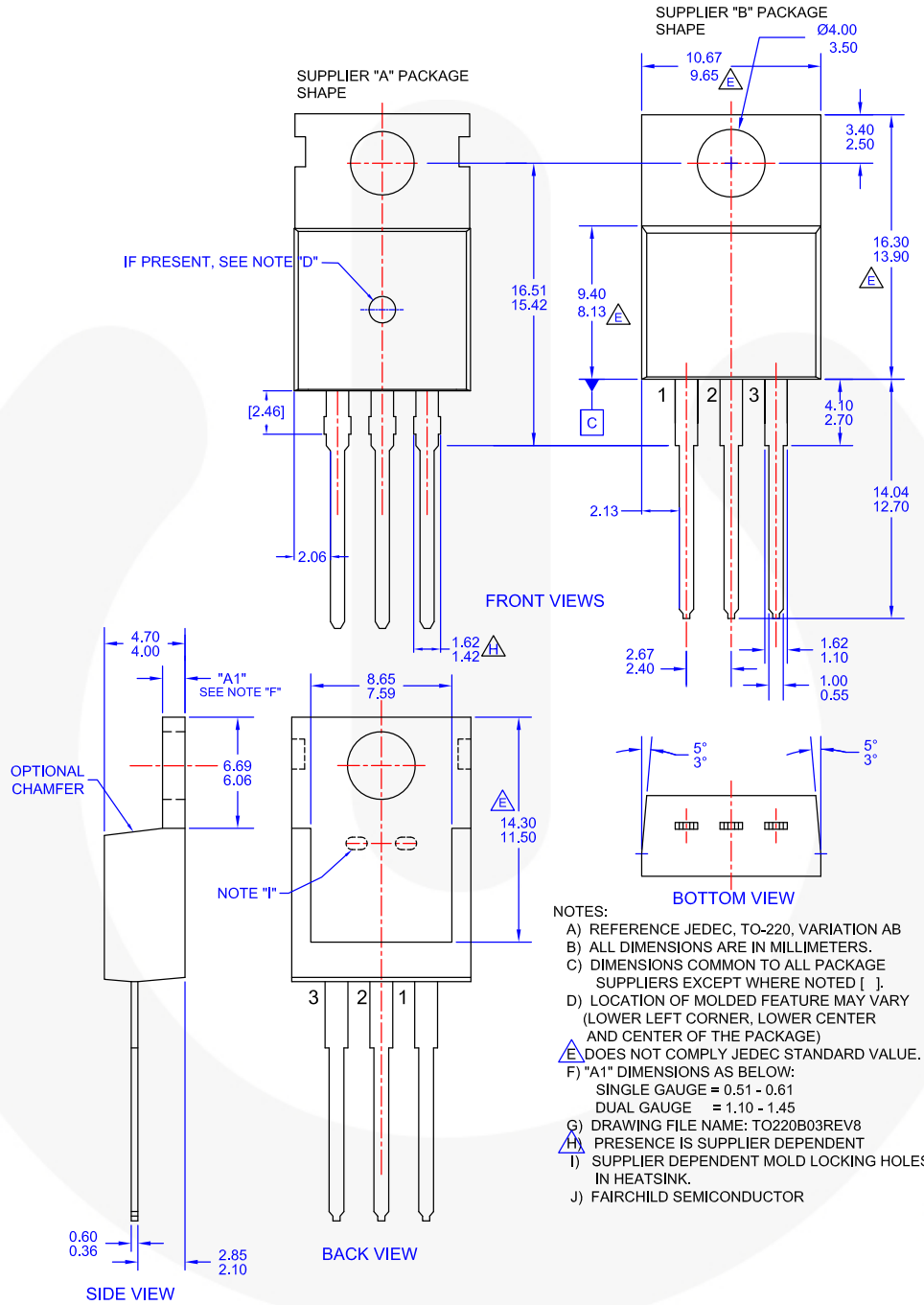
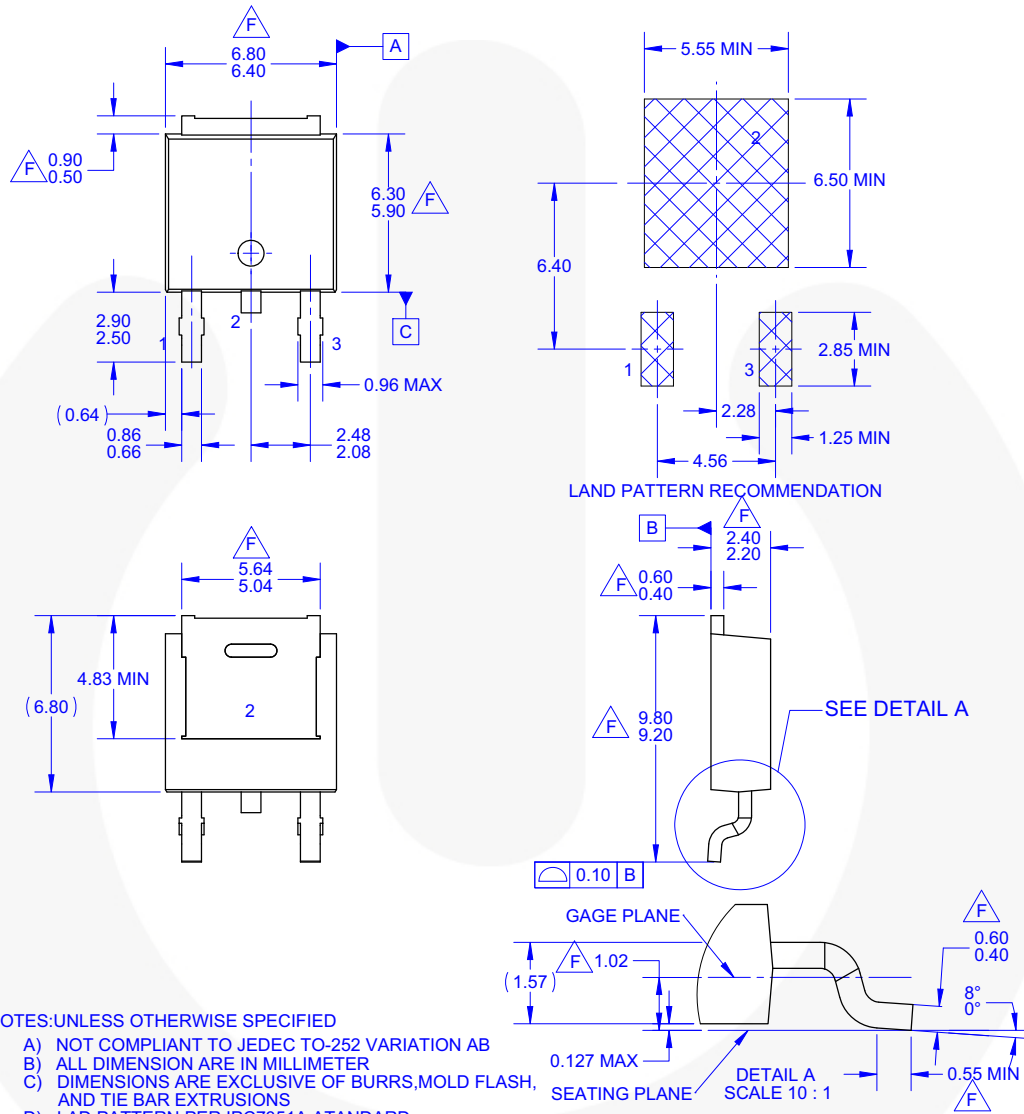

Figure 5. TO-220, MOLDED, 3LEAD, JEDEC VARIATION AB

Physical Dimensions (Continued)



NOTES: UNLESS OTHERWISE SPECIFIED

- A) NOT COMPLIANT TO JEDEC TO-252 VARIATION AB
- B) ALL DIMENSION ARE IN MILLIMETER
- C) DIMENSIONS ARE EXCLUSIVE OF BURRS, MOLD FLASH, AND TIE BAR EXTRUSIONS
- D) LAND PATTERN PER IPC7351A ATANDARD TO228P991X239-3N
- E) DRAWING FILE NAME: MKT-TO252D03REV3.
- F) DOES NOT COMPLY JEDEC STANDARD VALUE.
- G) FAIRCHILD SEMICONDUCTOR.

Figure 6. 3-LEAD, TO-252, JEDEC TO-252 VAR. AB, SURFACE MOUNT (DPAK)





### TRADEMARKS

The following includes registered and unregistered trademarks and service marks, owned by Fairchild Semiconductor and/or its global subsidiaries, and is not intended to be an exhaustive list of all such trademarks.

AccuPower™	F-PFS™		
Awinda®	FRFET®	PowerTrench®	TinyBoost®
AX-CAP®*	Global Power Resource™	PowerXS™	TinyBuck®
BitSiC™	GreenBridge™	Programmable Active Droop™	TinyCalc™
Build it Now™	Green FPS™	QFET®	TinyLogic®
CorePLUS™	Green FPS™ e-Series™	QS™	TINYOPTO™
CorePOWER™	Gmax™	Quiet Series™	TinyPower™
CROSSVOLT™	GTO™	RapidConfigure™	TinyPWM™
CTL™	IntelliMAX™		TinyWire™
Current Transfer Logic™	ISOPLANAR™	Saving our world, 1mW/W/kW at a time™	TranSiC™
DEUXPEED®	Making Small Speakers Sound Louder and Better™	SignalWise™	TriFault Detect™
Dual Cool™	MegaBuck™	SmartMax™	TRUECURRENT®*
EcoSPARK®	MICROCOUPLER™	SMART START™	µSerDes™
EfficientMax™	MicroFET™	Solutions for Your Success™	
ESBC™	MicroPak™	SPM®	UHC®
	MicroPak2™	STEALTH™	Ultra FRFET™
Fairchild®	MillerDrive™	SuperFET®	UniFET™
Fairchild Semiconductor®	MotionMax™	SuperSOT™-3	VCX™
FACT Quiet Series™	MotionGrid®	SuperSOT™-6	VisualMax™
FACT®	MTi®	SuperSOT™-8	VoltagePlus™
FAST®	MTx®	SupreMOS®	XS™
FastvCore™	MVN®	SyncFET™	Xsens™
FETBench™	mWSaver®	Sync-Lock™	仙童™
FPS™	OptoHiT™		

\* Trademarks of System General Corporation, used under license by Fairchild Semiconductor.

### DISCLAIMER

FAIRCHILD SEMICONDUCTOR RESERVES THE RIGHT TO MAKE CHANGES WITHOUT FURTHER NOTICE TO ANY PRODUCTS HEREIN TO IMPROVE RELIABILITY, FUNCTION, OR DESIGN. TO OBTAIN THE LATEST, MOST UP-TO-DATE DATASHEET AND PRODUCT INFORMATION, VISIT OUR WEBSITE AT [HTTP://WWW.FAIRCHILDSEMI.COM](http://www.fairchildsemi.com). FAIRCHILD DOES NOT ASSUME ANY LIABILITY ARISING OUT OF THE APPLICATION OR USE OF ANY PRODUCT OR CIRCUIT DESCRIBED HEREIN; NEITHER DOES IT CONVEY ANY LICENSE UNDER ITS PATENT RIGHTS, NOR THE RIGHTS OF OTHERS. THESE SPECIFICATIONS DO NOT EXPAND THE TERMS OF FAIRCHILD'S WORLDWIDE TERMS AND CONDITIONS, SPECIFICALLY THE WARRANTY THEREIN, WHICH COVERS THESE PRODUCTS.

### LIFE SUPPORT POLICY

FAIRCHILD'S PRODUCTS ARE NOT AUTHORIZED FOR USE AS CRITICAL COMPONENTS IN LIFE SUPPORT DEVICES OR SYSTEMS WITHOUT THE EXPRESS WRITTEN APPROVAL OF FAIRCHILD SEMICONDUCTOR CORPORATION.

As used herein:

1. Life support devices or systems are devices or systems which, (a) are intended for surgical implant into the body or (b) support or sustain life, and (c) whose failure to perform when properly used in accordance with instructions for use provided in the labeling, can be reasonably expected to result in a significant injury of the user.
2. A critical component in any component of a life support, device, or system whose failure to perform can be reasonably expected to cause the failure of the life support device or system, or to affect its safety or effectiveness.

### ANTI-COUNTERFEITING POLICY

Fairchild Semiconductor Corporation's Anti-Counterfeiting Policy. Fairchild's Anti-Counterfeiting Policy is also stated on our external website, [www.fairchildsemi.com](http://www.fairchildsemi.com), under Sales Support.

Counterfeiting of semiconductor parts is a growing problem in the industry. All manufacturers of semiconductor products are experiencing counterfeiting of their parts. Customers who inadvertently purchase counterfeit parts experience many problems such as loss of brand reputation, substandard performance, failed applications, and increased cost of production and manufacturing delays. Fairchild is taking strong measures to protect ourselves and our customers from the proliferation of counterfeit parts. Fairchild strongly encourages customers to purchase Fairchild parts either directly from Fairchild or from Authorized Fairchild Distributors who are listed by country on our web page cited above. Products customers buy either from Fairchild directly or from Authorized Fairchild Distributors are genuine parts, have full traceability, meet Fairchild's quality standards for handling and storage and provide access to Fairchild's full range of up-to-date technical and product information. Fairchild and our Authorized Distributors will stand behind all warranties and will appropriately address any warranty issues that may arise. Fairchild will not provide any warranty coverage or other assistance for parts bought from Unauthorized Sources. Fairchild is committed to combat this global problem and encourage our customers to do their part in stopping this practice by buying direct or from authorized distributors.

### PRODUCT STATUS DEFINITIONS

#### Definition of Terms

Datasheet Identification	Product Status	Definition
Advance Information	Formative / In Design	Datasheet contains the design specifications for product development. Specifications may change in any manner without notice.
Preliminary	First Production	Datasheet contains preliminary data; supplementary data will be published at a later date. Fairchild Semiconductor reserves the right to make changes at any time without notice to improve design.
No Identification Needed	Full Production	Datasheet contains final specifications. Fairchild Semiconductor reserves the right to make changes at any time without notice to improve the design.
Obsolete	Not In Production	Datasheet contains specifications on a product that is discontinued by Fairchild Semiconductor. The datasheet is for reference information only.