

THIS DRAWING IS UNPUBLISHED.  
 VERTRAULICHE UNVERÖFFENTLICHTE ZEICHNUNG  
 © COPYRIGHT 2011 Tyco Electronics AMP GmbH

RELEASED FOR PUBLICATION  
 FREI FUER VERÖFFENTLICHUNG  
 2011- ALL RIGHTS RESERVED.  
 ALLE RECHTE VORBEHALTEN.

MATED WITH:  
 PASSEND ZU:

LOC	DIST	REVISIONS					
A1	-	P	LTR	DESCRIPTION	DATE	DWN	APVD
PROJEKT NR.:		A1		NEW DRAWING	22MAY2012	SG	ODC
		A2		ECR-12-01316	21JUN2012	JJ	ODC
		A3		ECR-12-013990	21AUG2012	SG	ODC
		B		ECR-15-002893	26FEB2015	SG	ODC

Bemerkungen  
 NOTES

- 1 Massgebend ist der deutsche Text  
 ONLY THE GERMAN LANGUAGE VERSION SHALL BE BINDING
- 2 Einzelheiten der Ausfuehrung bleiben dem Hersteller ueberlassen  
 DETAILS OF DESIGN ARE LEFT TO MANUFACTURER

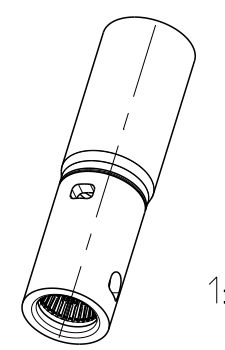
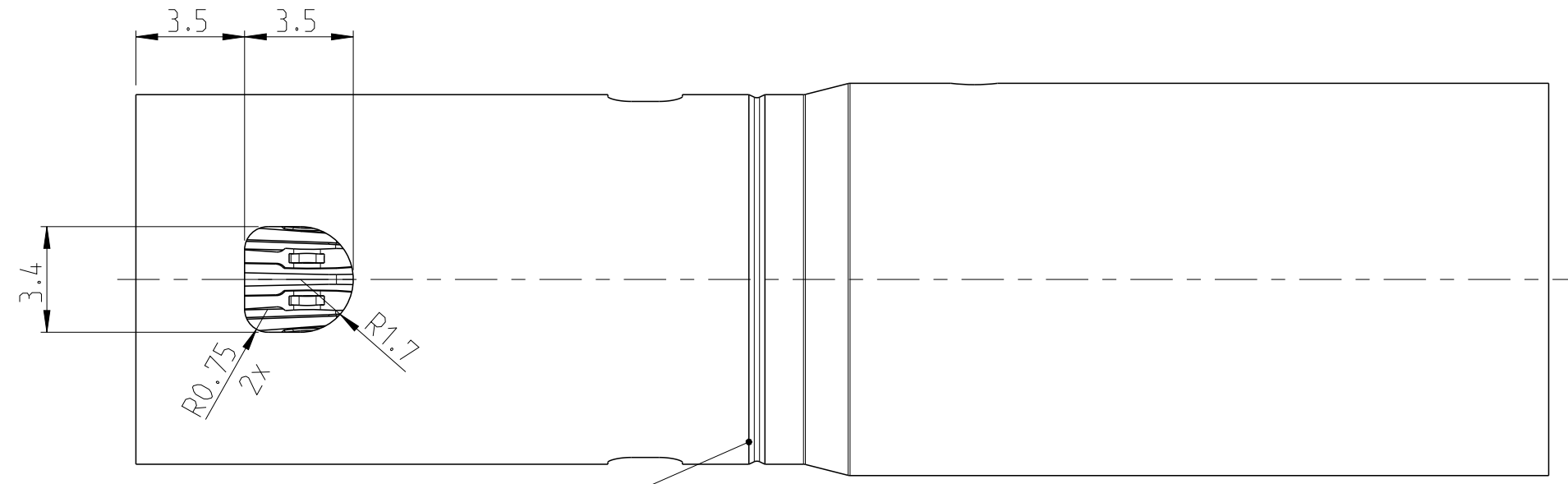
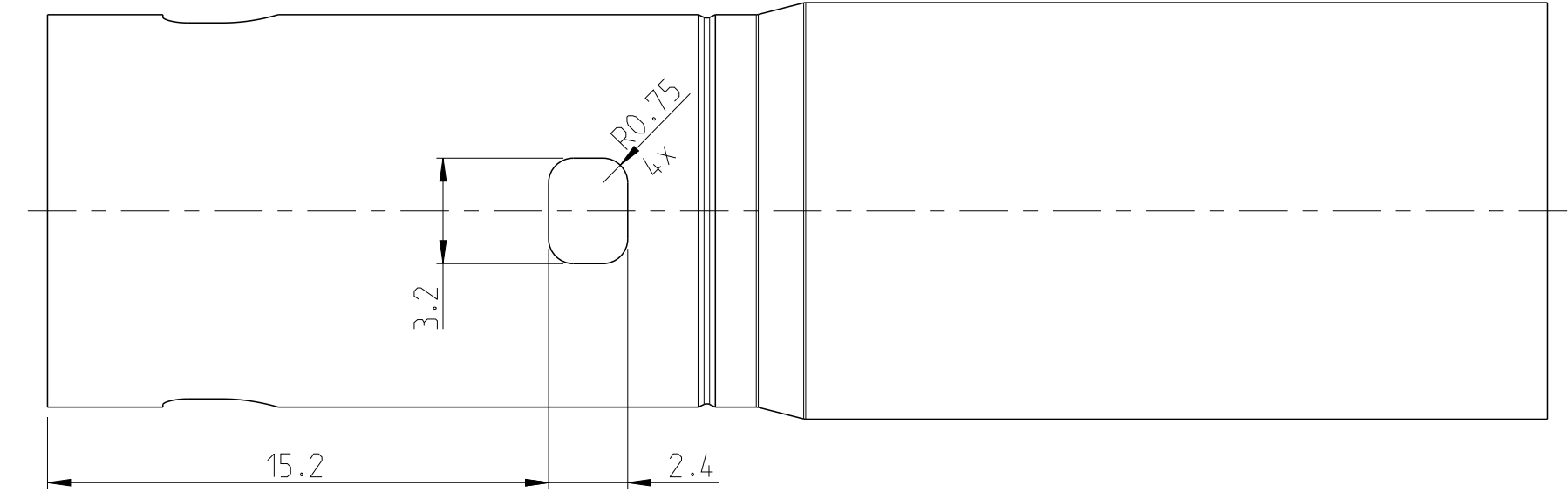
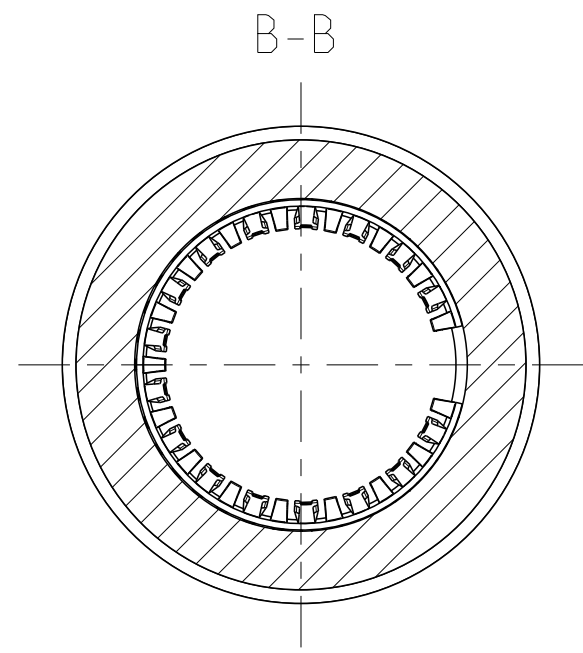
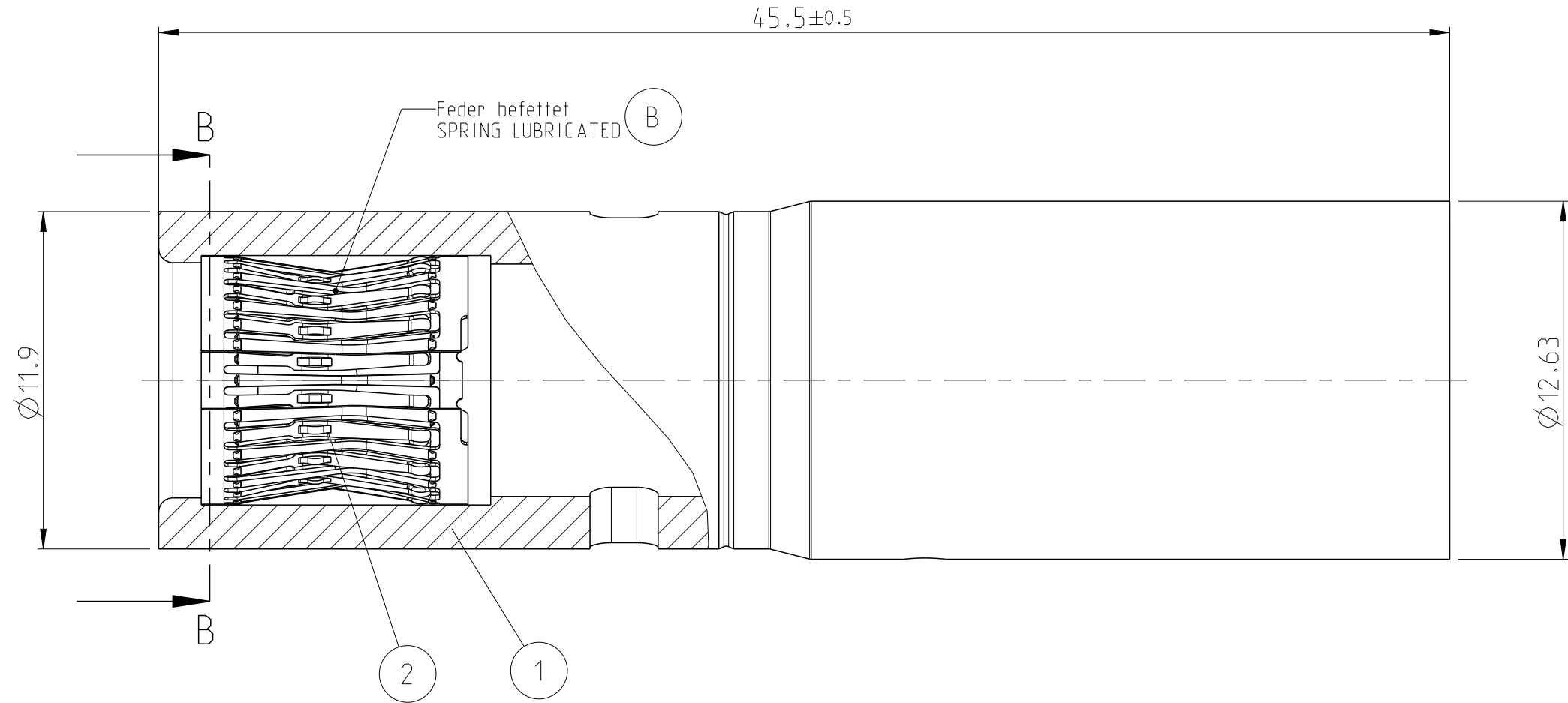

1:1

Markierungsnut fuer CuTe  
 MARKING GROOVE FOR CuTe

2177590-1	B	2	Feder/SPRING	1	Ag	CuNiSi
TE BESTELL-NR. ORDER NO.	REV.	ITEM	Benennung DESCRIPTION	QTY	obere Beschichtung UPPER SURFACE	Material
		1	Buchse/SOCKET	1	Ag	Cu Te

THIS DRAWING IS A CONTROLLED DOCUMENT.  
 DIESE ZEICHNUNG IST EIN KONTROLLIERTES DOKUMENT.

DIMENSIONS:  
 MASSEINHEITEN:  
 (MM)

TOLERANCES UNLESS  
 OTHERWISE SPECIFIED:  
 ALLGEMEINTOLERANZEN

0 PLC ±0.2  
 1 PLC ±0.1  
 2 PLC ±0.1  
 3 PLC ±  
 4 PLC ±  
 ANGLES/WINKEL °  
 FINISH/OBERFLAECHE/FARBE

MATERIAL

TOLERANCING ISO 8015 TOLERIERUNG ISO 8015		DWN	S. G.	26SEP2011	TE Connectivity
APVD		CHK	O. De Cloet	26SEP2011	
PRODUCT SPEC		APVD	V. Seipel	26SEP2011	
APPLICATION SPEC		NAME	HV 8mm		
VERARBEITUNGSSPEZ.		PRODUCT SPEC	108-94255		Buchsenkontakt 180 Grad, 35qmm, Zusammenbau SOCKET CONTACT 180 DEG., 35sqmm, Assembly
WEIGHT		SIZE	CAGE CODE	DRAWING NO	RESTRICTED TO
GEWICHT		A2	00779	C-2177590	NUR FUER
CUSTOMER DRAWING		/SONDERZEICHNUNG		SCALE	1:1
				SHEET	1 OF 1
				BLATT	VON 1
				REV	B