

AEDA-3200-Txx Series

Ultra Miniature, High Resolution Incremental Encoders

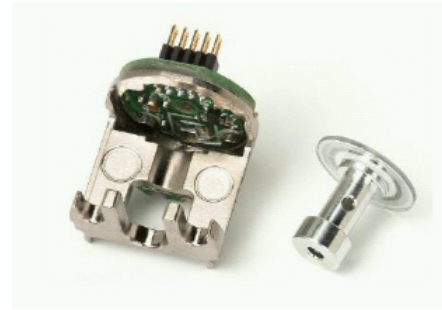

Data Sheet



Description

The AEDA-3200-T series (top mounting type) are high performance, cost effective, three-channel optical incremental encoder modules.

AEDA-3200-T series emphasize high reliability, high resolution and easy assembly, using transmissive encoder technology to sense rotary position. Outputs of the AEDA-3200 encoders are two channel quadrature outputs and a third channel gated index output. These encoder modules can be easily mounted to customer specific applications with the specially designed mechanical alignment tool.

Features

- Two channel quadrature output with index
- Quick and easy assembly with alignment tool
- Cost-effective
- Ultra miniature size ($\phi 17$ mm)
- Resolution options from 2500 to 7500 Cycles Per Revolution (CPR), up to 30000 counts with 4X decoding
- Integrated RS 422 differential line driver

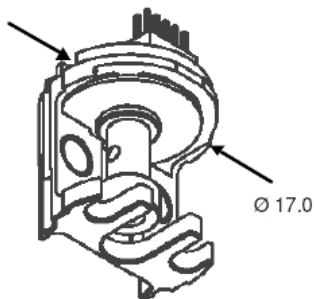
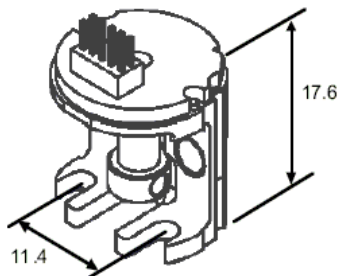

Outline Drawing

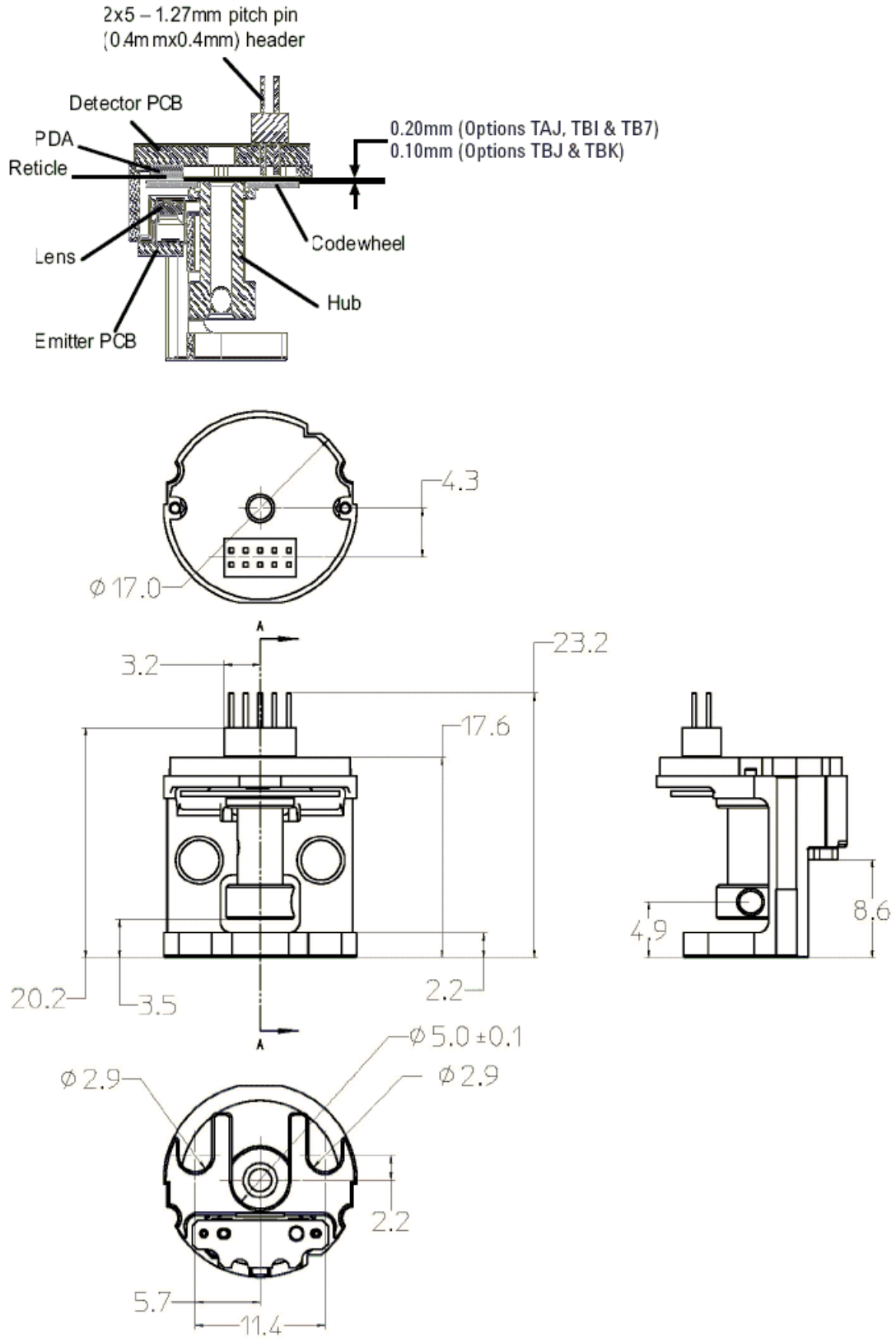

Theory of Operation

The AEDA-3200 translates rotary motion of a shaft into a three channel digital output. The AEDA-3200 series has five key parts: a single light emitting diode (LED) light source, a photodetector IC with a set of uniquely configured photodiodes, an interpolator IC, a line driver IC and a pair of lenses.

This light is used to produce internal signals A and A⁻; and B and B⁻:

As part of the “push-pull” detector system, these signals are fed through comparators and line driver that are part of the signal processing circuitry to produce the final outputs for channels A.

The AEDA-3200 is available for cycles per revolution (CPR) of 2500 to 7500. This translates to a maximum resolution of 30000 counts after quadrature decode (4X).

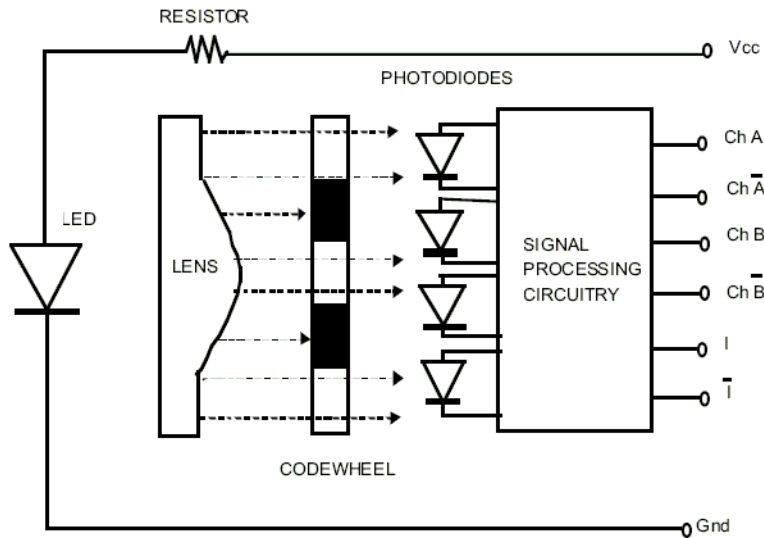

Output Waveforms

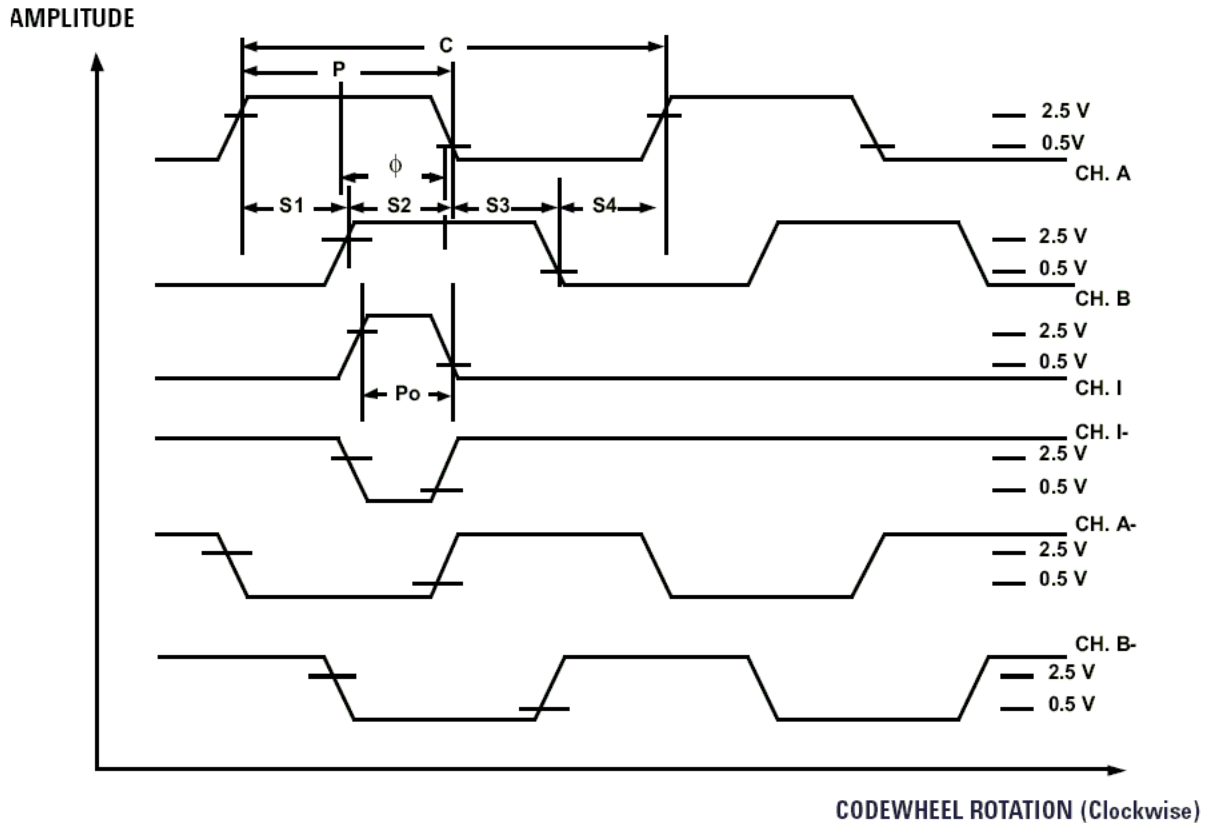

Definitions

Count (N): N refers to the cycles per revolution (CPR) of the encoder output.

One Cycle (C): 360 electrical degrees (°e).

One Shaft Rotation: 360 mechanical degrees, N cycles (rotary motion only).

Phase (ϕ): The number of electrical degrees between the center of the high state on the channel A and the center of the high state of channel B. This value is nominally 90°e.

Pulse Width (P): The number of the electrical degrees that an output is a high-level during one cycle, nominally 180°e or 1/2 a cycle.

Pulse Width Error (ΔP): The deviation in electrical degrees of the pulse width from its ideal value of 180°e.

Index Pulse Width (Po): The number of electrical degrees that an index is high during one full shaft rotation. This value is nominally 90°e or 1/4 cycle.

State Width (S): The number of the electrical degrees between a transition in the output of the channel B. There are 4 states per cycle, each nominally 90°e.

State Width Error (ΔS): The deviation in electrical degrees of each state width from its ideal value of 90°e.

Direction of Motor Rotation

When the codewheel rotates in a clockwise direction, channel A will lead channel B (Figure 1 illustrates the definition of clockwise direction of codewheel rotation). When the codewheel rotates in a counter-clockwise direction, channel B will lead channel A.

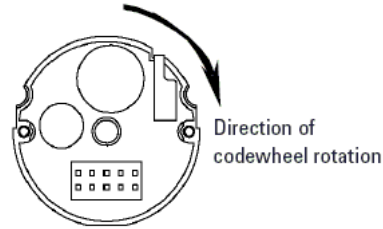

Figure 1. Viewed from the PCB encoder end.

Absolute Maximum Ratings

Storage Temperature	-40°C to 125°C
Operating Temperature	-40°C to 125°C
Supply Voltage	4.5 V to 5.5 V
Output Voltage	-0.5 V to V_{cc}
Output Current per Channel	20 mA
Frequency	750 kHz

Recommended Operating Conditions

Parameter	Symbol	Min.	Typical	Max.	Units	Notes
Temperature	T_A	-40	25	125	°C	
Supply Voltage	V_{cc}	4.5	5.0	5.5	Volts	Ripple < 100 mVp-p
Frequency	f		125	750	kHz	$f = \frac{RPM \times CPR}{60}$

Maximum Frequency and RPM

CPR	Maximum Frequency (kHz)	Maximum RPM ²
2500	750 ¹	12000
5000	750	9000
6000	750	7500
7200	750	6250
7500	750	6000

Note:

1. Maximum frequency will be lower due to limitation in maximum RPM.
2. Maximum mechanical limit is 12000 RPM, operating limit is dependent on the maximum operating frequency.

Electrical Characteristics

Electrical characteristics over recommended operating conditions. Typical values at 25°C.

Parameter	Symbol	Min.	Typical	Max.	Units
Supply Current	I_{CC}		55	80	mA
High level Output Voltage	V_{OH}	2.5	3.4		V
Low level Output Voltage	V_{OL}		0.3	0.5	V

Encoding Characteristics

Encoding characteristics over recommended operating conditions. Typical values at 25°C.

Parameter	Symbol	Typical	Max.	Units
Pulse Width Error	ΔP	5	85	°e
State Width Error	ΔS	5	60	°e
Phase Error	$\Delta\phi$	1	40	°e

Mechanical Characteristics

(Refer to page 2 for details.)

Parameter	Dimension/Details	Tolerance	Units
Standard Shaft Diameters	2 mm diameter maximum *	-.002/-0.007 (-.0001/-0.0003)	mm (in)
Mounting Screw Size:	M2.5 x 0.45 (Recommended Length 6 mm)		mm

* Note:

- Using a step shaft, maximum shaft diameter is 4 mm.

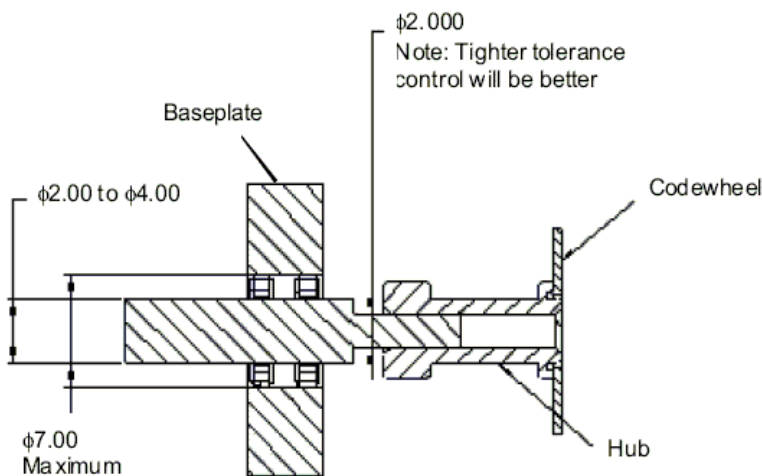

Pin Assignments

Pin	Signal	Description
Pin 1	A+	Digital Output
Pin 2	A-	Digital Output
Pin 3	Gnd	Ground Pin
Pin 4	Gnd	Ground Pin
Pin 5	B+	Digital Output
Pin 6	B-	Digital Output
Pin 7	Vcc	Input Voltage
Pin 8	Vcc	Input Voltage
Pin 9	I+	Digital Output
Pin 10	I-	Digital Output

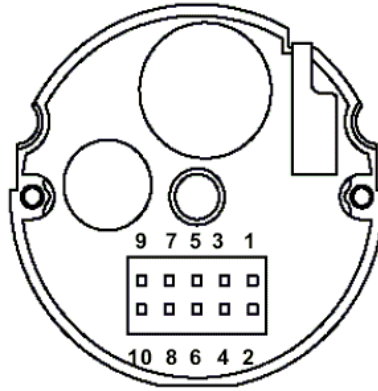

Notes:

1. Both Pin 7 and Pin 8 must be connected to Vcc.
2. Either Pin 3 or Pin 4 must be connected to Gnd.

Mating Connector

AEDA-3200 requires a 5 x 2 (1.27 mm x 1.27 mm) female IDC Connector. An example of the suggested mating connectors is Samtec (www.samtec.com) part number: FFSD-05-D-x-01-N. The cable used is 0.635 mm pitch flat ribbon cable.

Electrical Interface

Avago recommends National Semiconductor DS26C32AM Quad Differential Line Receiver or compatible as line receiver. Unused pin should be grounded for noise reduction.

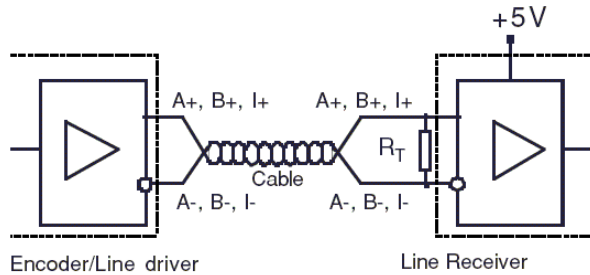

Alignment Considerations

The mechanical alignment tool is intended to absorb normal installation misalignment and runouts. To achieve the optimum performance, user should minimize misalignment.

Complete instructions for AEDA-3200 installation can be found in Application Note 5080, Avago AEDA-3200-T Mechanical Mounting and Installation Consideration. AEDA-3200 Mechanical Alignment tool part number is HEDS-8940.

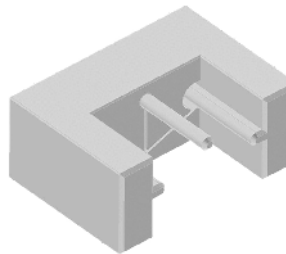

HEDS-8940 Mechanical Alignment Tool.

Ordering Information

AEDA-3200-T

	Resolution Options (CPR)	Counts After 4x Decoding
A J	2,500	10,000
B 1	5,000	20,000
B 7	6,000	24,000
B J	7,200	28,800
B K	7,500	30,000

Alignment Tool	Remark
HEDS-8940	Mechanical Alignment Tool

For product information and a complete list of distributors, please go to our web site: www.avagotech.com

Avago, Avago Technologies, and the A logo are trademarks of Avago Technologies, Limited in the United States and other countries.
Data subject to change. Copyright © 2006 Avago Technologies, Limited. All rights reserved. Obsoletes AV01-0175EN
AV01-0619EN - November 1, 2006

AVAGO
TECHNOLOGIES