

LOC	DIST	REVISIONS			
P	LTN	DESCRIPTION	DATE	DWN	APVD
GP	00				
A		REVISED PER ECO-15-002647	05MAR2015	AP	MS
B		REVISED PER ECO-16-014593	14FEB2017	JW	SH

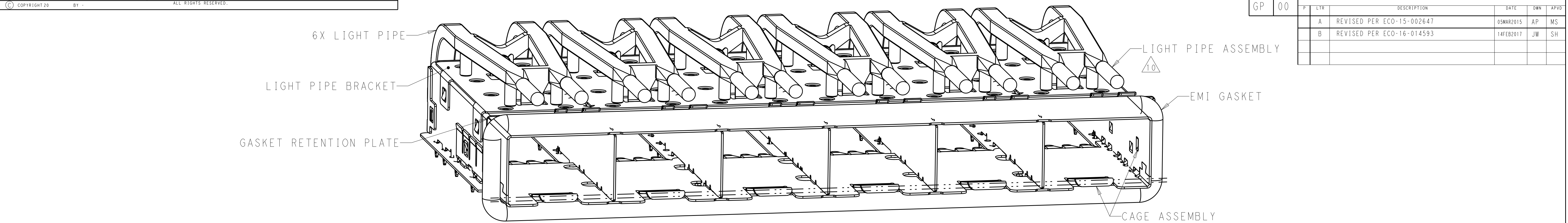

2198723-1  
SCALE 4:1

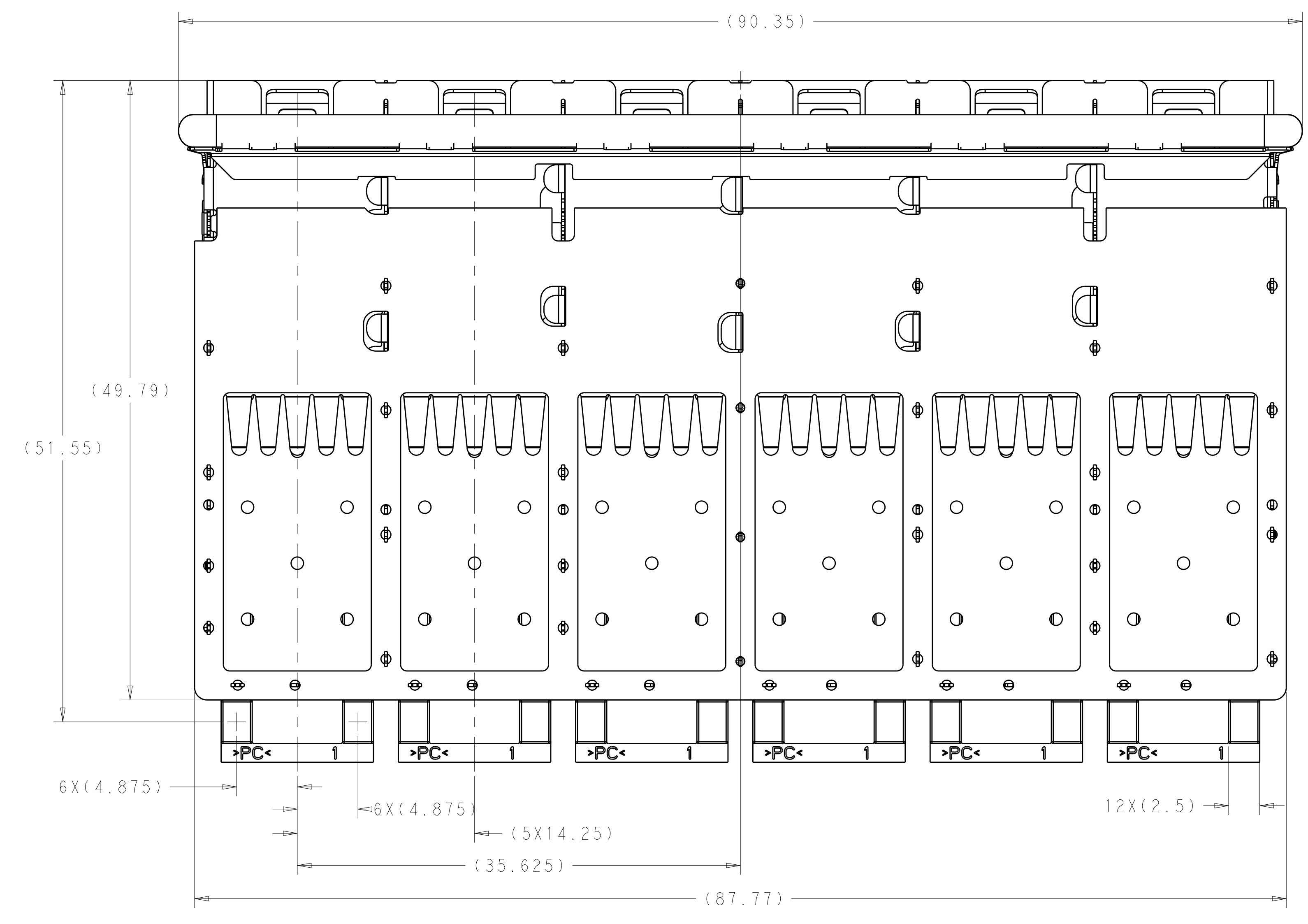
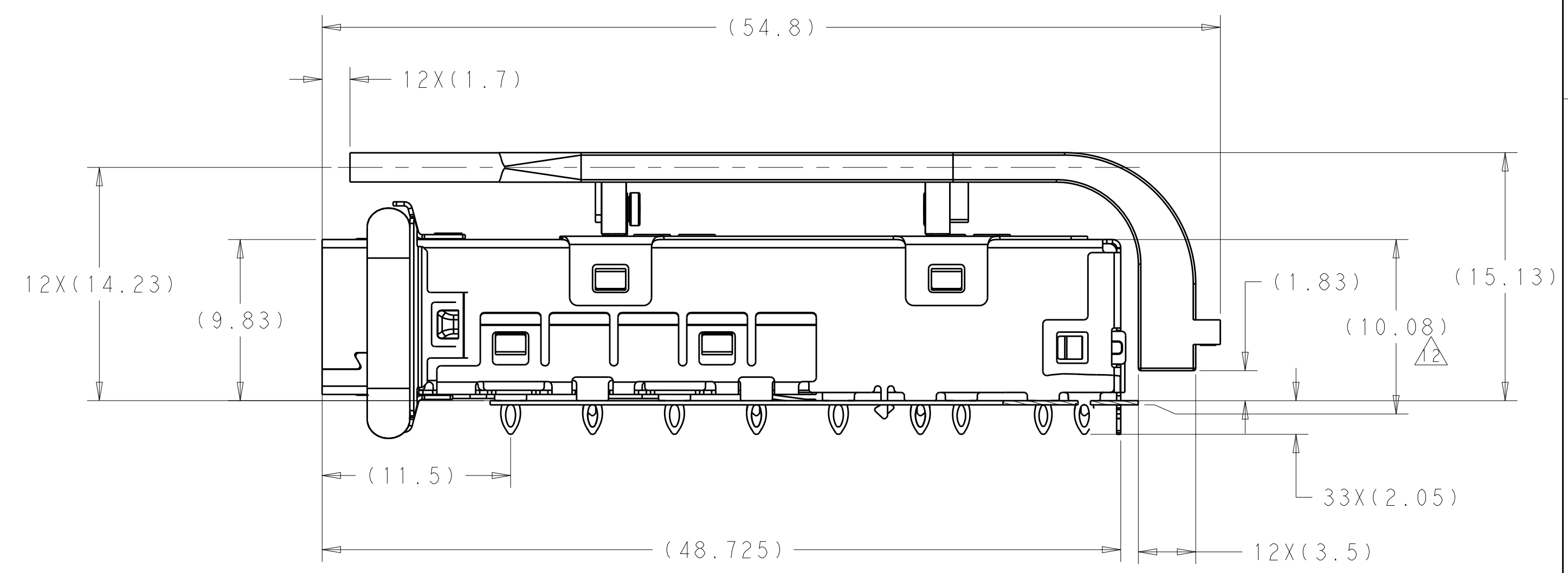
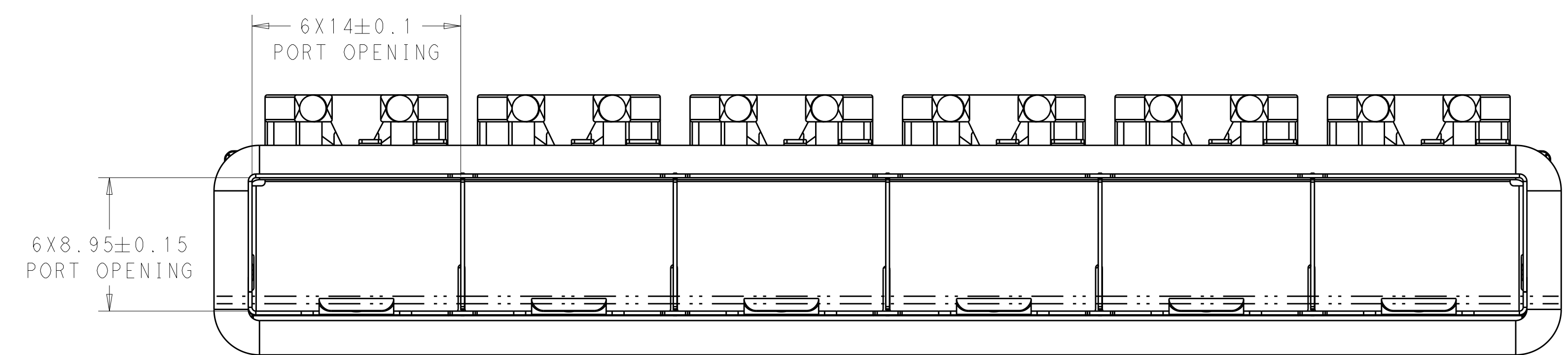

- △ MATERIAL:  
CAGE ASSEMBLY: NICKEL SILVER ALLOY, (0.25mm)  
GASKET RETENTION PLATE: STAINLESS STEEL  
EMI GASKET: PLATED FILLED SILICONE  
PCB GASKET: RF ABSORBER  
LIGHT PIPE BRACKET: STAINLESS STEEL  
LIGHT PIPE: POLYCARBONATE, CLEAR
- △ MINIMUM PC BOARD THICKNESS:  
SINGLE SIDED = 1.45mm  
BELLY TO BELLY = 3mm
- △ PADS AND VIAS CHASSIS GROUND
- △ DATUM AND BASIC DIMENSION ESTABLISHED BY CUSTOMER
- 5. MATES WITH SFP MSA COMPLIANT TRANSCEIVERS
- 6. INTERPRETATION OF DATUM REFERENCE FRAME IN ACCORDANCE WITH SECT 4.4.1.1 OF ASME Y14.5M-1994
- △ REFERENCE APPLICATION SPEC. 114-13120, HOLE A, FOR RECOMMENDED DRILL HOLE DIAMETER AND PLATING THICKNESS
- △ REFERENCE APPLICATION SPEC. 114-13120, HOLE B, FOR RECOMMENDED DRILL HOLE DIAMETER AND PLATING THICKNESS
- △ HOLE PATTERN REPEATS FOR EACH PORT, SPACING BETWEEN PORTS IS 14.25mm
- △ LIGHT PIPE ASSEMBLY SHIPPED UNASSEMBLED TO CAGE ASSEMBLY, CAGE ASSEMBLY TO BE PRESSED INTO THE PCB PRIOR TO ATTACHING LIGHT PIPE ASSEMBLY TO CAGE
- 11. PRODUCT COMPLIES WITH SPECIFICATION SFF-8433, IMPROVED PLUGGABLE FORM FACTOR FOR SFP+ GANGED CAGES
- △ CONTACT STANDOFF WILL PIERCE GASKET WHEN PROPERLY PRESSED INTO PCB.

2198723-1  
PART NUMBER

THIS DRAWING IS A CONTROLLED DOCUMENT.		DWN: M.E. CONNER 24JAN2013	TE Connectivity
DIMENSIONS: mm		CHK: M.D. MORRISON 01FEB2013	
TOLERANCES UNLESS OTHERWISE SPECIFIED:		APVD: M.J. PHILLIPS 01FEB2013	NAME: CAGE ASSEMBLY WITH LIGHT PIPES, ENHANCED, PRESS-FIT, 1X6, zSFP+ PRODUCT SPEC: - APPLICATION SPEC: -
0 PLC ±0.25 1 PLC ±0.25 2 PLC ±0.25 3 PLC ±0.25 4 PLC ±0.25 ANGLES ±°		SIZE: A1 CAGE CODE: 00779 DRAWING NO: 2198723	
MATERIAL: SEE NOTES		FINISH: SEE NOTES	RESTRICTED TO: -
Customer Drawing		SCALE: 4:1	SHEET 1 OF 4 REV B

LOC	DIST	REV	DATE	BY	APPV
GP	00				

REVISIONS		DATE	BY	APPV
1	SEE SHEET 1			

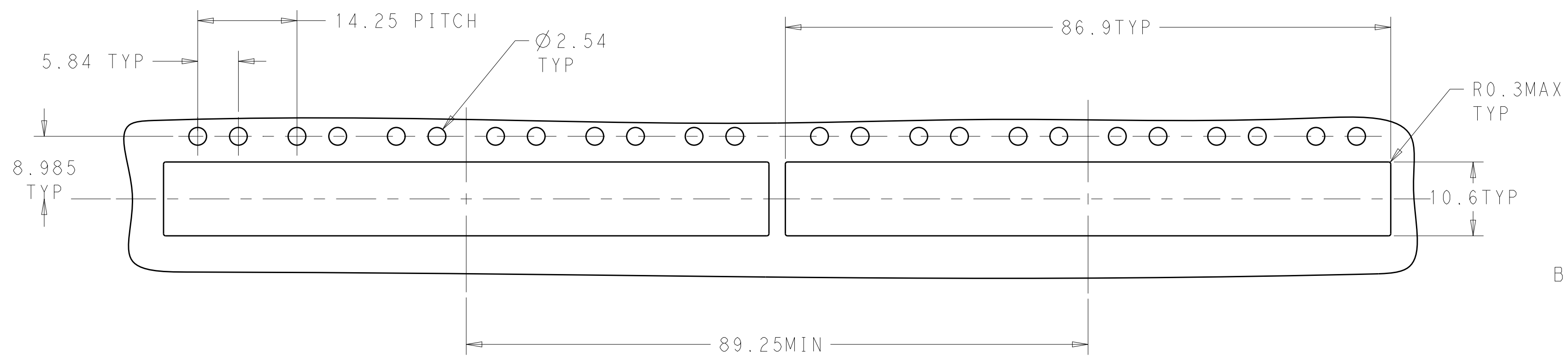

RECOMMENDED BEZEL OPENING  
 SINGLE SIDED APPLICATIONS  
 SCALE 2:1

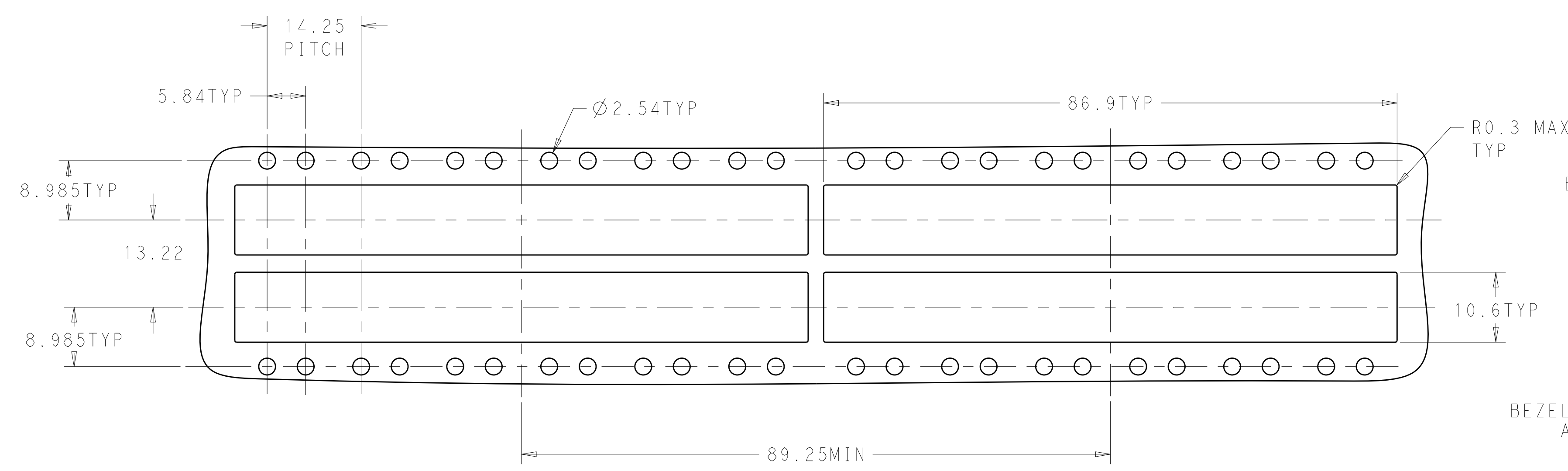
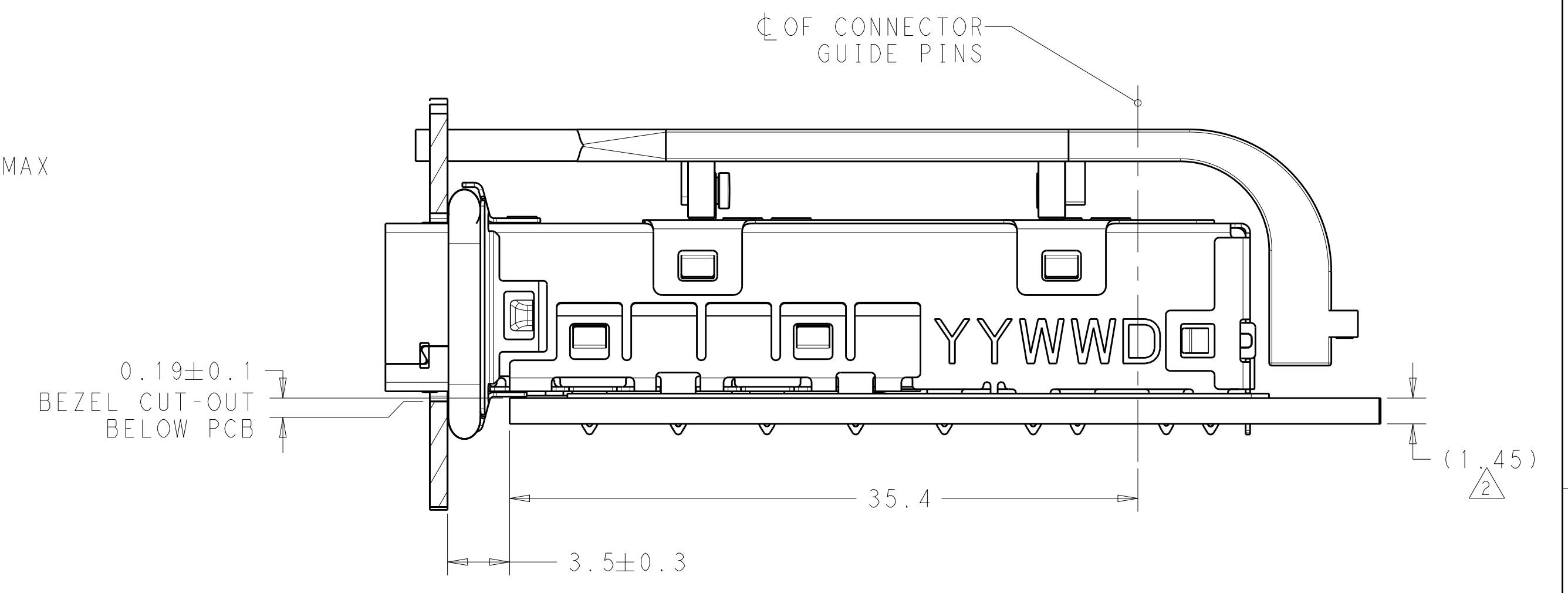

RECOMMENDED BEZEL OPENING  
 BELLY TO BELLY APPLICATIONS  
 SCALE 2:1

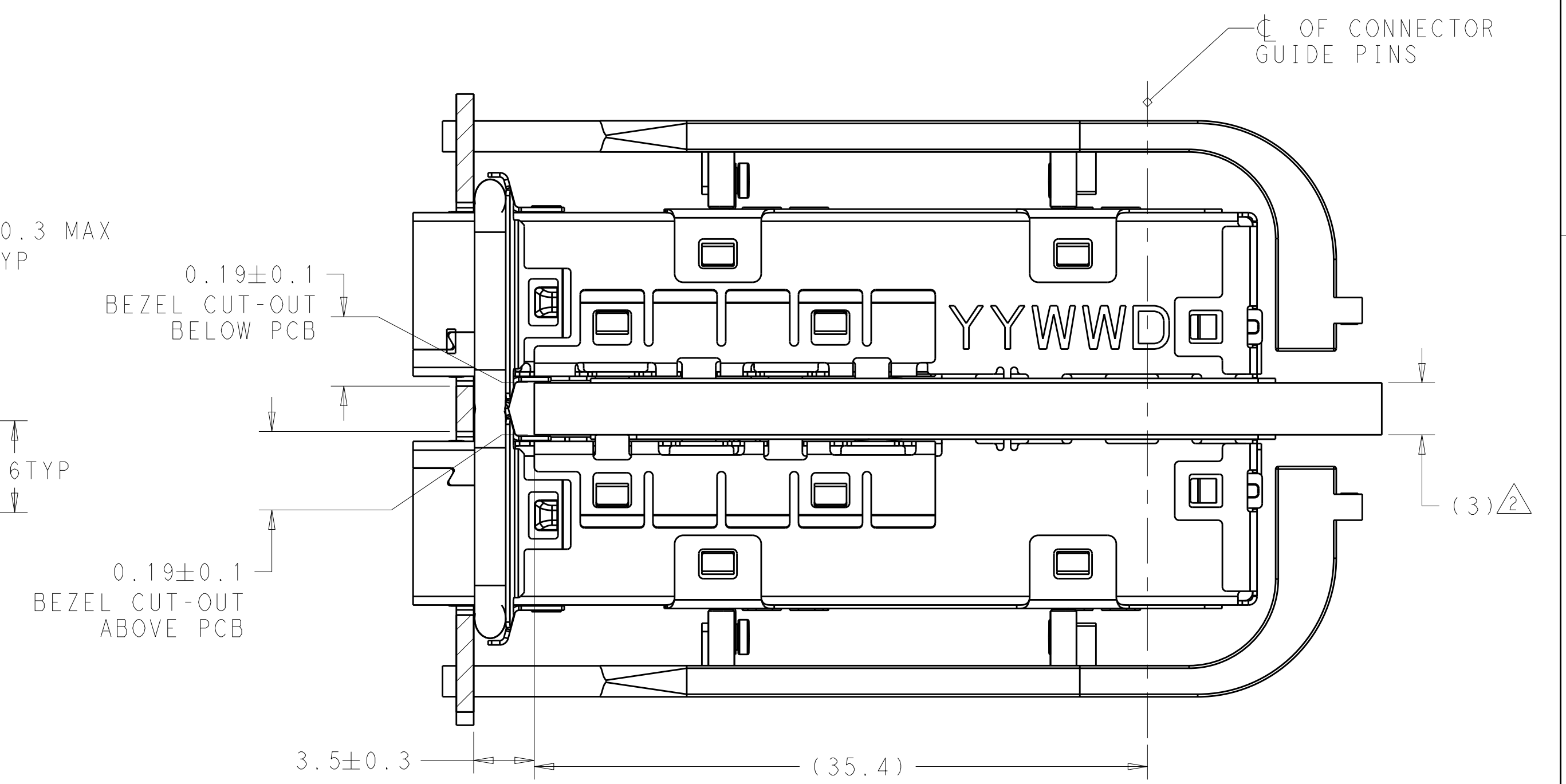

MOUNTED BELLY TO BELLY ON PC BOARD  
 SHOWN THRU RECOMMENDED BEZEL  
 SCALE 4:1

THIS DRAWING IS A CONTROLLED DOCUMENT.		OWN: M.E. CONNER 24 JAN 2013	TE Connectivity CAGE ASSEMBLY WITH LIGHT PIPES, ENHANCED, PRESS-FIT, 1X6, zSFP+
DIMENSIONS: mm		CHK: M.D. MORRISON 01 FEB 2013	
TOLERANCES UNLESS OTHERWISE SPECIFIED:		APVD: M.J. PHILLIPS 01 FEB 2013	NAME: PRODUCT SPEC
0 PLC ±0.1	1 PLC ±0.1	2 PLC ±0.1	3 PLC ±0.1
4 PLC ±0.2	ANGLES ±°	FINISH ±μm	APPLICATION SPEC
MATERIAL: SEE NOTES	FINISH: SEE NOTES	WEIGHT: -	SIZE: A100779
Customer Drawing		SCALE: 4:1	SHEET 2 OF 4

LOC	DIST	REV	DATE	BY	APPV
GP	00				
REV		LTN	DESCRIPTION	DATE	BY
			SEE SHEET 1		

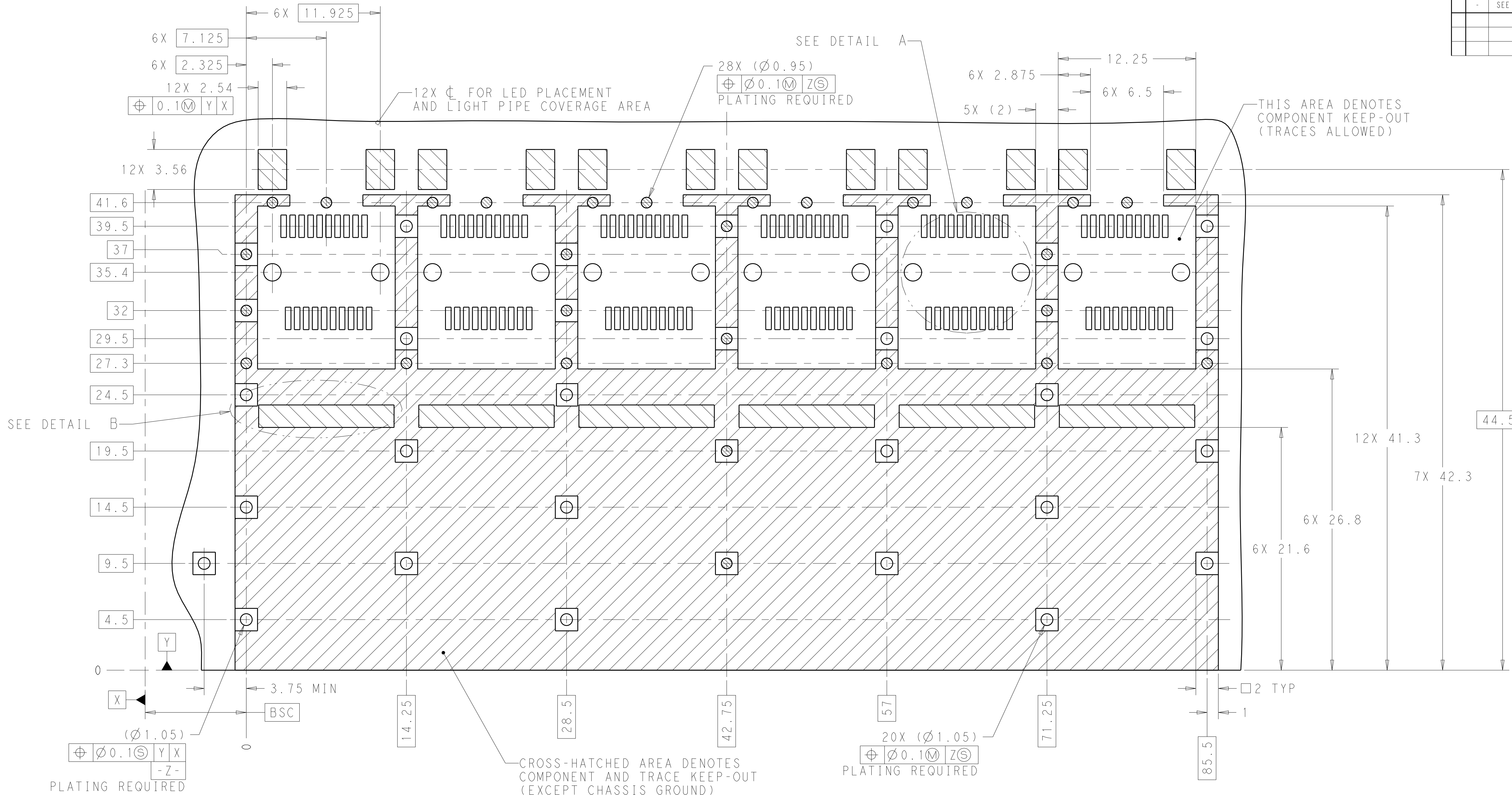

RECOMMENDED PCB CONFIGURATION  
 WITH KEEP-OUT AREAS FOR SINGLE SIDED APPLICATION  
 SCALE 5:1

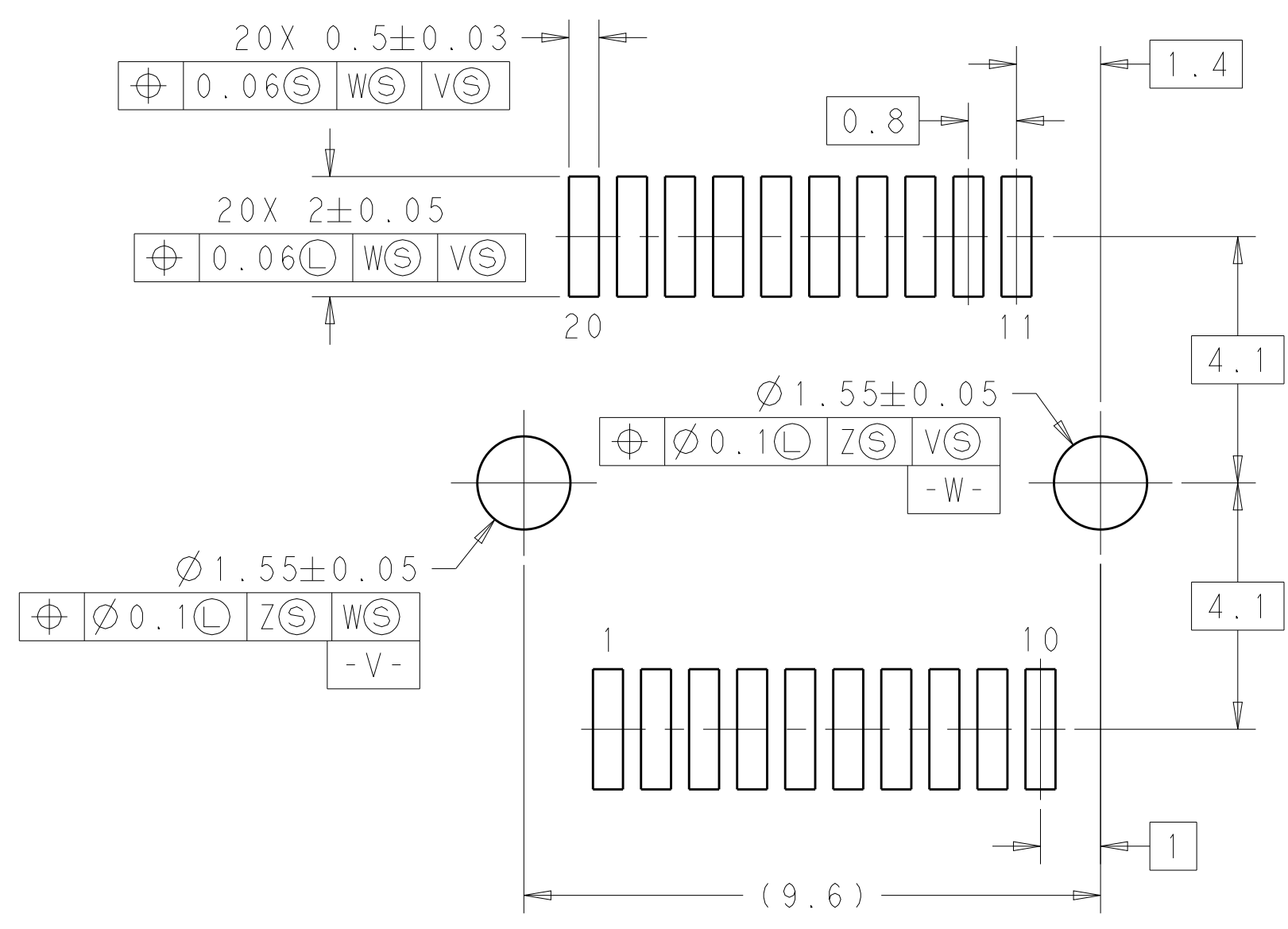

DETAIL A  
 6X INDIVIDUALLY  
 SCALE 10:1

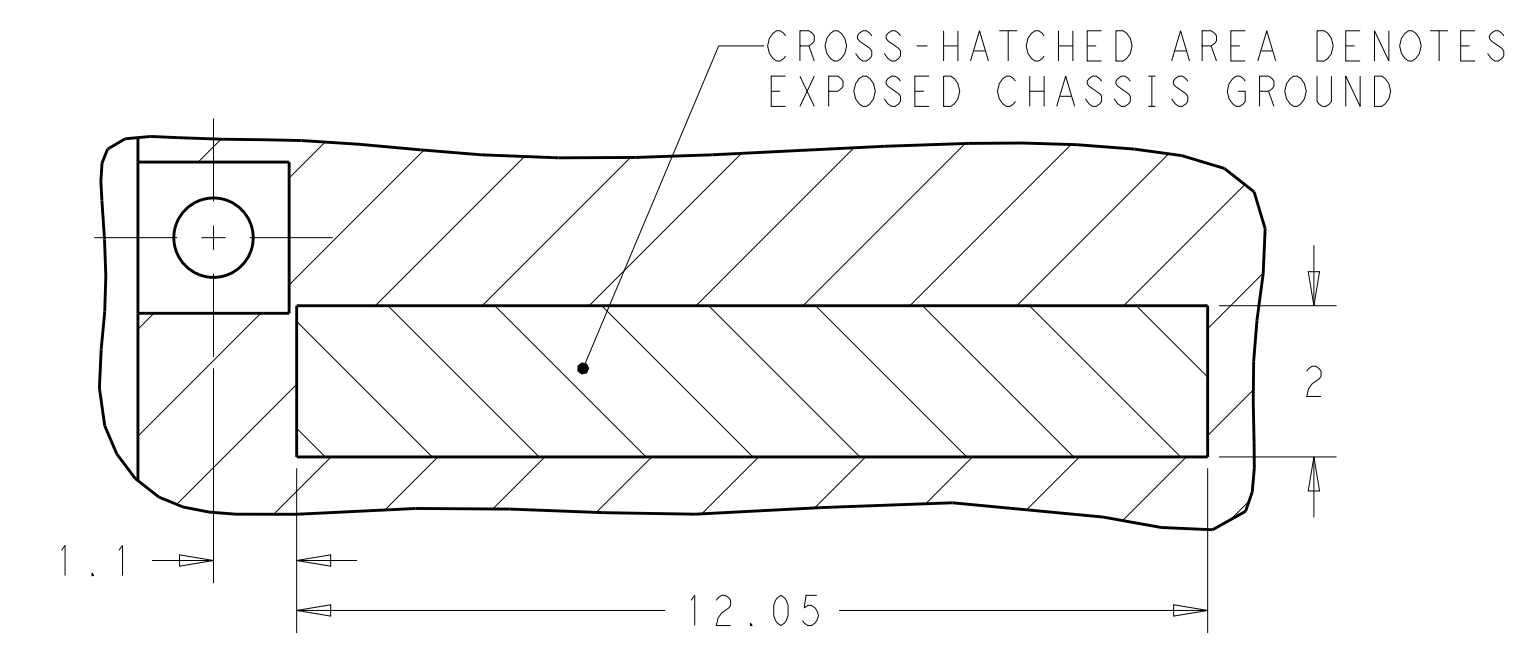

DETAIL B  
 6X INDIVIDUALLY  
 SCALE 10:1

THIS DRAWING IS A CONTROLLED DOCUMENT.		OWN: M. E. CONNER 24JAN2013	TE Connectivity
DIMENSIONS: mm		CHK: M. D. MORRISON 01FEB2013	
TOLERANCES UNLESS OTHERWISE SPECIFIED:		APVD: M. J. PHILLIPS 01FEB2013	NAME: CAGE ASSEMBLY WITH LIGHT PIPES, ENHANCED, PRESS-FIT, 1X6, zSFP+
0 PLC ±0.1 1 PLC ±0.1 2 PLC ±0.8 3 PLC ±0.5 4 PLC ±0.5 ANGLES ±1°		PRODUCT SPEC: -	APPLICATION SPEC: -
MATERIAL: SEE NOTES		FINISH: SEE NOTES	WEIGHT: -
SCALE: 4:1		SIZE: A1	CAGE CODE: 100779
SHEET: 3 OF 4		DRAWING NO: 2198723	REV: B

LOC		DIST		REVISIONS				
P	LTN	DESCRIPTION	DATE	DMN	APVD			
-	-	SEE SHEET 1	-	-	-			

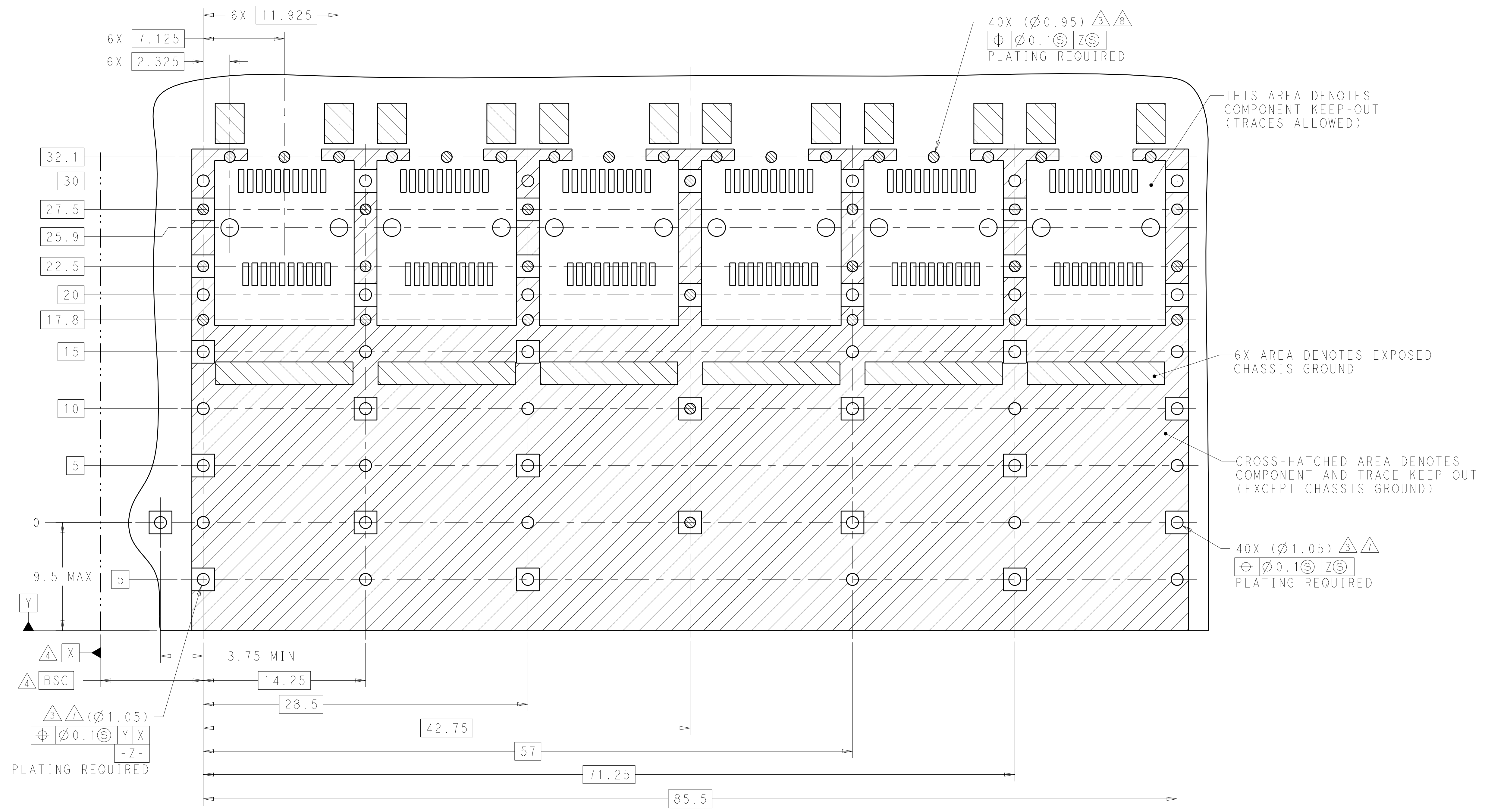

RECOMMENDED PCB CONFIGURATION  
 WITH KEEP-OUT AREAS FOR BELLY TO BELLY APPLICATION  
 SAME AS SINGLE SIDED APPLICATION, EXCEPT AS SHOWN  
 SCALE 5:1

THIS DRAWING IS A CONTROLLED DOCUMENT.		DMN: M.E. CONNER 24JAN2013	TE Connectivity
DIMENSIONS: mm		CHK: M.D. MORRISON 01FEB2013	
TOLERANCES UNLESS OTHERWISE SPECIFIED:		APVD: M.J. PHILLIPS 01FEB2013	NAME: CAGE ASSEMBLY WITH LIGHT PIPES, ENHANCED, PRESS-FIT, 1X6, zSFP+
0 PLC ±0.1 1 PLC ±0.1 2 PLC ±0.8 3 PLC ±0.5 4 PLC ± ANGLES ±1°		PRODUCT SPEC: -	SIZE: A1
MATERIAL: SEE NOTES		APPLICATION SPEC: -	CAGE CODE: 2198723
FINISH: SEE NOTES		WEIGHT: -	RESTRICTED TO: -
		Customer Drawing	SCALE: 4:1 SHEET 4 OF 4 REV B