

FEATURES

- Small and thin 3 mm × 4 mm × 1 mm surface-mount package
- High SNR of 61 dBA
- High sensitivity of -26 dBFS
- Flat frequency response from 100 Hz to 15 kHz
- Low current consumption: <650 μA
- Sleep mode for extended battery life
- High PSRR of 80 dBFS
- Fourth-order Σ-Δ modulator
- Digital PDM output
- Compatible with Sn/Pb and Pb-free solder processes
- RoHS/WEEE compliant

APPLICATIONS

- Smartphones and feature phones
- Teleconferencing systems
- Digital video cameras
- Bluetooth headsets
- Video phones
- Tablets

GENERAL DESCRIPTION

The ADMP421 is a high performance, low power, digital output bottom-ported omnidirectional MEMS microphone. The ADMP421 consists of a MEMS microphone element and an impedance converter amplifier followed by a fourth-order Σ-Δ modulator. The digital interface allows for the pulse density modulated (PDM) output of two microphones to be time-multiplexed on a single data line using a single clock.

The ADMP421 has a high SNR and high sensitivity, making it an excellent choice for far field applications. The ADMP421 has a flat wideband frequency response, resulting in natural sound with high intelligibility. Low current consumption and a sleep mode enable long battery life for portable applications. A built-in particle filter provides high reliability. The ADMP421 complies with the TIA-920 *Telecommunications Telephone Terminal Equipment Transmission Requirements for Wideband Digital Wireline Telephones* standard.

The ADMP421 is available in a thin 3 mm × 4 mm × 1 mm surface-mount package. It is reflow solder compatible with no sensitivity degradation. The ADMP421 is halide free.

FUNCTIONAL BLOCK DIAGRAM

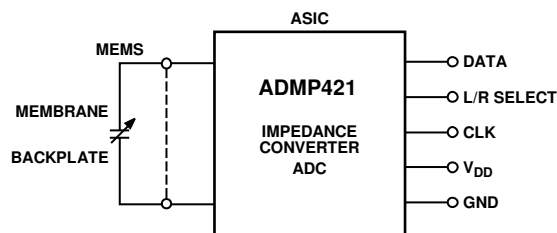

Figure 1.

Rev. A

Information furnished by Analog Devices is believed to be accurate and reliable. However, no responsibility is assumed by Analog Devices for its use, nor for any infringements of patents or other rights of third parties that may result from its use. Specifications subject to change without notice. No license is granted by implication or otherwise under any patent or patent rights of Analog Devices. Trademarks and registered trademarks are the property of their respective owners.

TABLE OF CONTENTS

Features	1	Power Savings When Disabling One Microphone in a Multimicrophone Application.....	8
Applications.....	1	PCB Land Pattern Layout.....	9
General Description	1	Evaluation Board	10
Functional Block Diagram	1	Interfacing With Analog Devices Codecs	11
Revision History	2	Handling Instructions.....	12
Specifications.....	3	Pick-and-Place Equipment	12
Timing Characteristics	4	Reflow Solder	12
Absolute Maximum Ratings.....	5	Board Wash	12
ESD Caution.....	5	Reliability Specifications.....	13
Pin Configuration and Function Descriptions.....	6	Outline Dimensions	14
Typical Performance Characteristics	7	Ordering Guide	14
Power-Saving Features	8		
Sleep Mode	8		

REVISION HISTORY

2/11—Rev. 0 to Rev. A

Changes to Features Section, Applications Section, and General Description Section.....	1
Added Dynamic Range Parameter, Changes to Input Characteristics Parameter and Output Characteristics Parameter, Deleted Polarity Parameter, Table 1	3
Changes to Table 3.....	5
Changes to Table 5.....	6
Added Power-Saving Features Section	8
Updated Outline Dimensions	13
Changes to Ordering Guide	13

4/10—Revision 0: Initial Version

SPECIFICATIONS

$T_A = 25^\circ\text{C}$, $V_{DD} = 1.8\text{ V}$, $\text{CLK} = 2.4\text{ MHz}$, unless otherwise noted. All minimum and maximum specifications are guaranteed. Typical specifications are not guaranteed.

Table 1.

Parameter	Symbol	Test Conditions/Comments	Min	Typ	Max	Unit
PERFORMANCE						
Directionality				Omni		
Sensitivity ¹		1 kHz, 94 dB SPL	-29	-26	-23	dBFS
Signal-to-Noise Ratio	SNR	20 kHz bandwidth, A-weighted		61		dB
Equivalent Input Noise	EIN	20 kHz bandwidth, A-weighted		33		dB
Dynamic Range		Derived from EIN and maximum acoustic input		87		dB
Frequency Response ²		Low frequency -3 dB point		100		Hz
		High frequency -3 dB point		15		kHz
		Deviation limits from flat response within pass band		-3/+2		dB
Total Harmonic Distortion	THD	105 dB SPL			3	%
Power Supply Rejection Ratio	PSRR	217 Hz, 100 mV p-p square wave superimposed on $V_{DD} = 1.8\text{ V}$		80		dBFS
Maximum Acoustic Input		Peak		120		dB SPL
INPUT CHARACTERISTICS						
Clock Frequency	CLK			2.4 ³		MHz
Clock Duty Ratio		Clock frequency of 2.4 MHz or less	40		60	%
Input Voltage High	V_{IH}		$0.65 \times V_{DD}$			V
Input Voltage Low	V_{IL}				$0.35 \times V_{DD}$	V
Supply Voltage	V_{DD}		1.65		3.6	V
Supply Current	I_S	Normal mode			650	μA
		Sleep mode ⁴			50	μA
OUTPUT CHARACTERISTICS						
Output Voltage High	V_{OH}	$I_{LOAD} = 0.5\text{ mA}$	$0.7 \times V_{DD}$	V_{DD}		V
Output Voltage Low	V_{OL}	$I_{LOAD} = 0.5\text{ mA}$		0	$0.3 \times V_{DD}$	V
Latency				<30		μs
Wake-Up Time		From sleep mode, power on		10		ms

¹ Relative to the rms level of a sine wave with positive amplitude equal to 100% 1s density and negative amplitude equal to 0% 1s density.

² See Figure 5 and Figure 6.

³ The microphone operates at any clock frequency between 1.0 MHz and 3.3 MHz. Some specifications may not be guaranteed at frequencies other than 2.4 MHz.

⁴ The microphone enters sleep mode when the clock is turned off or the clock frequency is less than 1 kHz.

ADMP421

TIMING CHARACTERISTICS

Table 2.

Parameter	Description	Min	Max	Unit
Input t_{CLKIN}	Input clock period	310	1000	ns
Output t_{1OUTEN}	DATA1 driven after falling clock edge	30		ns
$t_{1OUTDIS}$	DATA1 disabled after rising clock edge		20	ns
t_{2OUTEN}	DATA2 driven after rising clock edge	30		ns
$t_{2OUTDIS}$	DATA2 disabled after falling clock edge		20	ns

Timing Diagram

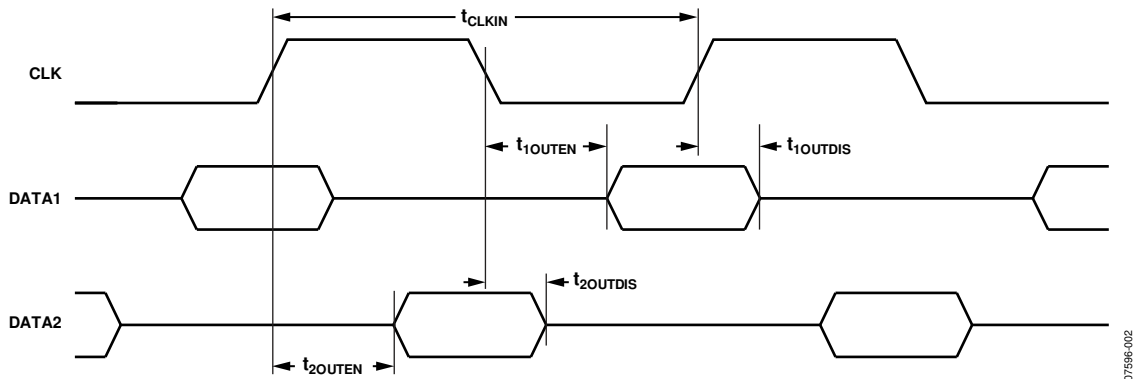

Figure 2. Pulse Density Modulated Output Timing

07558-002

ABSOLUTE MAXIMUM RATINGS

Table 3.

Parameter	Rating
Supply Voltage	-0.3 V to 3.6 V
Digital Pin Input Voltage	-0.3 V to $V_{DD} + 0.3$ V or 3.6 V, whichever is less
Sound Pressure Level (SPL)	160 dB
Mechanical Shock	10,000 g
Vibration	Per MIL-STD-883 Method 2007, Test Condition B
Temperature Range	-40°C to +70°C

Stresses above those listed under Absolute Maximum Ratings may cause permanent damage to the device. This is a stress rating only; functional operation of the device at these or any other conditions above those indicated in the operational section of this specification is not implied. Exposure to absolute maximum rating conditions for extended periods may affect device reliability.

ESD CAUTION



ESD (electrostatic discharge) sensitive device. Charged devices and circuit boards can discharge without detection. Although this product features patented or proprietary protection circuitry, damage may occur on devices subjected to high energy ESD. Therefore, proper ESD precautions should be taken to avoid performance degradation or loss of functionality.

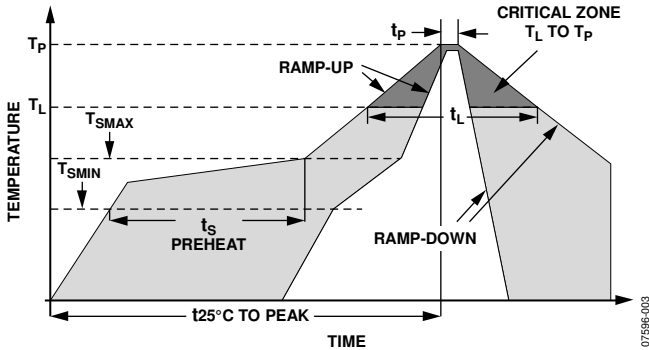

Figure 3. Recommended Soldering Profile Limits

Table 4. Recommended Soldering Profile Limits

Profile Feature	Sn63/Pb37	Pb Free
Average Ramp Rate (T_L to T_P)	3°C/sec max	3°C/sec max
Preheat		
Minimum Temperature (T_{SMIN})	100°C	150°C
Maximum Temperature (T_{SMAX})	150°C	200°C
Time (T_{SMIN} to T_{SMAX}), t_S	60 sec to 120 sec	60 sec to 120 sec
Ramp-Up Rate (T_{SMAX} to T_L)	3°C/sec	3°C/sec
Time Maintained Above Liquidous (t_L)	60 sec to 150 sec	60 sec to 150 sec
Liquidous Temperature (T_L)	183°C	217°C
Peak Temperature (T_P)	240°C +0°C/-5°C	260°C +0°C/-5°C
Time Within 5°C of Actual Peak Temperature (t_P)	10 sec to 30 sec	20 sec to 40 sec
Ramp-Down Rate	6°C/sec max	6°C/sec max
Time 25°C ($t_{25°C}$) to Peak Temperature	6 minute max	8 minute max

PIN CONFIGURATION AND FUNCTION DESCRIPTIONS

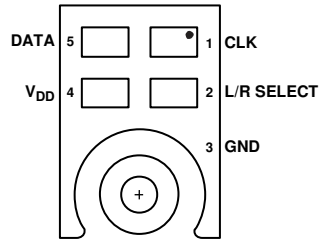

Figure 4. Pin Configuration (Bottom View)

Table 5. Pin Function Descriptions

Pin No.	Mnemonic	Description
1	CLK	Clock Input to Microphone.
2	L/R SELECT	Left Channel or Right Channel Select. DATA1 (right): L/R SELECT tied to GND. DATA2 (left): L/R SELECT pulled to V _{DD} .
3	GND	Ground.
4	V _{DD}	Power Supply. Placing a 0.1 μ F (100 nF) ceramic type X7R capacitor between Pin 4 (V _{DD}) and ground is strongly recommended for best performance and to avoid potential parasitic artifacts. The capacitor should be placed as close to Pin 4 as possible.
5	DATA	Digital Output Signal (DATA1, DATA2).

TYPICAL PERFORMANCE CHARACTERISTICS

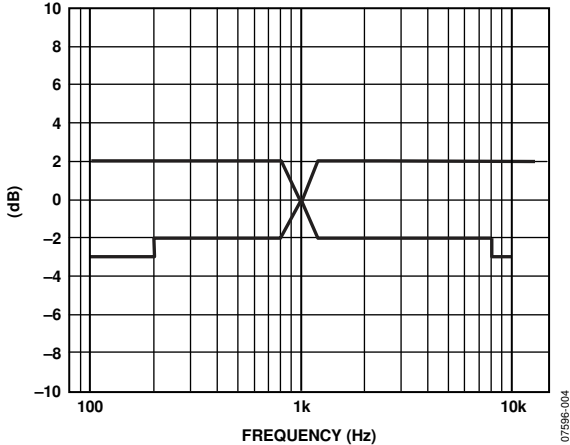

Figure 5. Frequency Response Mask

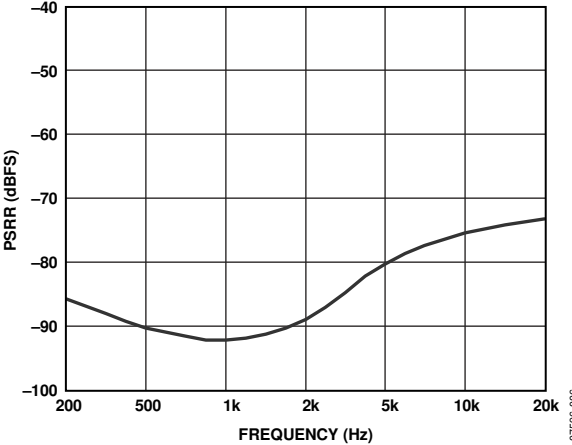

Figure 7. Typical Power Supply Rejection Ratio vs. Frequency

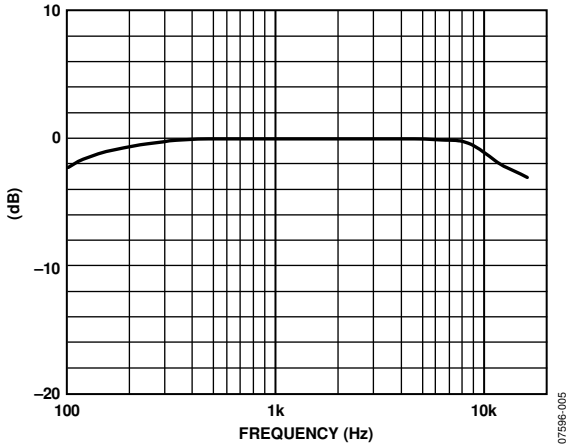

Figure 6. Typical Frequency Response (Measured)

POWER-SAVING FEATURES

SLEEP MODE

The microphone enters sleep mode when the clock is turned off or the clock frequency falls below 1 kHz. In sleep mode, the microphone data output is in high impedance state and the current consumption is less than 50 μ A.

POWER SAVINGS WHEN DISABLING ONE MICROPHONE IN A MULTIMICROPHONE APPLICATION

The ADMP421 has a unique power-saving feature when used in systems where two or more microphones share the same clock and/or data lines. The microphone is designed to present high impedance on both the clock and data pins when the power supply (V_{DD}) pin is at 0 V or floating. This disabled microphone presents no load to and consumes no power from other active microphones.

PCB LAND PATTERN LAYOUT

The recommended PCB land pattern for the ADMP421 should be laid out to a 1:1 ratio to the solder pads on the microphone package, as shown in Figure 8. Care should be taken to avoid applying solder paste to the sound hole in the PCB. A suggested

solder paste stencil pattern layout is shown in Figure 9. The diameter of the sound hole in the PCB should be larger than the diameter of the sound port of the microphone. A minimum diameter of 0.5 mm is recommended.

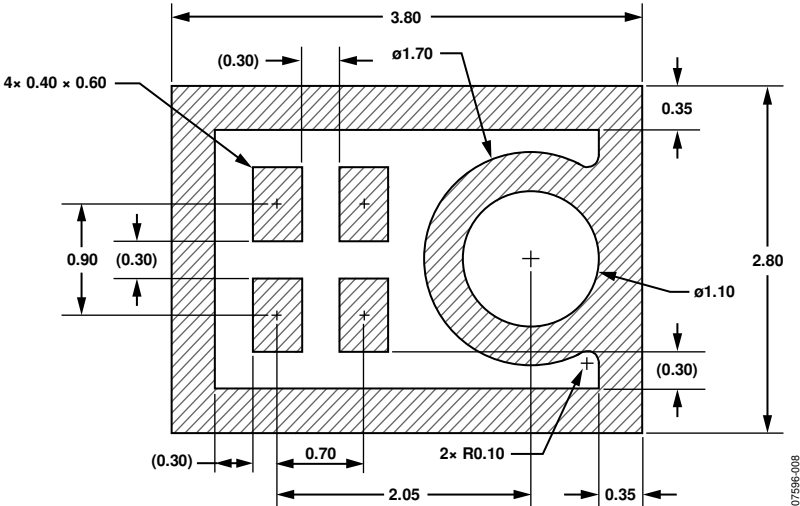

Figure 8. Suggested PCB Land Pattern Layout

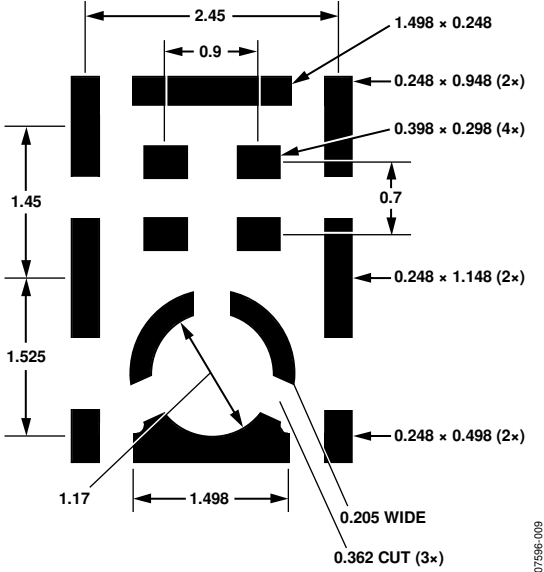

Figure 9. Suggested Solder Paste Stencil Pattern Layout

ADMP421

EVALUATION BOARD

Figure 10 and Figure 11 show the ADMP421 evaluation board schematic and layout, respectively. The ADMP421 evaluation board is designed to plug directly into Connector J6 on the Analog Devices, Inc., [EVAL-ADAU1761Z](#).

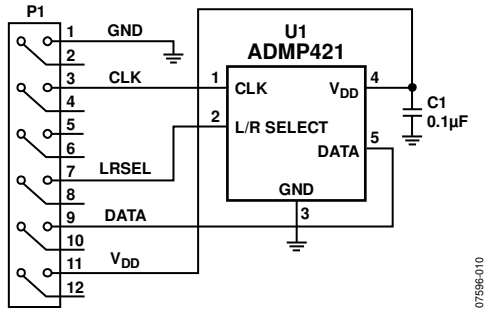

Figure 10. ADMP421 Evaluation Board Schematic

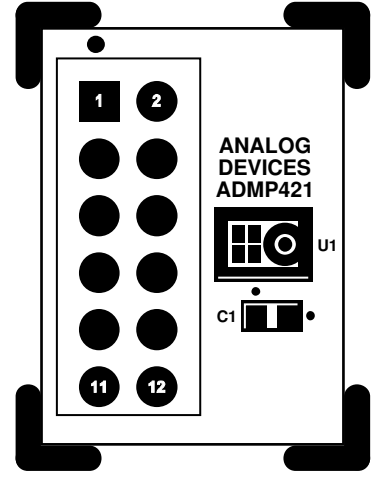

Figure 11. ADMP421 Evaluation Board Layout

Table 6. Evaluation Board Connector Pin Functions

Pin No.	Description	Pin No.	Description
1	GND	2	Not connected
3	CLK	4	Not connected
5	Not connected	6	Not connected
7	L/R SELECT	8	Not connected
9	DATA	10	Not connected
11	V _{DD}	12	Not connected

INTERFACING WITH ANALOG DEVICES CODECS

Analog Devices [ADAU1361](#) and [ADAU1761](#) codecs feature digital microphone inputs that support the ADMP421 PDM output data format. See the connection diagrams shown in

Figure 12 and Figure 13, and refer to the [AN-1003 Application Note](#) and the codecs' respective data sheets for more details on the digital microphone interface.

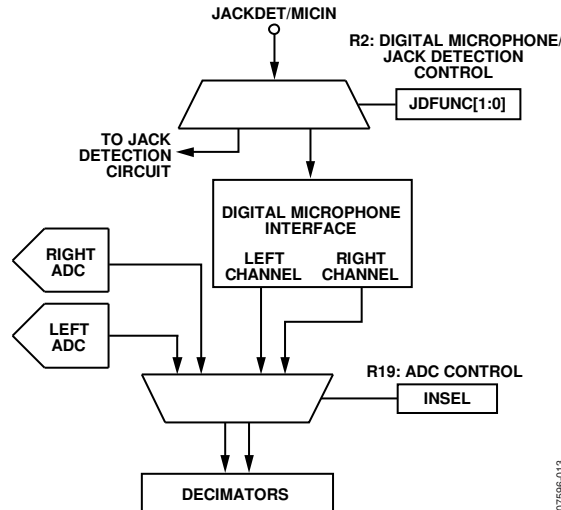

Figure 12. Digital Microphone Signal Routing Block Diagram

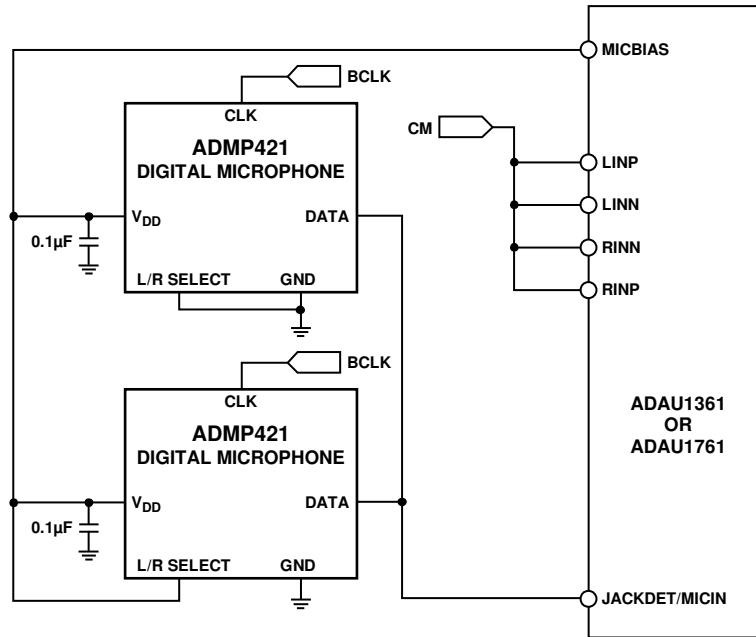

Figure 13. ADAU1361 and ADAU1761 Stereo Interface Block Diagram

HANDLING INSTRUCTIONS

PICK-AND-PLACE EQUIPMENT

The MEMS microphone can be handled using standard pick-and-place and chip shooting equipment. Care should be taken to avoid damage to the MEMS microphone structure as follows:

- Use a standard pickup tool to handle the microphone. Because the microphone hole is on the bottom of the package, the pickup tool can make contact with any part of the lid surface.
- Use care during pick-and-place to ensure that no high shock events above 20 kg are experienced because such events may cause damage to the microphone.
- Do not pick up the microphone with a vacuum tool that makes contact with the bottom side of the microphone. Do not pull air out of or blow air into the microphone port.
- Do not use excessive force to place the microphone on the PCB.

REFLOW SOLDER

For best results, the soldering profile should be in accordance with the recommendations of the manufacturer of the solder paste used to attach the MEMS microphone to the PCB. It is recommended that the solder reflow profile not exceed the limit conditions specified in Figure 3 and Table 4.

BOARD WASH

When washing the PCB, ensure that water does not make contact with the microphone port. Blow-off procedures and ultrasonic cleaning must not be used.

RELIABILITY SPECIFICATIONS

The microphone sensitivity after stress must deviate by no more than 3 dB from the initial value.

Table 7.

Stress Test	Description
Low Temperature Operating Life	-40°C, 500 hours, powered
High Temperature Operating Life	+125°C, 500 hours, powered
Temperature Humidity Bias (THB)	+65°C/85% relative humidity (RH), 500 hours, powered
Temperature Cycle	-40°C/+125°C, one cycle per hour, 100 cycles
High Temperature Storage	150°C, 500 hours
Low Temperature Storage	-40°C, 500 hours
Component CDM ESD	All pins, 0.5 kV
Component HBM ESD	All pins, 1.5 kV
Component MM ESD	All pins, 0.2 kV

ADMP421

OUTLINE DIMENSIONS

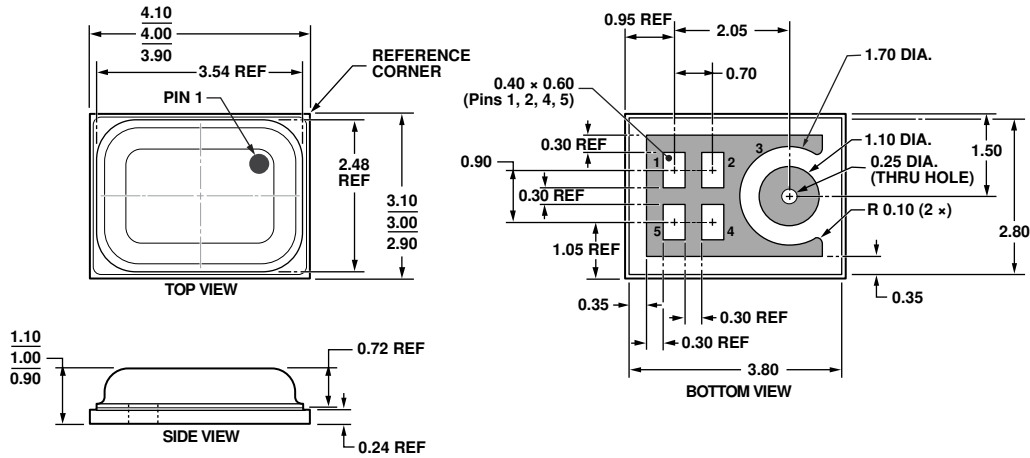
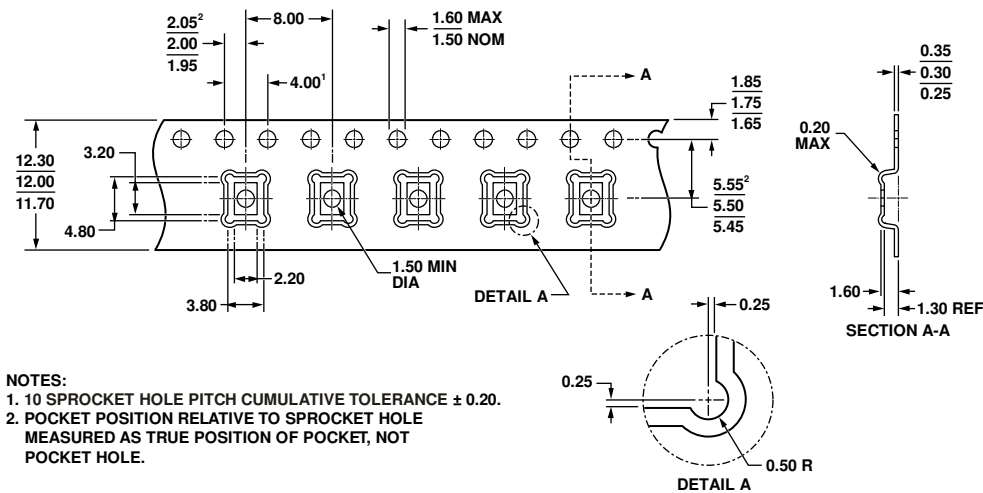

Figure 14. 5-Terminal Chip Array Small Outline No Lead Cavity [LGA_CAV]
4 mm x 3 mm Body
(CE-5-1)
Dimensions shown in millimeters



- NOTES:
1. 10 SPROCKET HOLE PITCH CUMULATIVE TOLERANCE ± 0.20 .
2. POCKET POSITION RELATIVE TO SPROCKET HOLE MEASURED AS TRUE POSITION OF POCKET, NOT POCKET HOLE.

Figure 15. LGA_CAV Tape and Reel Outline Dimensions
Dimensions shown in millimeters

ORDERING GUIDE

Model ¹	Temperature Range	Package Description	Package Option ²	Ordering Quantity
ADMP421ACEZ-RL	-40°C to +70°C	5-Terminal LGA_CAV, 13" Tape and Reel	CE-5-1	5,000
ADMP421ACEZ-RL7	-40°C to +70°C	5-Terminal LGA_CAV, 7" Tape and Reel	CE-5-1	1,000
EVAL-ADMP421Z		Evaluation Board		
EVAL-ADMP421Z-FLEX		FLEX Evaluation Board		

¹ Z = RoHS Compliant Part.

² This package option is halide free.

NOTES

ADMP421

NOTES