



# 0.1%-Accurate Signal Conditioner for Piezoresistive Sensor Compensation

## General Description

The MAX1457 is a highly integrated analog-sensor signal processor optimized for piezoresistive sensor calibration and compensation. It includes a programmable current source for sensor excitation, a 3-bit programmable-gain amplifier (PGA), a 12-bit ADC, five 16-bit DACs, and an uncommitted op amp. Achieving a total error factor within 0.1% of the sensor's repeatability errors, the MAX1457 compensates offset, full-span output (FSO), offset TC, FSO TC, and full-span output non-linearity of silicon piezoresistive sensors.

The MAX1457 calibrates and compensates first-order temperature errors by adjusting the offset and span of the input signal via digital-to-analog converters (DACs), thereby eliminating quantization noise. If needed, residual higher-order errors are then compensated using linear interpolation of the first-order coefficients stored in a look-up table (in external EEPROM).

The MAX1457 integrates three traditional sensor-manufacturing operations into one automated process:

- Pretest: Data acquisition of sensor performance under the control of a host test computer.
- Calibration and Compensation: Computation and storage (in an external EEPROM) of calibration and compensation coefficients determined from transducer pretest data.
- Final Test: Verification of transducer calibration and compensation, without removal from a pretest socket.

Analog outputs are provided for both pressure and temperature. A general-purpose, uncommitted op amp is also included on-chip to increase the overall circuit gain, or to facilitate the implementation of a 2-wire, 4–20mA transmitter. The serial interface is compatible with MicroWire™ and SPI™, and directly connects to an external EEPROM. Additionally, built-in testability features of the MAX1457 facilitate manufacturing and calibration of multiple sensor modules, thus lowering manufacturing cost.

Although optimized for use with piezoresistive sensors, the MAX1457 may also be used with other resistive sensor types (i.e., accelerometers and strain gauges) with the addition of a few external components.

## Customization

Maxim can customize the MAX1457 for unique requirements. With a dedicated cell library of more than 90 sensor-specific functional blocks, Maxim can quickly provide customized MAX1457 solutions. Contact Maxim for additional information.

*Rail-to-Rail is a registered trademark of Nippon Motorola, Ltd.*

*SPI is a trademark of Motorola, Inc.*

*MicroWire is a trademark of National Semiconductor Corp.*



## Features

- ◆ High Accuracy (within  $\pm 0.1\%$  of sensor's repeatable errors)
- ◆ Compensates Offset, Offset TC, FSO, FSO TC, Temperature/Pressure Nonlinearity
- ◆ Rail-to-Rail® Analog Output for Calibrated, Temperature-Compensated Pressure Measurements
- ◆ Programmable Sensor Excitation Current
- ◆ SPI/MicroWire-Compatible Serial Interface
- ◆ Fast Signal-Path Settling Time ( $<1\text{ms}$ )
- ◆ Accepts Sensor Outputs from 5mV/V to 30mV/V
- ◆ Pin-Compatible with MCA7707

## Ordering Information

PART	TEMP. RANGE	PIN-PACKAGE
MAX1457CWI	0°C to +70°C	28 Wide SO
MAX1457CCJ	0°C to +70°C	32 TQFP
MAX1457C/D	0°C to +70°C	Dice*

Ordering Information continued at end of data sheet.

Note: Contact the factory for customized solutions.

\*Dice are tested at  $T_A = +25^\circ\text{C}$ .

Pin Configurations appear at end of data sheet.

## Functional Diagram

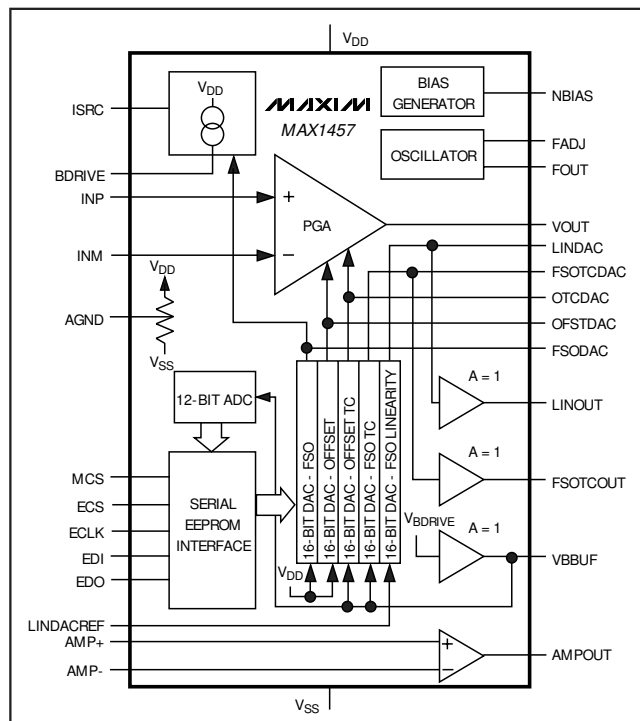

# 0.1%-Accurate Signal Conditioner for Piezoresistive Sensor Compensation

## ABSOLUTE MAXIMUM RATINGS

Supply Voltage,  $V_{DD}$  to  $V_{SS}$ .....-0.3V to +6V  
 All other pins .....( $V_{SS} - 0.3V$ ) to ( $V_{DD} + 0.3V$ )  
 Continuous Power Dissipation ( $T_A = +70^\circ\text{C}$ )  
   28-Pin Wide SO (derate 12.50mW/ $^\circ\text{C}$  above +70 $^\circ\text{C}$ ) .....1W  
   32-Pin TQFP (derate 11.1mW/ $^\circ\text{C}$  above +70 $^\circ\text{C}$ ).....889mW

Operating Temperature Ranges  
 MAX1457C\_.....0 $^\circ\text{C}$  to +70 $^\circ\text{C}$   
 MAX1457A\_.....-40 $^\circ\text{C}$  to +125 $^\circ\text{C}$   
 Storage Temperature Range .....-65 $^\circ\text{C}$  to +150 $^\circ\text{C}$   
 Lead Temperature (soldering, 10sec) .....+300 $^\circ\text{C}$

Stresses beyond those listed under "Absolute Maximum Ratings" may cause permanent damage to the device. These are stress ratings only, and functional operation of the device at these or any other conditions beyond those indicated in the operational sections of the specifications is not implied. Exposure to absolute maximum rating conditions for extended periods may affect device reliability.

## ELECTRICAL CHARACTERISTICS

( $V_{DD} = +5V$ ,  $V_{SS} = 0V$ ,  $T_A = +25^\circ\text{C}$ , unless otherwise noted.)

PARAMETER	SYMBOL	CONDITIONS	MIN	TYP	MAX	UNITS
<b>GENERAL CHARACTERISTICS</b>						
Supply Voltage	$V_{DD}$		4.5	5	5.5	V
Supply Current	$I_{DD}$	$R_{BIAS} = 400k\Omega$ , $f_{CLK} = 100kHz$ (Note 1)		2.0	2.6	mA
<b>ANALOG INPUT (PGA)</b>						
Input Impedance	$R_{IN}$			1		$M\Omega$
Input-Referred Offset Tempco		(Notes 2, 3)		$\pm 0.5$		$\mu\text{V}/^\circ\text{C}$
Amplifier Gain Nonlinearity				0.01		% $V_{DD}$
Output Step-Response Time		$f_{CLK} = 100kHz$ , to 63% of final value		1		ms
Common-Mode Rejection Ratio	CMRR	From $V_{SS}$ to $V_{DD}$		90		dB
Input-Referred Adjustable Offset Range		(Note 4)		$\pm 100$		mV
Input-Referred Adjustable Full-Span Output Range		(Note 5)		5 to 30		mV/V
<b>ANALOG OUTPUT (PGA)</b>						
Differential Signal Gain Range				54 to 306		V/V
Minimum Differential Signal Gain		$T_A = T_{MIN}$ to $T_{MAX}$	49	54	60	V/V
Differential Signal Gain Tempco				$\pm 50$		ppm/ $^\circ\text{C}$
Output Voltage Swing		5k $\Omega$ load to $V_{SS}$ or $V_{DD}$	$V_{SS} + 0.25$	$V_{DD} - 0.25$		V
		No load	$V_{SS} + 0.02$	$V_{DD} - 0.02$		
Output Current Range		$V_{OUT} = (V_{SS} + 0.25V)$ to $(V_{DD} - 0.25V)$	-1.0 (sink)	1.0 (source)		mA
Output Noise		Gain = 54, DC to 10Hz, sensor impedance = 5k $\Omega$ , full-span output = 4V		0.0025		%FSO
<b>CURRENT SOURCE</b>						
Bridge Current Range	$I_{BR}$		0.1	0.5	2.0	mA
Bridge Voltage Swing	$V_{BR}$		$V_{SS} + 1.3$		$V_{DD} - 1.3$	V
Current-Source Reference Input Voltage Range	$V_{ISRC}$		$V_{SS} + 1.3$		$V_{DD} - 1.3$	V
<b>DIGITAL-TO-ANALOG CONVERTERS</b>						
DAC Voltage Resolution		Reference voltage = 5.000V		200		$\mu\text{V}$
Differential Nonlinearity		Output filter capacitor = 0.1 $\mu\text{F}$ , $f_{CLK} = 100kHz$		2		LSB
DAC Resolution					16	Bits

# 0.1%-Accurate Signal Conditioner for Piezoresistive Sensor Compensation

MAX1457

## ELECTRICAL CHARACTERISTICS (continued)

(V<sub>DD</sub> = +5V, V<sub>SS</sub> = 0V, T<sub>A</sub> = +25°C, unless otherwise noted.)

PARAMETER	SYMBOL	CONDITIONS	MIN	TYP	MAX	UNITS
<b>ANALOG-TO-DIGITAL CONVERTER</b>						
ADC Differential Nonlinearity		V <sub>BR</sub> = 2.5V to 3.5V, f <sub>CLK</sub> = 100kHz		2		LSB
Conversion Time		f <sub>CLK</sub> = 100kHz		160		ms
ADC Resolution					12	Bits
<b>OUTPUTS (LINDAC, FSOTCDAC)</b>						
Voltage Swing		R <sub>BIAS</sub> = 400kΩ (no load)	V <sub>SS</sub> + 1.3		V <sub>DD</sub> - 1.3	V
Current Drive		R <sub>BIAS</sub> = 400kΩ, V <sub>IN</sub> = 2.5V, V <sub>OUT</sub> = 2.5V ± 20mV	-50		50	μA
Offset Voltage	V <sub>OFS</sub>	(V <sub>IN</sub> - V <sub>OUT</sub> ) at V <sub>IN</sub> = 2.5V, R <sub>BIAS</sub> = 400kΩ (no load)	-20		20	mV
<b>UNCOMMITTED OP AMP</b>						
Input Common-Mode Voltage Range	CMR		V <sub>SS</sub> + 1.3		V <sub>DD</sub> - 1.2	V
Open-Loop Gain	A <sub>V</sub>	R <sub>BIAS</sub> = 400kΩ		60		dB
Offset Voltage (as unity-gain follower)		R <sub>BIAS</sub> = 400kΩ, V <sub>IN</sub> = 2.5V (no load)	-20		20	mV
Output Voltage Swing		5kΩ load to V <sub>SS</sub> or V <sub>DD</sub>	V <sub>SS</sub> + 0.25		V <sub>DD</sub> - 0.25	V
		No load	V <sub>SS</sub> + 0.02		V <sub>DD</sub> - 0.02	
Output Current Range		V <sub>OUT</sub> = (V <sub>SS</sub> + 0.25V) to (V <sub>DD</sub> - 0.25V)	-1.0 (sink)		1.0 (source)	mA

**Note 1:** Circuit of Figure 5 with current source turned off. This value is adjustable through a bias resistor and represents the IC current consumption. This excludes the 93C66 EEPROM average current, which is approximately 13μA at a refresh rate of 3Hz (f<sub>CLK</sub> = 100kHz).

**Note 2:** Temperature errors for the entire range are compensated together with the sensor errors.

**Note 3:** The sensor and the MAX1457 must always be at the same temperature during calibration and use.

**Note 4:** This is the maximum allowable sensor offset at minimum gain (54V/V).

**Note 5:** This is the sensor's sensitivity normalized to its drive voltage, assuming a desired full-span output of 4V and a bridge voltage of 2.5V. Lower sensitivities can be accommodated by using the auxiliary op amp. Higher sensitivities can be accommodated by operating at lower bridge voltages.

# 0.1%-Accurate Signal Conditioner for Piezoresistive Sensor Compensation

## Pin Description

PIN		NAME	FUNCTION
SO	TQFP		
1	28	INP	Positive Sensor Input. Input impedance >1M $\Omega$ . Rail-to-rail input range.
2	29	INM	Negative Sensor Input. Input impedance >1M $\Omega$ . Rail-to-rail input range.
3	30	AMP+	Positive Input of General-Purpose Operational Amplifier
4	31	AMP-	Negative Input of General-Purpose Operational Amplifier
5	1	AMPOUT	Output of General-Purpose Operational Amplifier. High impedance when MCS is low.
6	2	BDRIVE	Sensor Excitation Current. This pin drives a nominal 0.5mA through the sensor.
7	3	VOUT	PGA Output Voltage. Connect a 0.1 $\mu$ F capacitor from VOUT to V <sub>SS</sub> . High impedance when MCS is low.
—	4, 16, 22, 32	N.C.	Not internally connected.
8	5	ISRC	Current-Source Reference. Connect a 50k $\Omega$ resistor from ISRC to V <sub>SS</sub> .
9	6	FSOTCOUT	Buffered FSO TC DAC Output. Tie to ISRC with a resistor (R <sub>STC</sub> $\geq$ 50k $\Omega$ ).
10	7	VBBUF	Buffered Bridge Voltage (the voltage at BDRIVE). Leave unconnected if unused.
11	8	LINOUT	Buffered FSO Linearity DAC Output. Use a resistor (R <sub>LIN</sub> ) greater than 100k $\Omega$ , from LINOUT to ISRC to correct second order FSO nonlinearity errors. Leave unconnected if not correcting second order FSO nonlinearity errors.
12	9	LINDACREF	Reference Input to FSO Linearity DAC. Normally tied to VOUT.
13	10	LINDAC	FSO Linearity DAC Output Voltage. Connect 0.1 $\mu$ F capacitor from LINDAC to V <sub>SS</sub> .
14	11	V <sub>SS</sub>	Negative Power Supply Input
15	12	OTCDAC	OFFSET TC DAC Output Voltage. Connect a 0.1 $\mu$ F capacitor from OTCDAC to V <sub>SS</sub> .
16	13	FSODAC	FSO DAC Output Voltage. Connect a 0.1 $\mu$ F capacitor from FSODAC to V <sub>SS</sub> .
17	14	FSOTCDAC	FSO TC DAC Output Voltage. Connect a 0.1 $\mu$ F capacitor from FSOTCDAC to V <sub>SS</sub> .
18	15	OFSTDAC	OFFSET DAC Output Voltage. Connect a 0.1 $\mu$ F capacitor from OFSTDAC to V <sub>SS</sub> .
19	17	EDO	Serial Input (data from EEPROM), active high. CMOS logic-level input pin through which the MAX1457's internal registers are updated with EEPROM coefficients. Disabled when MCS is low.
20	18	EDI	Serial Output (data to EEPROM), active high. CMOS logic-level output pin through which the MAX1457 gives external commands to the EEPROM. Temperature-compensation data is available through this pin. Becomes high impedance when MCS is low.
21	19	ECLK	CMOS Logic-Level Clock Output for external EEPROM. High impedance when MCS is low.
22	20	ECS	Chip-Select Output for external EEPROM. CMOS logic-level output pin through which the MAX1457 enables/disables EEPROM operation. High impedance when MCS is low.
23	21	FOUT	Frequency Output. Internal oscillator output signal. Normally left open.
24	23	FADJ	Frequency Adjust. Connect to V <sub>SS</sub> with a 1.5M $\Omega$ resistor (R <sub>OSC</sub> ) to set internal oscillator frequency to 100kHz. Connect a 0.1 $\mu$ F bypass capacitor from FADJ to V <sub>SS</sub> .
25	24	MCS	Master Chip Select. The MAX1457 is selected when MCS is high. Leave unconnected for normal operation (internally pulled up to V <sub>DD</sub> with 1M $\Omega$ resistor). External 5k $\Omega$ pull-up may be required in noisy environments.
26	25	NBIAS	Bias Setting Pin. Connect to V <sub>DD</sub> with a 400k $\Omega$ resistor (R <sub>BIAS</sub> ). Connect a 0.1 $\mu$ F bypass capacitor from NBIAS to V <sub>SS</sub> .
27	26	AGND	Mid-Supply Reference for Analog Circuitry. Connect a 0.1 $\mu$ F capacitor from V <sub>SS</sub> to AGND.
28	27	V <sub>DD</sub>	Positive Power-Supply Input. Connect a 0.1 $\mu$ F capacitor from V <sub>DD</sub> to V <sub>SS</sub> .

# 0.1%-Accurate Signal Conditioner for Piezoresistive Sensor Compensation

## Detailed Description

The MAX1457 provides an analog amplification path for the sensor signal and a digital path for calibration and temperature correction. Calibration and correction are achieved by varying the offset and gain of a programmable-gain amplifier (PGA) and by varying the sensor bridge current. The PGA utilizes a switched-capacitor CMOS technology, with an input-referred offset trimming range of  $\pm 100\text{mV}$  ( $20\text{mV/V}$ ) and an approximate  $3\mu\text{V}$  (input referred, at minimum gain of  $54\text{V/V}$ ) resolution (16 bits). The PGA provides eight gain values from  $54\text{V/V}$  to  $306\text{V/V}$ . The bridge current source is programmable from  $0.1\text{mA}$  to  $2\text{mA}$ , with a  $15\text{nA}$  step size.

The MAX1457 uses five 16-bit DACs with calibration coefficients stored in a low-cost external EEPROM. This memory (an external 4096-bit EEPROM) contains the following calibration coefficients as 16-bit words:

- FSO (full-span output)
- FSO TC (including nonlinearities)
- Offset
- Offset TC (including nonlinearities)
- Pressure nonlinearity

Figure 1 shows a typical pressure-sensor output and defines the offset, full-scale, and full-span output values as a function of voltage.

## Offset Correction

Initial offset calibration is accomplished by reading a 16-bit word (coefficient) from the EEPROM and writing it to the OFFSET DAC. The resulting voltage (OFSTDAC) is fed into a summing junction at the PGA output for compensating the sensor offset with a resolution of  $\pm 0.2\text{mV}$  ( $\pm 0.005\%$  FSO).

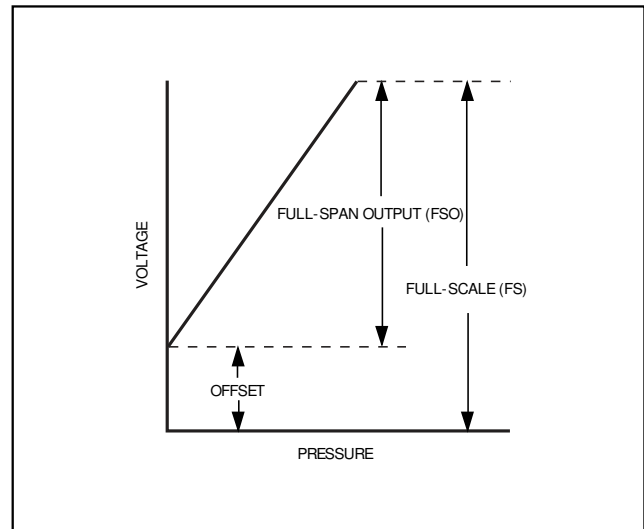

Figure 1. Typical Pressure-Sensor Output

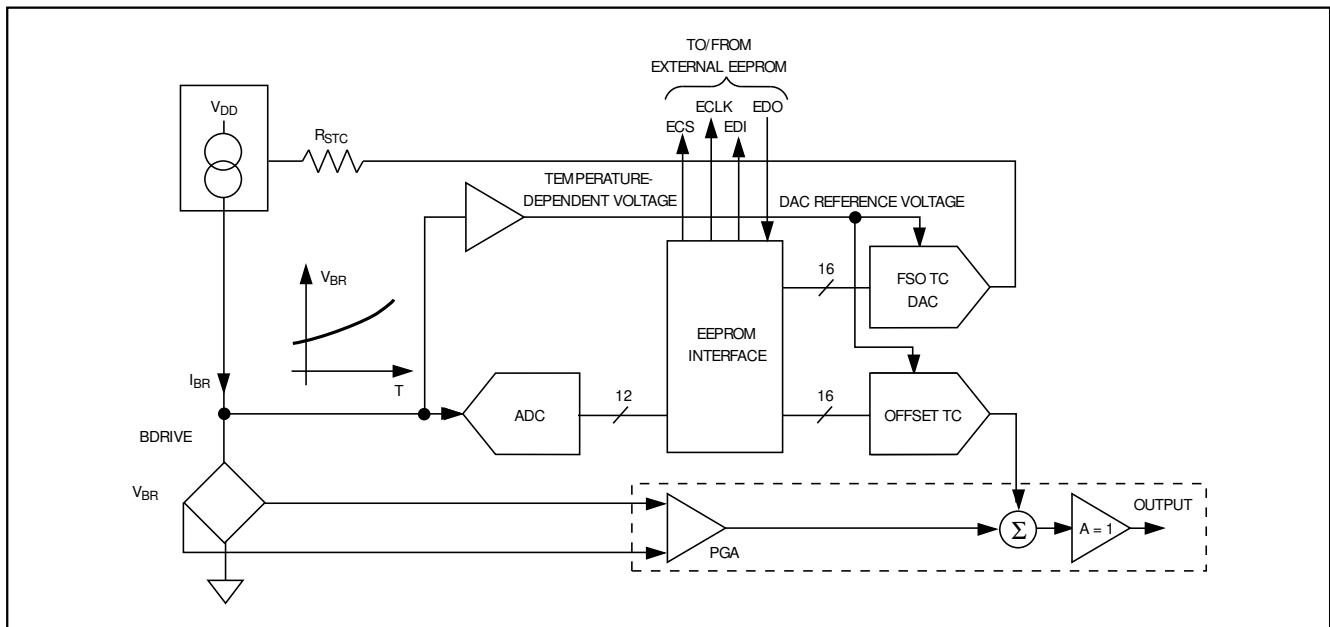

Figure 2. Simplified Diagram of Temperature Error Correction

# 0.1%-Accurate Signal Conditioner for Piezoresistive Sensor Compensation

## FSO Calibration

Two adjustments are required for FSO calibration. First set the coarse gain by digitally selecting the PGA gain. Then calibrate the bridge current by writing a 16-bit calibration coefficient word to the FSO DAC. These two adjustments result in a calibration resolution of  $\pm 0.2\text{mV}$  ( $\pm 0.005\%$  FSO).

## Linear Temperature Compensation

Temperature errors are compensated by writing 16-bit calibration coefficients into the OFFSET TC DAC and the FSO TC DAC (changing the current-source value through resistive feedback from the FSOTCDAC pin to the ISRC pin). The piezoresistive sensor is powered by a current source resulting in a temperature-dependent bridge voltage. The reference inputs of the OFFSET TC DAC and FSO TC DAC are connected to the bridge voltage. For a fixed digital word, the DAC output voltages track the bridge voltage as it varies with temperature (quasi-linearly).

## Multislope Temperature Compensation

The MAX1457 utilizes multislope temperature compensation, allowing for compensation of arbitrary error curves restricted only by the available adjustment range and the shape of the temperature signal.

The MAX1457 offers a maximum of 120 calibration points (each consisting of one OFFSET TC coefficient and one FSO TC coefficient) over the operating temperature range. Each 16-bit calibration coefficient provides compensation of the output (either offset or FSO) with  $\pm 0.2\text{mV}$  (0.005% FSO) resolution. A 12-bit ADC measures the temperature-dependent bridge voltage (BDRIVE) and selects (by addressing the EEPROM) the corresponding offset and FSO calibration data within a specific narrow temperature span (e.g.,  $\cong 1^\circ\text{C}$ ). The 120-segment compensation enables the MAX1457 to compensate temperature errors for a broad range of sensors (Figure 2).

Calculate the correction coefficients by curve-fitting to sensor-error test data. More test points allow for better curve-fit accuracy but result in increased test overhead. The remaining error is further affected by the slope of the temperature errors. For example, correcting a 6% nonlinearity over temperature with 60 segments (half of the available calibration points) with perfect curve fitting yields an error on the order of 0.1% (6%/60). Figure 3 illustrates this compensation.

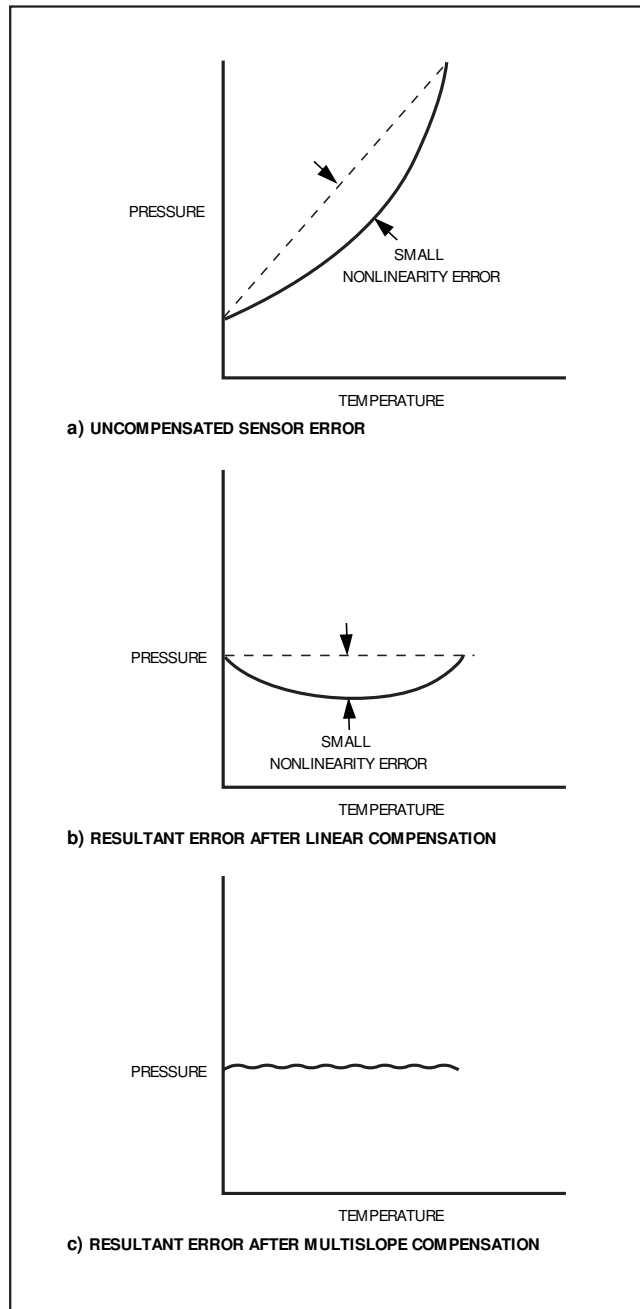

Figure 3. Multislope Temperature Compensation

# 0.1%-Accurate Signal Conditioner for Piezoresistive Sensor Compensation

## Pressure Nonlinearity Correction

The MAX1457 corrects pressure nonlinearity in an analog fashion by providing a resistive feedback path (resistor  $R_{LIN}$  in Figure 4) from a buffered main output (LINOUT pin) to the current source (ISRC pin). The feedback coefficient is then set by writing a 16-bit word to the FSO LIN DAC.

For many silicon sensors, this type of nonlinearity correction may reduce sensor nonlinearity by an order of magnitude.

## Applications Information

### Ratiometric Output Configuration

Ratiometric output configuration provides an output that is proportional to the power-supply voltage. When used with ratiometric ADCs, this output provides digital pressure values independent of supply voltage.

The MAX1457 has been designed to provide a high-performance ratiometric output with a minimum number of external components (Figure 5). These external components typically include an external EEPROM (93C66), decoupling capacitors, and resistors.

### 2-Wire, 4–20mA Configuration

In this configuration, a 4mA current is used to power a transducer, and an incremental current of 0 to 16mA proportional to the measured pressure is transmitted over the same pair of wires. Current output enables long-distance transmission without a loss of accuracy due to cable resistance.

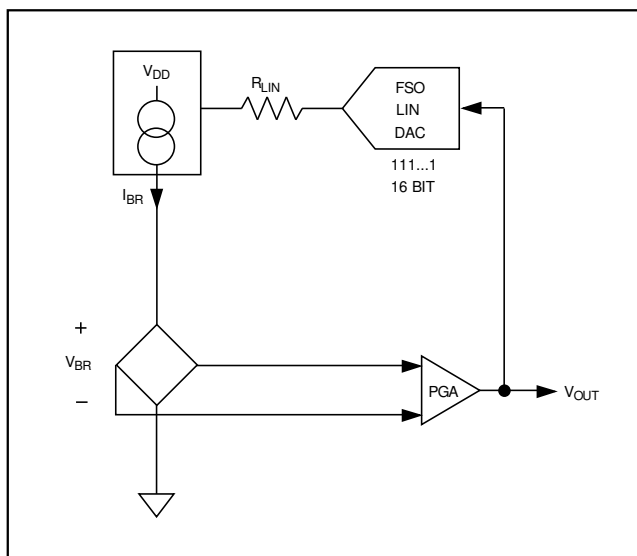

Figure 4. Pressure Nonlinearity Correction

Only a few components (Figure 6) are required to build a 4–20mA output configuration. A low-quiescent-current voltage regulator with a built-in bandgap reference (such as the REF02) should be used. Since the MAX1457 performs temperature and gain compensation of the circuit, the temperature stability and calibration accuracy of the reference voltage is of secondary importance.

The external transistor forms the controllable current loop. The MAX1457 controls the voltage across resistor  $R_A$ . With  $R_A = 50\Omega$ , a 0.2V to 1.0V range would be required during the calibration procedure. If needed, the PGA output can be divided using resistors  $R_B$  and  $R_C$ .

For overvoltage protection, place a Zener diode across  $V_{IN-}$  and  $V_{IN+}$  (Figure 6). A feedthrough capacitor across the inputs reduces EMI/RFI.

### Test System Configuration

The MAX1457 is designed to support an automated production pressure-temperature test system with integrated calibration and temperature compensation. Figure 7 shows the implementation concept for a low-cost test system capable of testing up to five transducer modules connected in parallel. Three-state outputs on the MAX1457 allow for parallel connection of transducers.

The test system shown in Figure 7 includes a dedicated test bus consisting of six wires (the capacitive loading of each transducer module should not exceed the EEPROM fan-out specifications):

- Two power-supply lines
- One analog output voltage line from the transducers to a system digital voltmeter
- Three MicroWire/SPI interface lines: EDI (data-in), EDO (data-out), and ECLK (clock)

For simultaneous testing of more than five transducer modules, use buffers to prevent overloading the data bus.

A digital multiplexer controls the two chip-select signals for each transducer:

- Module Select (MCS) places the selected module into an active state, enabling operation and compensation
- EEPROM Select (ECS) enables writing to the transducer's EEPROM

# 0.1%-Accurate Signal Conditioner for Piezoresistive Sensor Compensation

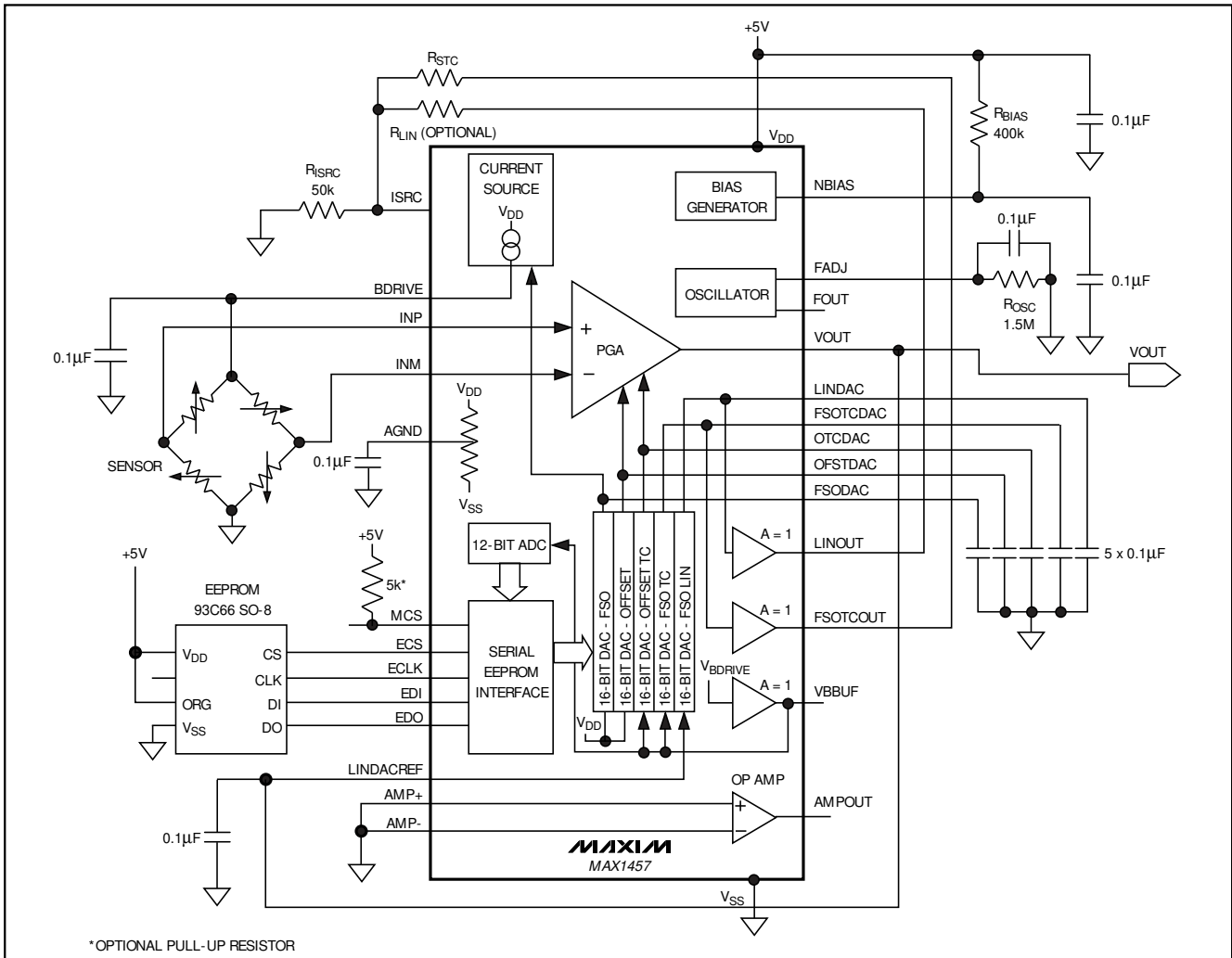

Figure 5. Basic Ratiometric Output Configuration

## Sensor Compensation Overview

Compensation requires an examination of the sensor performance over the operating pressure and temperature range. Use two test pressures (e.g., zero and full-span) and two temperatures. More test pressures and temperatures will result in greater accuracy. A simple compensation procedure can be summarized as follows:

### Set reference temperature (e.g., +25°C):

- 1) Initialize each transducer by loading its EEPROM with default coefficients (e.g., based on mean values of offset, FSO, and bridge resistance) to prevent gross overload of the MAX1457.
- 2) Set the initial bridge voltage (with the FSO DAC) to half the supply voltage. The bridge voltage can be

measured by the MAX1457 and returned to the test computer via the serial interface or by using the system digital voltmeter to measure the voltage on either BDRIVE or VBBUF.

- 3) Calibrate the transducer's output offset and FSO using the OFFSET and FSO DACs, respectively.
- 4) Store calibration data in the test computer.

### Set next test temperature:

- 5) Calibrate offset and FSO using the OFFSET TC and FSO TC DACs, respectively.
- 6) Store calibration data in the test computer.

**Repeat steps 5 and 6 for each required test temperature.**



# 0.1%-Accurate Signal Conditioner for Piezoresistive Sensor Compensation

MAX1457

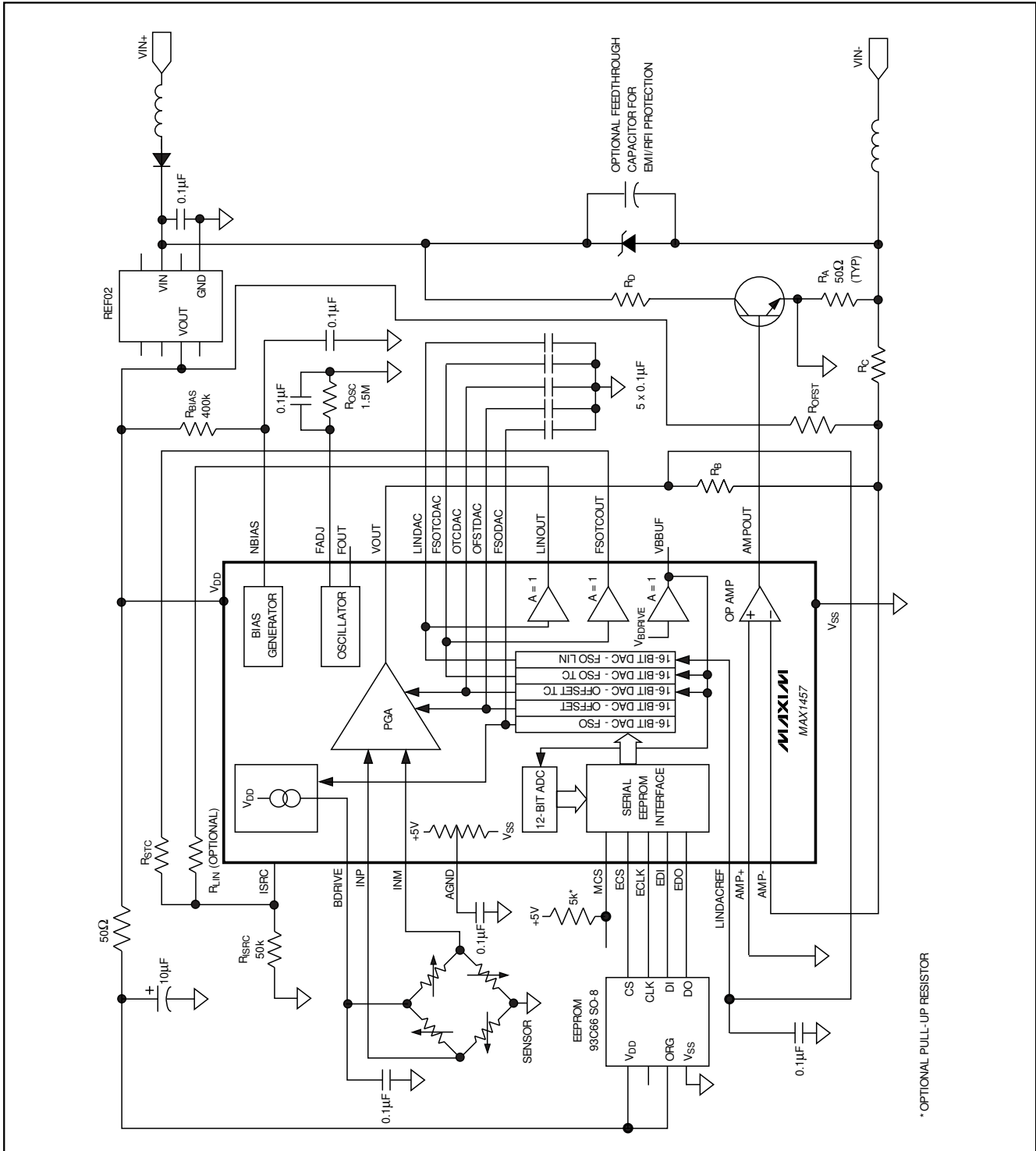

Figure 6. Basic 2-Wire 4-20mA Configuration

# 0.1%-Accurate Signal Conditioner for Piezoresistive Sensor Compensation

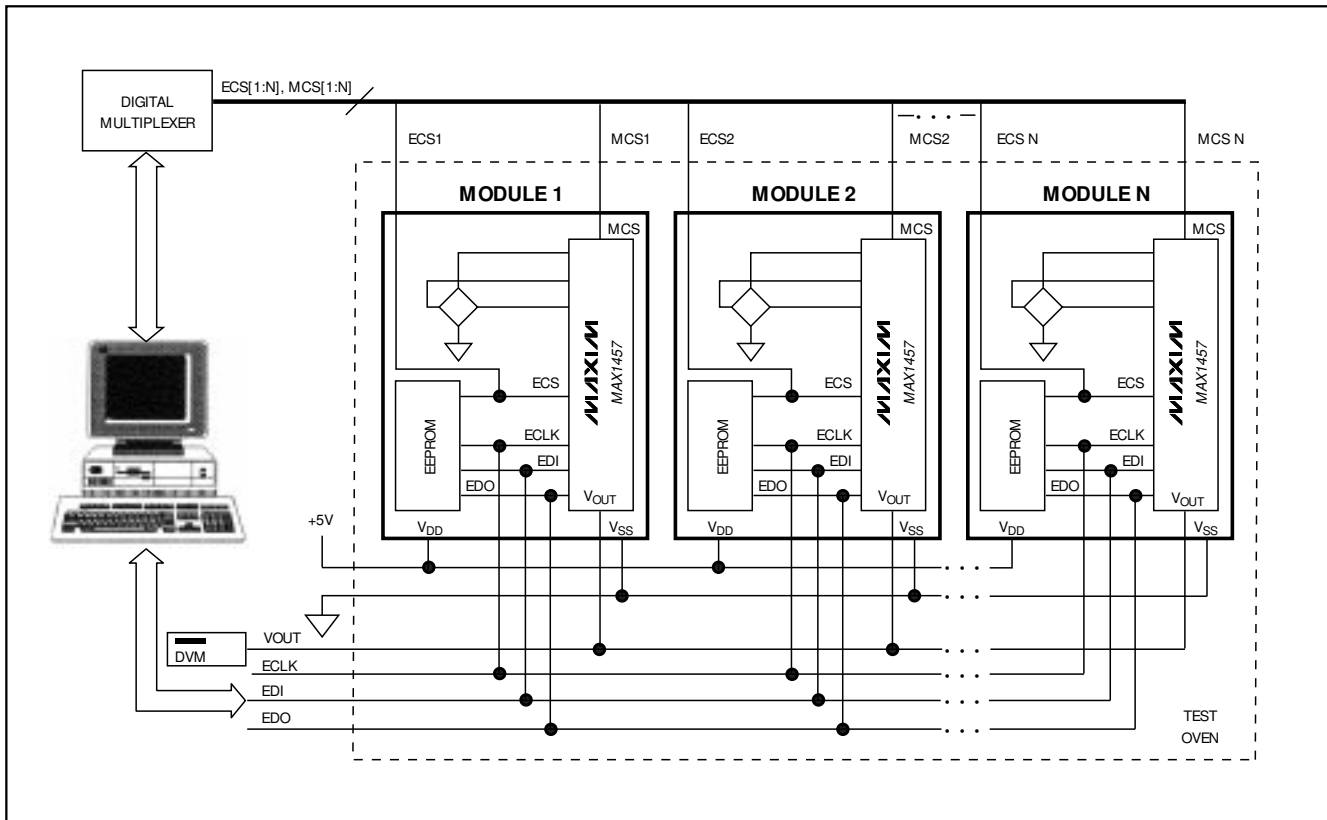

Figure 7. Automated Test System Concept

- 7) Perform curve-fitting to test data.
- 8) Based on a curve-fit algorithm, calculate up to 120 sets of offset and FSO correcting values.
- 9) Download correction coefficients to transducer EEPROM.
- 10) Perform a final test.

The resulting transducer temperature errors are limited by the following factors:

- Number of selected segments for compensation (up to 120).
- Accuracy of the curve fitting, which depends on the algorithm used, the number of test temperatures, and the sensor temperature error's shape.
- Repeatability of the sensor performance. This will limit the MAX1457's accuracy.

## Sensor Calibration and Compensation Example

Calibration and compensation requirements for a sensor involve conversion of the sensor-specific performance into a normalized output curve. An example of the MAX1457's capabilities is shown in Table 1.

As shown in Table 1, a repeatable piezoresistive sensor with an initial offset of 16.4mV and FSO of 55.8mV was converted into a compensated transducer (utilizing the piezoresistive sensor with the MAX1457) with an offset of 0.500V and a span of 4.000V. Nonlinear sensor offset and FSO temperature errors, which were on the order of 4% to 5% FSO, were reduced to under  $\pm 0.1\%$  FSO. The graphs in Figure 8 show the output of the uncompensated sensor and the output of the compensated transducer.

# 0.1%-Accurate Signal Conditioner for Piezoresistive Sensor Compensation

**Table 1. MAX1457 Sensor Calibration and Compensation**

Typical Uncompensated Input (Sensor)	Typical Compensated Transducer Output
Offset . . . . . $\pm 100\%$ FSO	Temperature Range . . . . . $-40^{\circ}\text{C}$ to $+125^{\circ}\text{C}$
FSO . . . . . $.20\text{mV/V}$ to $30\text{mV/V}$	$V_{\text{OUT}}$ . . . . . ratiometric to $V_{\text{DD}}$ at $5.0\text{V}$
Offset TC . . . . . $.20\%$ FSO	Offset at $+25^{\circ}\text{C}$ . . . . . $0.500\text{V} \pm 200\mu\text{V}$
Offset TC Nonlinearity . . . . . $.4\%$ FSO	FSO at $+25^{\circ}\text{C}$ . . . . . $.4.000\text{V} \pm 200\mu\text{V}$
FSO TC . . . . . $-.20\%$ FSO	Offset Accuracy Over Temperature Range . . . . . $\pm 4\text{mV}$ ( $0.1\%$ FSO)
FSO TC Nonlinearity . . . . . $.5\%$ FSO	FSO Accuracy Over Temperature Range . . . . . $\pm 4\text{mV}$ ( $0.1\%$ FSO)

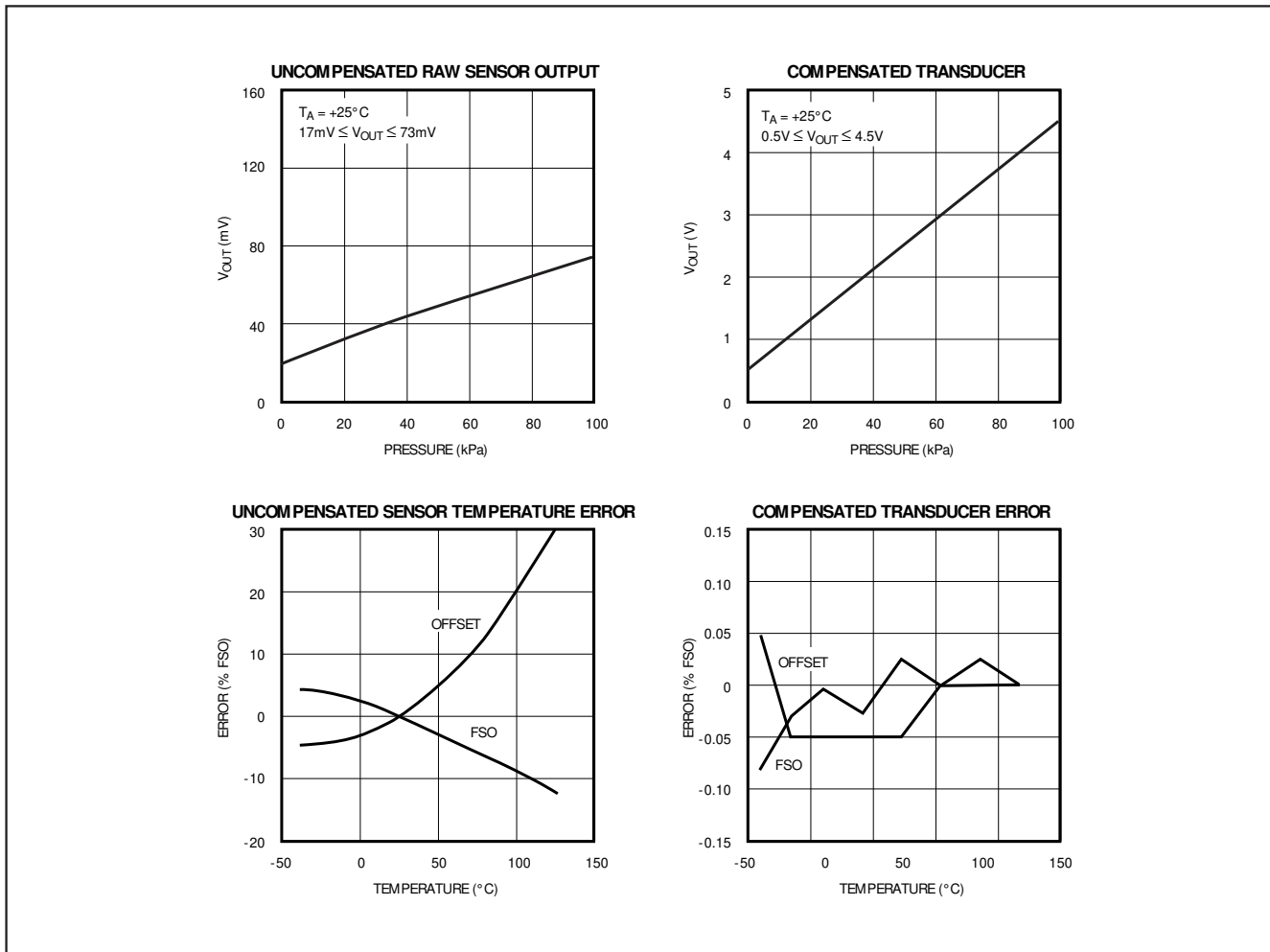

Figure 8. Comparison of an Uncompensated Sensor (left) and a Compensated Transducer (right)

# 0.1%-Accurate Signal Conditioner for Piezoresistive Sensor Compensation

## MAX1457 Evaluation Development Kit

To expedite the development of MAX1457-based transducers and test systems, Maxim has produced a MAX1457 evaluation kit (EV kit). First-time users of the MAX1457 are strongly encouraged to use this kit.

The kit is designed to facilitate manual programming of the MAX1457 with a sensor. It includes the following:

- 1) Evaluation board (EV board) with a silicon pressure sensor, ready for customer evaluation.
- 2) Design/applications manual, which describes in detail the architecture and functionality of the MAX1457. This manual was developed for test engineers familiar with data acquisition of sensor data and provides sensor-compensation algorithms and test procedures.
- 3) MAX1457 communication software, which enables programming of the MAX1457 from a computer keyboard (IBM compatible), one module at a time.
- 4) Interface adapter and cable, which allows the connection of the EV board to a PC parallel port.

## Chip Information

TRANSISTOR COUNT: 17534

SUBSTRATE CONNECTED TO V<sub>SS</sub>

## Ordering Information (continued)

PART	TEMP. RANGE	PIN-PACKAGE
MAX1457AWI	-40°C to +125°C	28 Wide SO
MAX1457ACJ	-40°C to +125°C	32 TQFP

## Pin Configurations

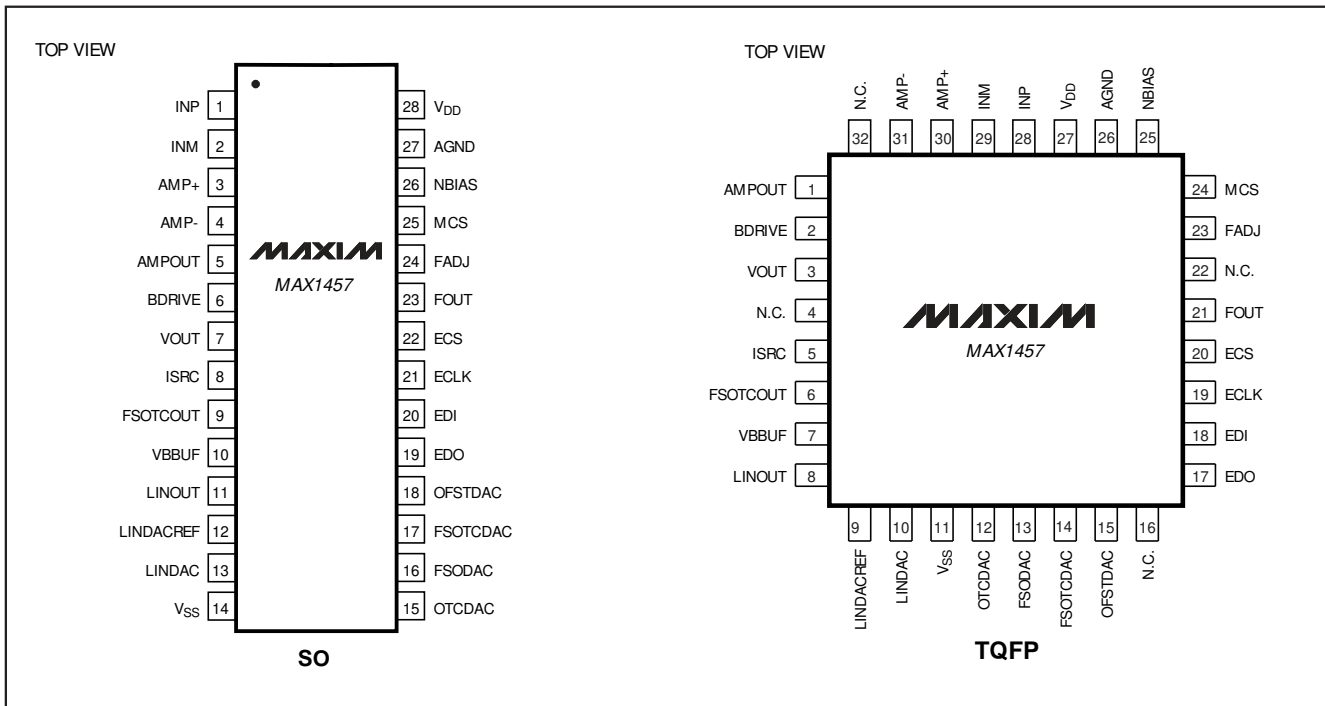

Maxim cannot assume responsibility for use of any circuitry other than circuitry entirely embodied in a Maxim product. No circuit patent licenses are implied. Maxim reserves the right to change the circuitry and specifications without notice at any time.

12 Maxim Integrated Products, 120 San Gabriel Drive, Sunnyvale, CA 94086 408-737-7600