

used for: D-SUB HD

Part NO.	POS.	A -0.76	B -0.25	C
164A17109X	15	31.19	16.46	25.00 ^{+0.12} / _{-0.13}
164A17119X	26	39.52	24.79	33.30 ^{+0.15} / _{-0.1}
164A17129X	44	53.42	38.50	47.04 ±0.13
164A17139X	62	69.70	54.96	63.50 ±0.13

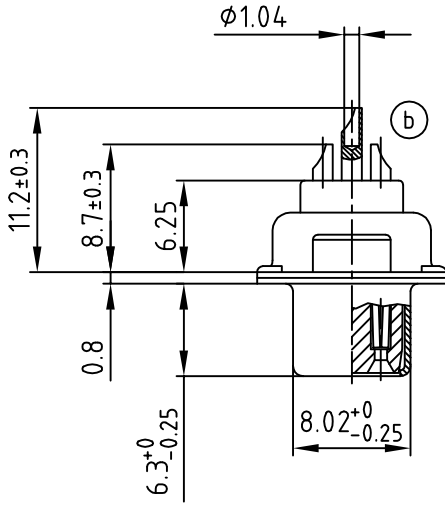
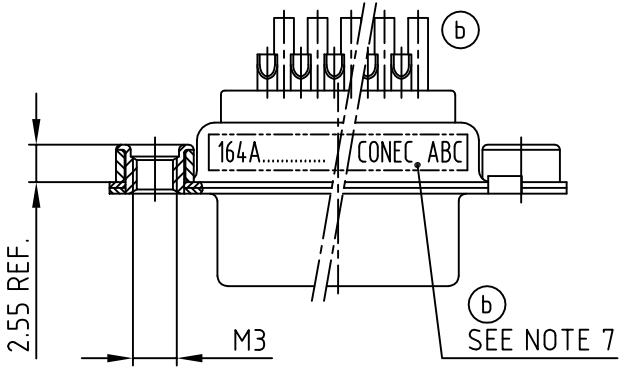
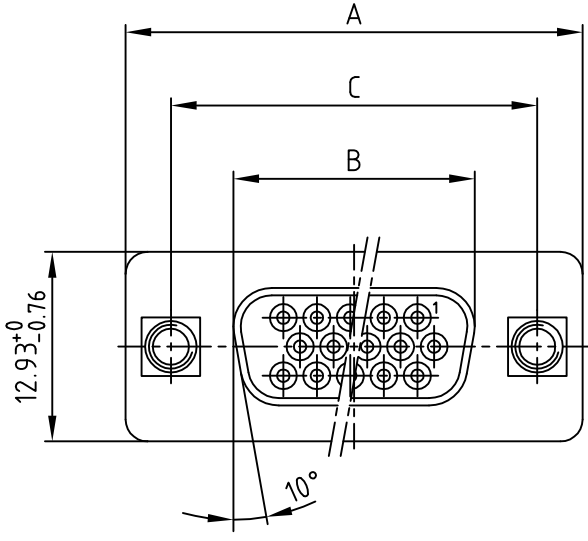

NOTES:

- METALSHELLS: STEEL; min. 315µin TIN over 40-80µin NICKEL
- INSULATORS: PBT GF UL 94 V-0, BLACK
- CONTACTS: COPPER ALLOY
PLATING: GOLD FLASH over NICKEL
SOLDER CUP ACCEPTS CABLE AWG 22
- THREADED INSERT: COPPER ALLOY; min. 200µin TIN over 80µin NICKEL
- COLLAR: COPPER ALLOY; min. 200µin TIN over 80µin NICKEL
- MAXIMUM TORQUE VALUE FOR THREAD: 6 in.LB
- CONNECTOR IS PART MARKED: PART-NO. CONEC ABC

Directive 2002/95/EC RoHS compliant

APPROVAL # FREIGABE # DEBLOCAGE # AUTORIZACION # APPROVAL	
CUSTOMER APPROVAL DATE:	
NAME:	TITLE:
COMPANY NAME:	
APPROVAL # FREIGABE # DEBLOCAGE # AUTORIZACION # APPROVAL	

THIS DRAWING MAY NOT BE COPIED OR REPRODUCED IN ANY WAY, AND MAY NOT BE PASSED ON TO A THIRD PARTY WITHOUT WRITTEN PERMISSION.
 OWNERSHIP AND COPYRIGHT OF CONEC GmbH
 DO NOT ALTER CAD DRAWING BY HAND

tolerance		dim. in mm	
2001	date	name	
drawn	04.10.	Parei	
appd.	04.10.	E. Mickenbecker	
norm			
d-old			
3 x b	Ä 3143	14.10.2008	Lehmen.
a	Origin		
rev.	description	date	name



scale:	2:1	
material:	SEE NOTES	
title:	D-SUB HD FEMALE 15-62pos. SOLDER CUP with threaded insert	
dwg no:	AutoCAD 2006	DIN-A
	16K1A323A	4
part no:	SEE TABLE	
		sh: 1/1