

STRAIGHT PLUG CRIMP TYPE

R223.083.000

CABLE 2.6/50 D

Series : MMBX

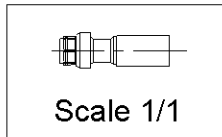
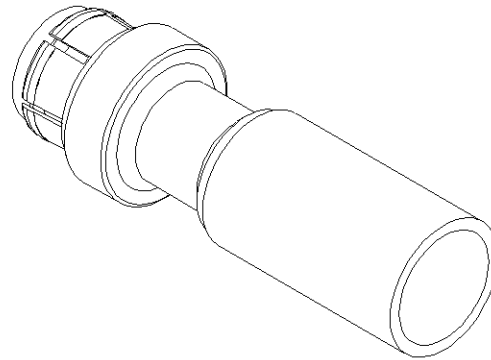
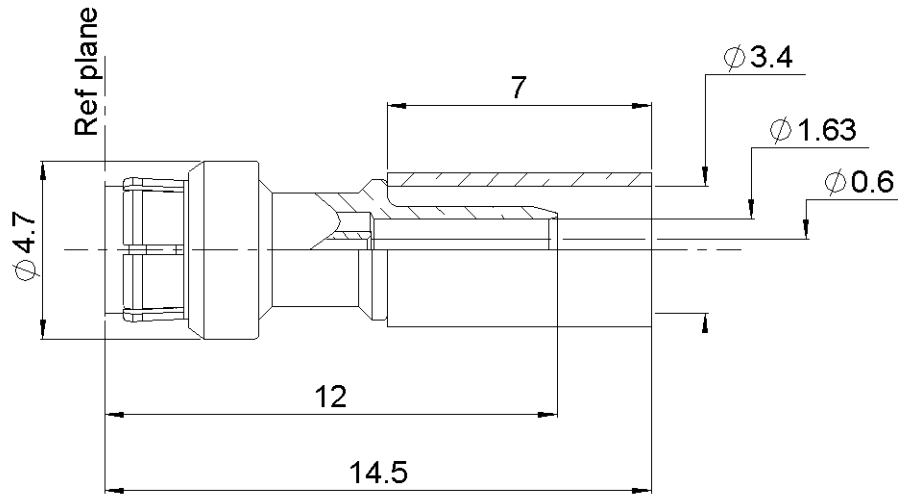

All dimensions are in mm.

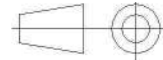

COMPONENTS	MATERIALS	PLATING (μm)
BODY	BRASS	NPGR
CENTER CONTACT	BERYLLIUM COPPER; BRASS	NPGR
OUTER CONTACT	BERYLLIUM COPPER	NPGR
INSULATOR	PTFE	
GASKET		
OTHERS PARTS		
-	-	-
-	-	-

Issue : 0735 B

In the effort to improve our products, we reserve the right to make changes judged to be necessary.



STRAIGHT PLUG CRIMP TYPE

R223.083.000

CABLE 2.6/50 D

Series : MMBX

PACKAGING

Standard	Unit	Other
100	'W' option	Contact us

SPECIFICATION

ELECTRICAL CHARACTERISTICS

Impedance		50 Ω
Frequency		0-12.4 GHz
VSWR	1.11 +	0,0000 x F(GHz) Maxi
Insertion loss		0.12 √F(GHz) dB Maxi
RF leakage	- (100 - F(GHz)) dB Maxi
Voltage rating		250 Veff Maxi
Dielectric withstanding voltage		750 Veff mini
Insulation resistance		1000 MΩ mini

CABLE ASSEMBLY

Stripping	a	b	c	d	e	f
mm	1,50	4,50	6,50	0,00	5,00	0,00

Assembly instruction : **Crimp 02**

Recommended cable(s)
K02252D

Characteristics indicated on this data sheet are those that can be achieved with the highest performance cable. Intrinsic limitations of the cable may diminish the performance of the assembly

Cable retention

- pull off **110** N mini
- torque **NA** N.cm

MECHANICAL CHARACTERISTICS

Center contact retention		
Axial force – Mating end	10	N mini
Axial force – Opposite end	10	N mini
Torque		N.cm mini

Recommended torque		
Mating	NA	N.cm
Panel nut	NA	N.cm
Clamp nut	NA	N.cm
A/F clamp nut	0,0000	mm

Mating life	100	Cycles mini
Weight	0,7700	g

TOOLING

Part Number	Description	Hexagon
.	.	.
R282.235.906	CRIMPING DIES	3.3 square 0.7
R282.293.000	CRIMPING TOOL M22520/5-01	

OTHER CHARACTERISTICS

to 6 GHz
Interface MMBX only up to 2.5 GHz

ENVIRONMENTAL

Operating temperature	-55/155	° C
Hermetic seal	NA	Atm.cm3/s
Panel leakage	NA	

Issue : 0735 B

In the effort to improve our products, we reserve the right to make changes judged to be necessary.

