



FAST CMOS 16-BIT BIDIRECTIONAL TRANSCEIVER

IDT54/74FCT162245T/AT/CT

FEATURES:

- 0.5 MICRON CMOS Technology
- High-speed, low-power CMOS replacement for ABT functions
- Typical $t_{sk(o)}$ (Output Skew) < 250ps
- Low input and output leakage $\leq 1\mu A$ (max.)
- ESD > 2000V per MIL-STD-883, Method 3015; > 200V using machine model (C = 200pF, R = 0)
- **Balanced Output Drivers:**
 - $\pm 24mA$ (industrial)
 - $\pm 16mA$ (military)
- Reduced system switching noise
- Typical VOLP (Output Ground Bounce) < 0.6V at $V_{cc} = 5V$, $T_A = 25^\circ C$
- Available in the following packages:
 - Industrial: SSOP, TSSOP
 - Military: CERPACK

DESCRIPTION:

The FCT162245T 16-bit transceiver is built using advanced dual metal CMOS technology. These high-speed, low-power transceivers are ideal for synchronous communication between two buses (A and B). The Direction and Output Enable controls operate these devices as either two independent 8-bit transceivers or one 16-bit transceiver. The direction control pin ($xDIR$) controls the direction of data flow. The output enable pin ($x\overline{OE}$) overrides the direction control and disables both ports. All inputs are designed with hysteresis for improved noise margin.

The FCT162245T has balanced output drive with current limiting resistors. This offers low ground bounce, minimal undershoot, and controlled output fall times—reducing the need for external series terminating resistors. The FCT162245T is a plug-in replacement for the FCT16245T and ABT16245 for on-board interface applications.

FUNCTIONAL BLOCK DIAGRAM

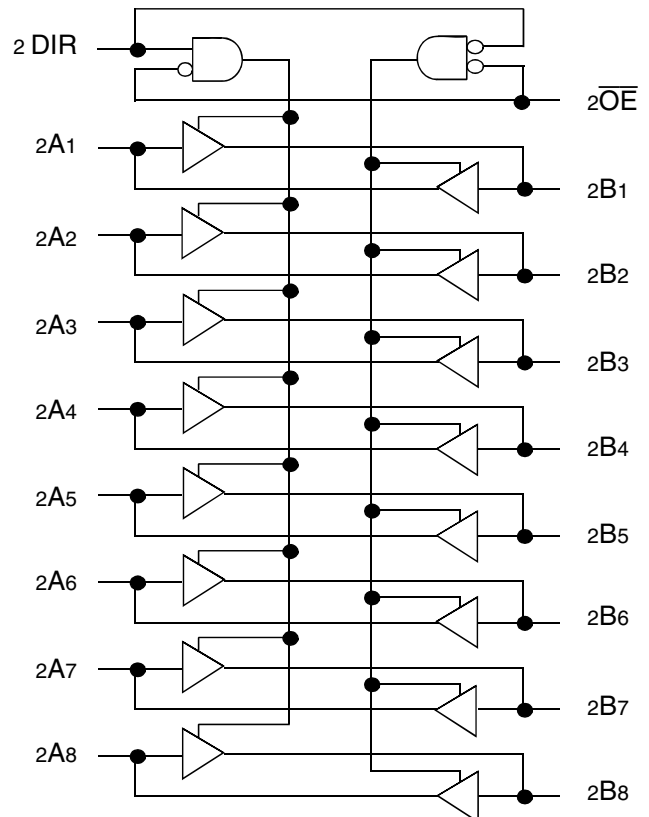
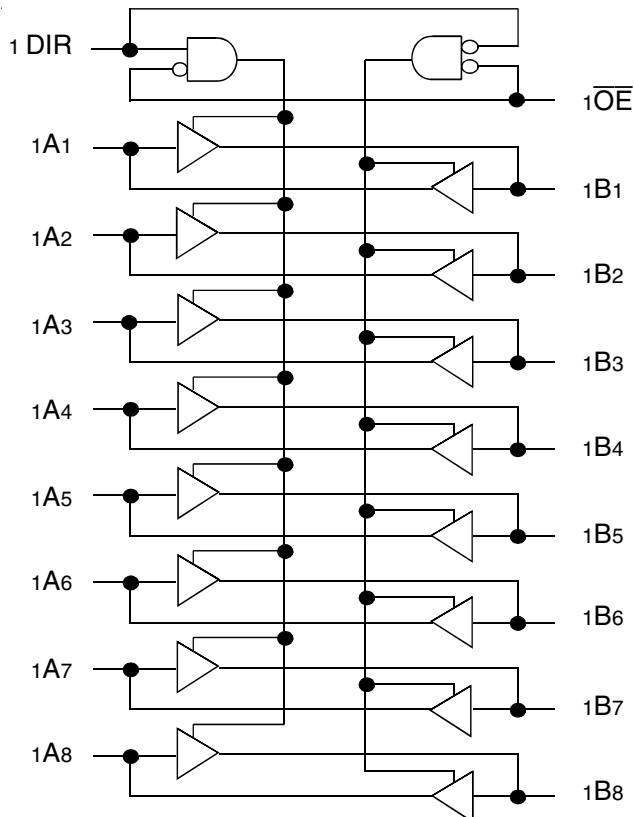

The IDT logo is a registered trademark of Integrated Device Technology, Inc.

MILITARY AND INDUSTRIAL TEMPERATURE RANGES

OCTOBER 2008

PIN CONFIGURATION

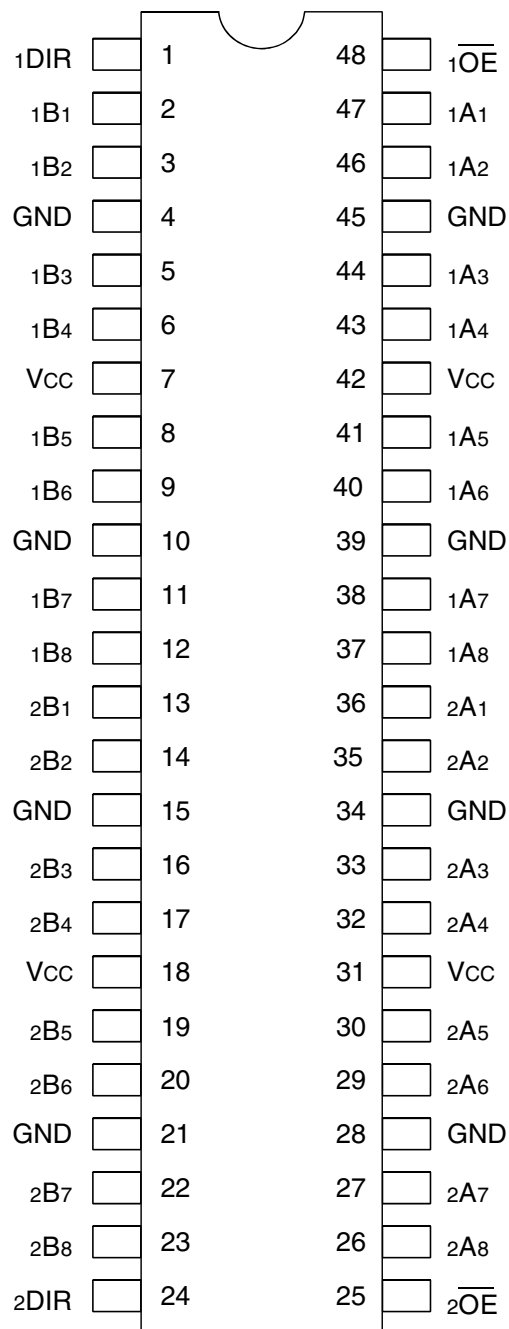

SSOP/ TSSOP/ CERPACK
TOP VIEW

ABSOLUTE MAXIMUM RATINGS⁽¹⁾

Symbol	Description	Max	Unit
V _{TERM} ⁽²⁾	Terminal Voltage with Respect to GND	-0.5 to +7	V
V _{TERM} ⁽³⁾	Terminal Voltage with Respect to GND	-0.5 to V _{CC} +0.5	V
T _{STG}	Storage Temperature	-65 to +150	°C
I _{OUT}	DC Output Current	-60 to +120	mA

NOTES:

- Stresses greater than those listed under ABSOLUTE MAXIMUM RATINGS may cause permanent damage to the device. This is a stress rating only and functional operation of the device at these or any other conditions above those indicated in the operational sections of this specification is not implied. Exposure to absolute maximum rating conditions for extended periods may affect reliability.
- All device terminals except FCT162XXXT AND FCT166XXXT (A-Port) Output and I/O terminals.
- Output and I/O terminals terminals for FCT162XXXT AND FCT166XXXT (A-Port).

CAPACITANCE (T_A = +25°C, F = 1.0MHz)

Symbol	Parameter ⁽¹⁾	Conditions	Typ.	Max.	Unit
C _{IN}	Input Capacitance	V _{IN} = 0V	3.5	6	pF
C _{OUT}	Output Capacitance	V _{OUT} = 0V	3.5	8	pF

NOTE:

- This parameter is measured at characterization but not tested.

PIN DESCRIPTION

Pin Names	Description
x \overline{OE}	Output Enable Inputs (Active LOW)
xDIR	Direction Control Input
xAx	Side A Inputs or 3-State Outputs
xBx	Side B Inputs or 3-State Outputs

FUNCTION TABLE⁽¹⁾

Inputs		Outputs
x \overline{OE}	xDIR	
L	L	Bus B Data to Bus A
L	H	Bus A Data to Bus B
H	X	High Z State

NOTE:

- H = HIGH Voltage Level
L = LOW Voltage Level
X = Don't Care
Z = High-Impedance

DC ELECTRICAL CHARACTERISTICS OVER OPERATING RANGE

Following Conditions Apply Unless Otherwise Specified:

Industrial: TA = -40°C to +85°C, VCC = 5.0V ±10%; Military: TA = -55°C to +125°C, VCC = 5.0V ±10%

Symbol	Parameter	Test Conditions ⁽¹⁾		Min.	Typ. ⁽²⁾	Max.	Unit
V _{IH}	Input HIGH Level	Guaranteed Logic HIGH Level		2	—	—	V
V _{IL}	Input LOW Level	Guaranteed Logic LOW Level		—	—	0.8	V
I _{IH}	Input HIGH Current (Input pins) ⁽⁵⁾	V _{CC} = Max.	V _I = V _{CC}	—	—	±1	μA
	Input HIGH Current (I/O pins) ⁽⁵⁾			—	—	±1	
I _{IL}	Input LOW Current (Input pins) ⁽⁵⁾		V _I = GND	—	—	±1	
	Input LOW Current (I/O pins) ⁽⁵⁾			—	—	±1	
I _{OZH}	High Impedance Output Current (3-State Output pins) ⁽⁵⁾	V _{CC} = Max.	V _O = 2.7V	—	—	±1	μA
I _{OZL}			V _O = 0.5V	—	—	±1	
V _{IK}	Clamp Diode Voltage	V _{CC} = Min., I _{IN} = -18mA		—	-0.7	-1.2	V
I _{OS}	Short Circuit Current	V _{CC} = Max., V _O = GND ⁽³⁾		-80	-140	-250	mA
V _H	Input Hysteresis	—		—	100	—	mV
I _{CCL} I _{CCH} I _{CCZ}	Quiescent Power Supply Current	V _{CC} = Max. V _{IN} = GND or V _{CC}		—	5	500	μA

OUTPUT DRIVE CHARACTERISTICS

Symbol	Parameter	Test Conditions ⁽¹⁾		Min.	Typ. ⁽²⁾	Max.	Unit
I _{ODL}	Output LOW Current	V _{CC} = 5V, V _{IN} = V _{IH} or V _{IL} , V _O = 1.5V ⁽³⁾		60	115	200	mA
I _{ODH}	Output HIGH Current	V _{CC} = 5V, V _{IN} = V _{IH} or V _{IL} , V _O = 1.5V ⁽³⁾		-60	-115	-200	mA
V _{OH}	Output HIGH Voltage	V _{CC} = Min V _{IN} = V _{IH} or V _{IL}	I _{OH} = -16mA MIL I _{OH} = -24mA IND	2.4	3.3	—	V
V _{OL}	Output LOW Voltage	V _{CC} = Min V _{IN} = V _{IH} or V _{IL}	I _{OH} = 16mA MIL I _{OH} = 24mA IND	—	0.3	0.55	V

NOTES:

- For conditions shown as Min. or Max., use appropriate value specified under Electrical Characteristics for the applicable device type.
- Typical values are at V_{CC} = 5.0V, +25°C ambient.
- Not more than one output should be tested at one time. Duration of the test should not exceed one second.
- Duration of the condition can not exceed one second.
- This test limit for this parameter is ±5μA at TA = -55°C.

POWER SUPPLY CHARACTERISTICS

Symbol	Parameter	Test Conditions ⁽¹⁾		Min.	Typ. ⁽²⁾	Max.	Unit
ΔI_{CC}	Quiescent Power Supply Current TTL Inputs HIGH	$V_{CC} = \text{Max.}$ $V_{IN} = 3.4V^{(3)}$		—	0.5	1.5	mA
I_{CCD}	Dynamic Power Supply Current ⁽⁴⁾	$V_{CC} = \text{Max.}$ Outputs Open $\overline{xOE} = xDIR = GND$ One Input Toggling 50% Duty Cycle	$V_{IN} = V_{CC}$ $V_{IN} = GND$	—	60	100	$\mu A /$ MHz
I_C	Total Power Supply Current ⁽⁶⁾	$V_{CC} = \text{Max.}$ Outputs Open $f_i = 10\text{MHz}$ 50% Duty Cycle $\overline{xOE} = xDIR = GND$ One Bits Toggling	$V_{IN} = V_{CC}$ $V_{IN} = GND$	—	0.6	1.5	mA
			$V_{IN} = 3.4V$ $V_{IN} = GND$	—	0.9	2.3	
		$V_{CC} = \text{Max.}$ Outputs Open $f_i = 2.5\text{MHz}$ 50% Duty Cycle $\overline{xOE} = xDIR = GND$ Sixteen Bits Toggling	$V_{IN} = V_{CC}$ $V_{IN} = GND$	—	2.4	4.5 ⁽⁵⁾	
			$V_{IN} = 3.4V$ $V_{IN} = GND$	—	6.4	16.5 ⁽⁵⁾	

NOTES:

- For conditions shown as Min. or Max., use appropriate value specified under Electrical Characteristics for the applicable device type.
- Typical values are at $V_{CC} = 5.0V$, $+25^\circ C$ ambient.
- Per TTL driven input ($V_{IN} = 3.4V$). All other inputs at V_{CC} or GND.
- This parameter is not directly testable, but is derived for use in Total Power Supply Calculations.
- Values for these conditions are examples of the I_{CC} formula. These limits are guaranteed but not tested.
- $I_C = I_{QUIESCENT} + I_{INPUTS} + I_{DYNAMIC}$
 $I_C = I_{CC} + \Delta I_{CC} \cdot DH \cdot NT + I_{CCD} (f_{CP} \cdot N_{CP} / 2 + f_i \cdot N_i)$
 $I_{CC} = \text{Quiescent Current (} I_{CCL}, I_{CCH} \text{ and } I_{CCZ})$
 $\Delta I_{CC} = \text{Power Supply Current for a TTL High Input (} V_{IN} = 3.4V)$
 $DH = \text{Duty Cycle for TTL Inputs High}$
 $NT = \text{Number of TTL Inputs at } DH$
 $I_{CCD} = \text{Dynamic Current caused by an Input Transition Pair (HLH or LHL)}$
 $f_{CP} = \text{Clock Frequency for Register Devices (Zero for Non-Register Devices)}$
 $N_{CP} = \text{Number of Clock Inputs at } f_{CP}$
 $f_i = \text{Input Frequency}$
 $N_i = \text{Number of Inputs at } f_i$

SWITCHING CHARACTERISTICS OVER OPERATING RANGE

Symbol	Parameter	Condition ⁽¹⁾	54FCT162445T		54/74FCT162245AT				54/74FCT162245CT				Unit
			Mil.		Ind.		Mil.		Ind.		Mil.		
			Min. ⁽²⁾	Max.	Min. ⁽²⁾	Max.	Min. ⁽²⁾	Max.	Min. ⁽²⁾	Max.	Min. ⁽²⁾	Max.	
t_{PLH}	Propagation Delay	$C_L = 50pF$ $R_L = 500\Omega$	1.5	7.5	1.5	4.6	1.5	4.9	1.5	3.5	1.5	4.5	ns
t_{PHL}	A to B, B to A												
t_{PZH}	Output Enable Time		1.5	10	1.5	6.2	1.5	6.5	1.5	4.4	1.5	6.2	ns
t_{PZL}	\overline{xOE} to A or B												
t_{PHZ}	Output Disable Time		1.5	10	1.5	5	1.5	6	1.5	4	1.5	5.2	ns
t_{PLZ}	\overline{xOE} to A or B												
t_{PZH}	Output Enable Time		1.5	10	1.5	6.2	1.5	6.5	1.5	4.8	1.5	6.2	ns
t_{PZL}	$xDIR$ to A or B ⁽⁴⁾												
t_{PHZ}	Output Disable Time	1.5	10	1.5	5	1.5	6	1.5	4	1.5	5.2	ns	
t_{PLZ}	$xDIR$ to A or B ⁽⁴⁾												
$t_{SK(o)}$	Output Skew ⁽³⁾		—	0.5	—	0.5	—	0.5	—	0.5	—	0.5	ns

NOTES:

- See test circuit and waveforms.
- Minimum limits are guaranteed but not tested on Propagation Delays.
- Skew between any two outputs of the same package switching in the same direction. This parameter is guaranteed by design.
- This parameter is guaranteed but not tested.

TEST CIRCUITS AND WAVEFORMS

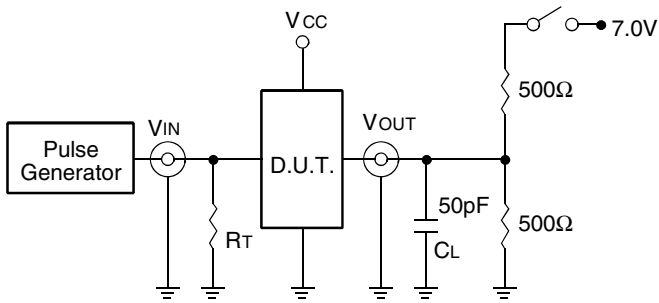

Test Circuits for All Waveforms

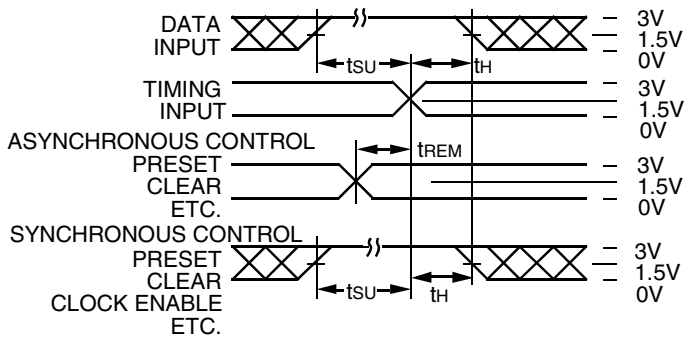

Set-up, Hold, and Release Times

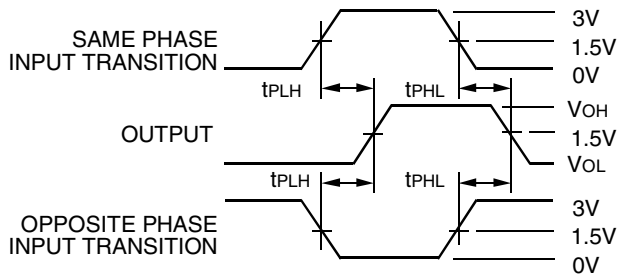

Propagation Delay

SWITCH POSITION

Test	Switch
Open Drain Disable Low Enable Low	Closed
All Other Tests	Open

DEFINITIONS:

CL = Load capacitance: includes jig and probe capacitance.
RT = Termination resistance: should be equal to Zout of the Pulse Generator.

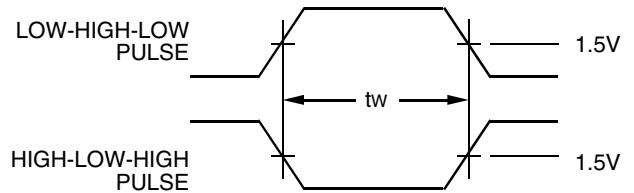

Pulse Width

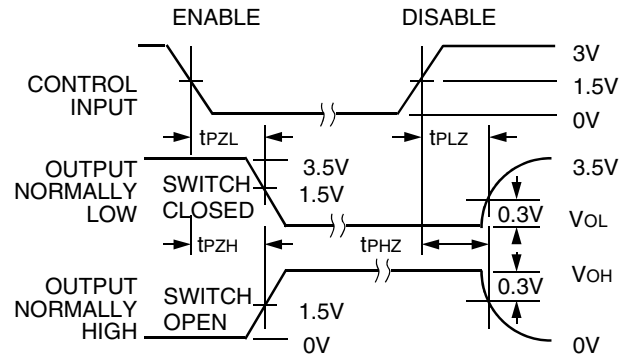

Enable and Disable Times

NOTES:

- Diagram shown for input Control Enable-LOW and input Control Disable-HIGH.
- Pulse Generator for All Pulses: Rate $\leq 1.0\text{MHz}$; $t_r \leq 2.5\text{ns}$; $t_n \leq 2.5\text{ns}$.

ORDERING INFORMATION

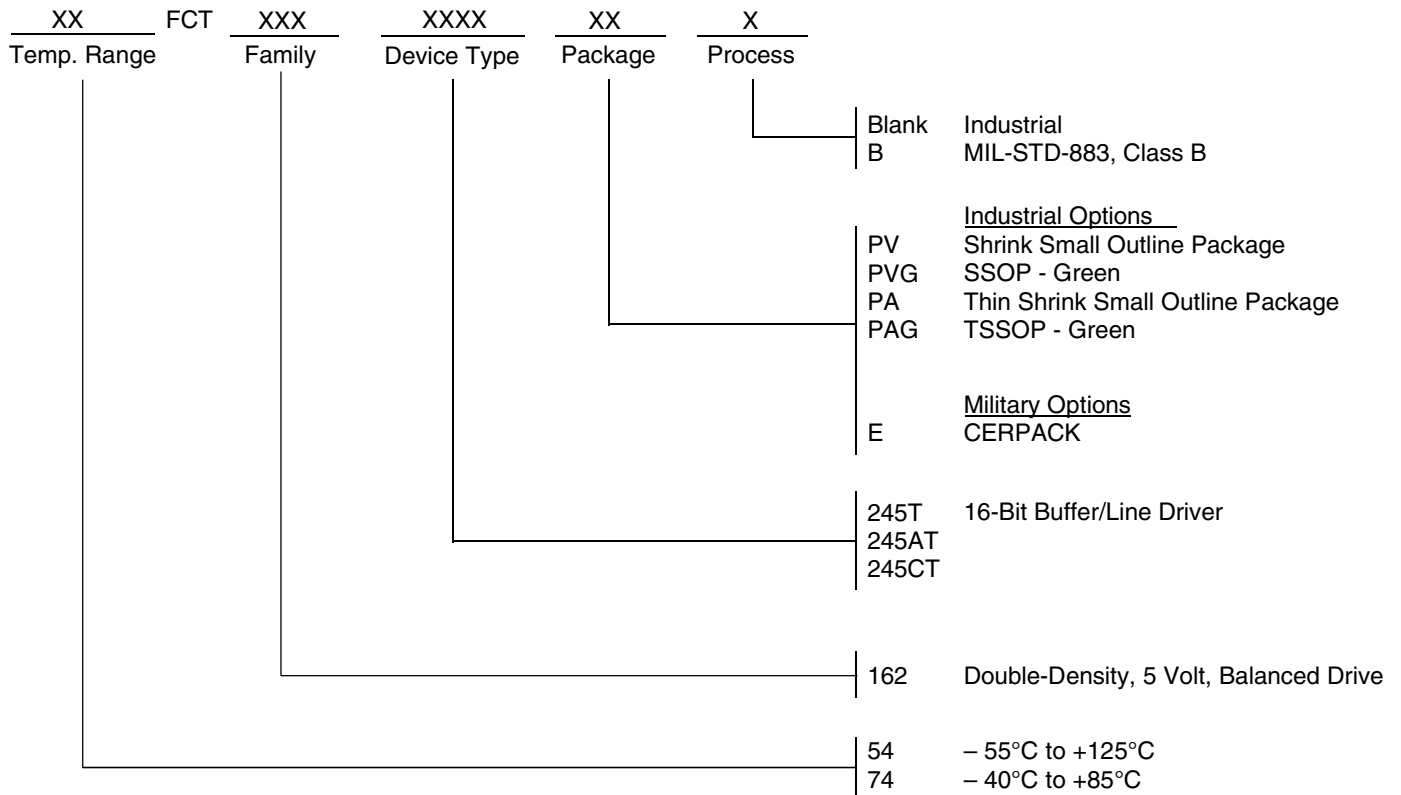

CORPORATE HEADQUARTERS
 6024 Silver Creek Valley Road
 San Jose, CA 95138

for SALES:
 800-345-7015 or 408-284-8200
 fax: 408-284-2775
 www.idt.com

for Tech Support:
 logichelp@idt.com