



SPECIFICATION FOR PIEZO ELECTRIC BUZZER

TOTAL PAGE	06	www.bestarsensor.com	RoHS
------------	----	--	------

Customer		Model Name	FT-23G-3.5A1-W035
Customer P/N		Product No.	
Date	9 Jan. 13	Issue No.	BS/TEY01.453D
Page	01 of 06	Issue Date	17/07/11

Approval:

- 1.Electrical characteristics
- 2.Dimension
- 3.Characteristics
- 4.Measuring Method
- 5.Reliability Test
- 6.Packing
- 7.History Change Record

Drawn by	Checked by	Approved by	Customer approved

BESTAR SENSORTECH CO.,LTD

Room 706.No.178. YuLong South Road,Zhonglou district,ChangZhou,
JiangSuProvince,P.R.China

Tel: +86 519 88990131 **Fax:** +86 519 88990133

E-mail:li@bestarsensor.com **<http://www.bestarsensor.com>**

文件号: BS/QDTE045B

FT-23G-3.5A1-W035

1. Electrical characteristics

1.	Resonant Frequency	3.5±0.5 KHz
2.	Resonant Impedance	1500 ohm Max
3.	Capacitance at 120Hz	18±30% nF
4.	Insulation resistance	100M ohm Min
5.	Input Voltage	30 Vp-p
6.	Operating Temperature	-20...+70°C
7.	Storage Temperature	-30...+80 °C
8.	Metal Material	SUS316L

2. Drawing

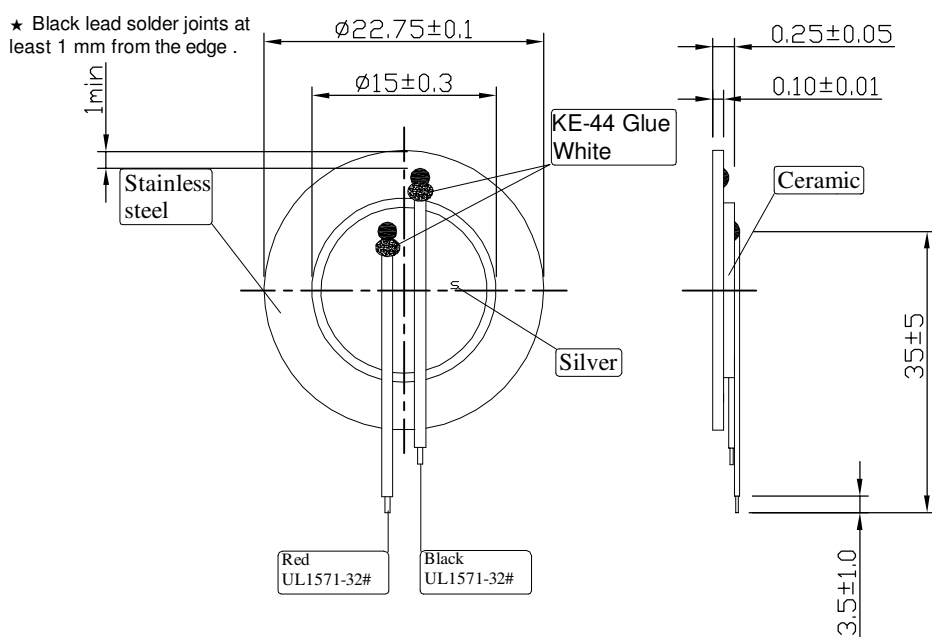

Unit:mm

D	17/07/11	Li u Ruf eng	Change Metal Material	Date:	14/01/09	FT-23G-3.5A1-W035	
C	15/03/05	Li u Ruf eng	Change Glue	Drawn by:	Ma Guoyang		
B	14/11/20	Li u Ruf eng	Add Packaging	Checked by:	M chael	Piezo Ceramic Element	
Rev.	Date	Drawn	Note	Approved by:	Li Hngyuan		
BESTAR SENSORTECH CO.,LTD						DRG NO: BS/TEY01.453C	Page:02 of 06
www.bestarsensor.com li@bestarsensor.com							

FT-23G-3.5A1-W035

3.Characteristics:

3.1 Solderability

Solder AWG 30 wire with solder wire(SnAgCu) at $300\pm 10^{\circ}\text{C}$ on the ceramic , less than 2 seconds duration of soldering.

3.2 Lead pull off test

a) Wire to be soldered on ceramic at the edge. It should withstand minimum 20N force applied in 180° .The wire should not come out before this .The ceramic can be either glued on a surface of can be held in hand.(Fig.3.2)

b) Wire to be soldered on ceramic at the edge&should be pulled up at 90° The element should be hold on bottom and wire should be pulled up .It should withstand at least for 2.8N force(Fig.3.1)

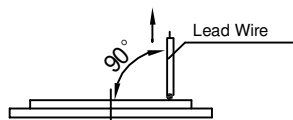

Fig.3.1 Direction of Lead Wire

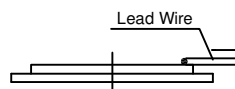

Fig.3.2 Direction of Lead Wire

4.Measuring Method

4.1.Resonant Frequency/ Resonant Impedance:

Piezoelectric disc shall be clamped at a node or edge point ,figure to be free from any mechanical stresses,and measure its resonant frequency and resonant impedance by using vector impedance analyzer or equivalent.

Input frequency shall be swept within 1 to 5 kHz, where the resonant frequency is defined and the frequency

where the impedance shows minimum value, this impedance shall be the resonant impedance.

4.2.Capacitance:

A electrostatic capacity capacitance shall be measured at 120Hz by using LCR meter, such as DF2812A LCR number bridge or equivalent. The part shall be clamped in the same way as the measurement of resonant frequency / resonant impedance mentioned in section 4.1.

4.3.Insulation Resistance:

An insulation resistance shall be measured by using an insulation resistance meter,suach as DF2863 insulation resistance meter.

4.4.Measureing Condition:

Parts shall be measured under the standard condition(Temperature: $\pm 23\pm 5^{\circ}\text{C}$, Humidity: $45\pm 10\%\text{R.H.}$)is redulated to measure.

This print and information there in are proprietary to Bestar Electronics Industry Co., Ltd. and shall not be used in whole or in part without its written content.

D	17/07/11	Li u R u f eng	Change Metal Material	Date:	14/01/09	FT-23G-3.5A1-W035	
C	15/03/05	Li u R u f eng	Change Glue	Drawn by:	Ma Guoyang		
B	14/11/20	Li u R u f eng	Add Packaging	Checked by:	M chael	Piezo Ceramic Element	
Rev.	Date	Drawn	Note	Approved by:	Li Hbngyuan		
BESTAR SENSORTECH CO.,LTD						DRG NO: BS/TEY01.453C	Page:03 of 06
www.bestarsensor.com li@bestarsensor.com							

FT-23G-3.5A1-W035

5. Reliability Test:

5.1. High Temperature Test

Temperature +90°C
Duration 240hrs

5.2. Low Temperature Test

Temperature -20°C
Duration 240hrs

5.3. Temperature Cycle Test

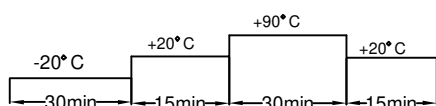

all these tests above should be measured after leaving normal temperature for 2hrs.

Cycles 5

5.4. Humidity

Temperature 40±2°C

Relative Humidity

90~95R.H.

Duration 240hrs

5.5. Vibration Test

Vibration Frequency 10~55Hz

Amplitude 1.52mm

Duration 2 hrs each of 3 axis

5.6. Shock

Piezoelectric disc shall be measured after applying shock at (980m/s²) for each three mutually perpendicular (XYZ) directions by half sine waves, 3 times each

This print and information there in are proprietary to Bestar Electronics Industry Co., Ltd. and shall not be used in whole or in part without its written content.

D	17/07/11	Li u Ruf eng	Change Metal Material	Date:	14/01/09	FT-23G-3.5A1-W035	
C	15/03/05	Li u Ruf eng	Change Glue	Drawn by:	Ma Guoyang		
B	14/11/20	Li u Ruf eng	Add Packaging	Checked by:	Michael	Piezo Ceramic Element	
Rev.	Date	Drawn	Note	Approved by:	Li Hbngyuan		
BESTAR SENSORTECH CO.,LTD www.bestarsensor.com li@bestarsensor.com						DRG NO: BS/TEY01.453C	Page: 04 of 06

FT-23G-3.5A1-W035

6.Packing

6.1 Packing Drawing

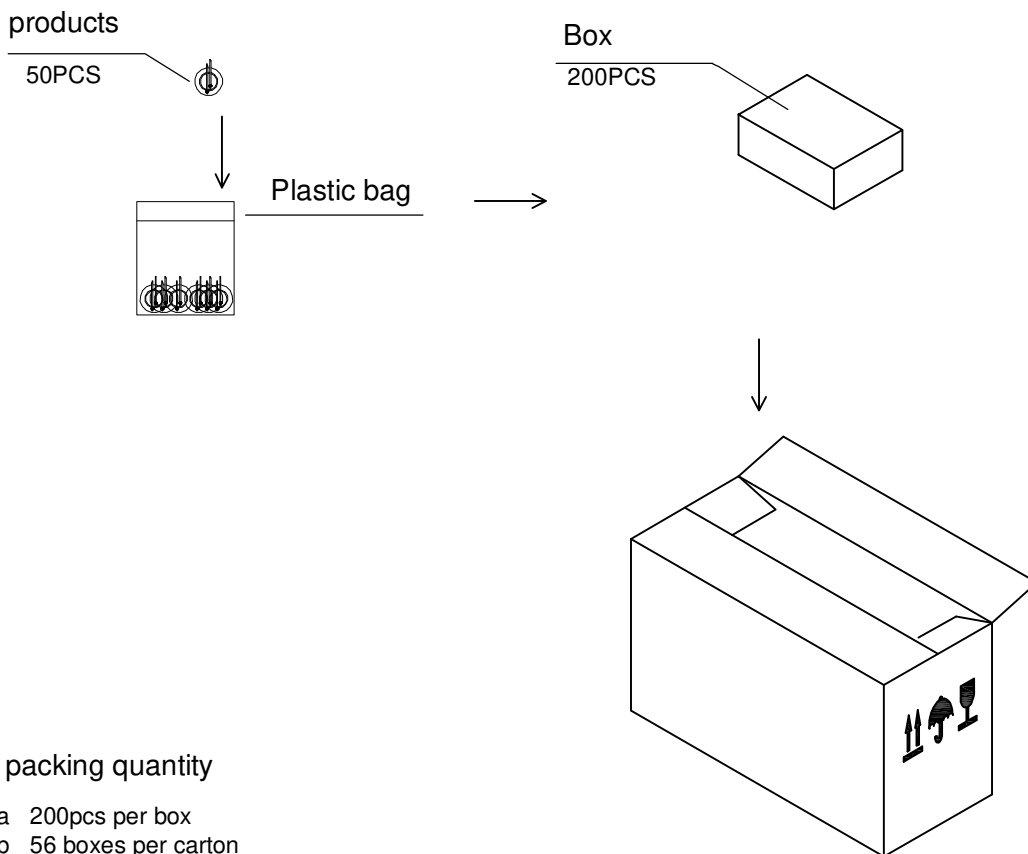

6.2 packing quantity

- 6.2-a 200pcs per box
- 6.2-b 56 boxes per carton
- 6.2-c Total 11200pcs per carton
- 6.2-d Carton size 50x27x26cm
- 6.2-e Piezos shall be packaged in suitable low-sulfur . air tight stacking containers to prevent oxidation of the metal disc. corrosion of the silver electrode. And damage during shipment and storage. Cartons shall be stackable to four feet high without damage to piezos.

This print and information there in are proprietary to Bestar Electronics Industry Co., Ltd. and shall not be used in whole or in part without its written content.

D	17/07/11	Li u Ruf eng	Change Metal Material	Date:	14/01/09	FT-23G-3.5A1-W035	
C	15/03/05	Li u Ruf eng	Change Glue	Drawn by:	Ma Guoyang		
B	14/11/20	Li u Ruf eng	Add Packaging	Checked by:	Michael	Piezo Ceramic Element	
Rev.	Date	Drawn	Note	Approved by:	Li Hongyuan		
BESTAR SENSORTECH CO.,LTD						DRG NO: BS/TEY01.453C	Page:05 of 06
www.bestarsensor.com li@bestarsensor.com							

