

| Rev | AWO # | Description | Date | Appr |
|-----|-------|-------------|---------|------|
| - | | RELEASED | 9/27/21 | |

APPROVED: _____

DATE: _____ TITLE: _____

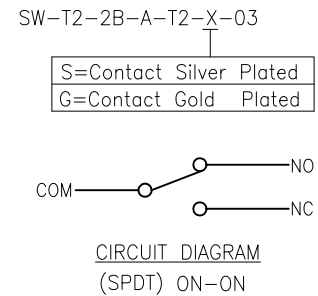
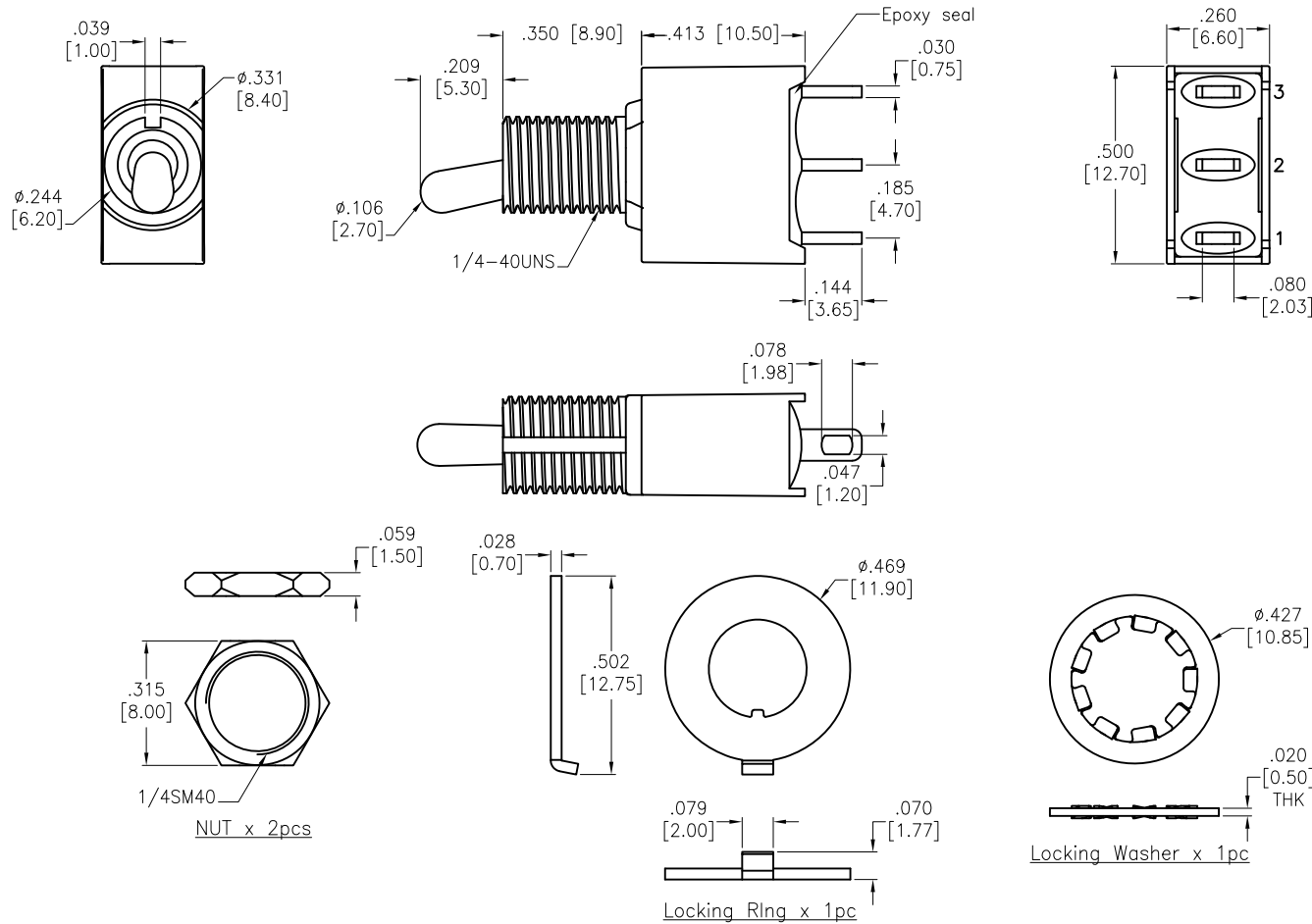

SPECIFICATIONS:

Material:
 Movable contact: Copper Alloy, Silver plated
 Terminals: Silver plated with outer layer in Gold plating
 Electrical:
 Rating: 5 Amps with resistive load @ 125VAC or 28VDC
 2 Amps with resistive load @ 250VAC
 Contact resistance: 10 mohms max initial
 Insulation resistance: 1000 Mohms min
 Dielectric withstanding voltage: 1500V RMS @ sea level
 Electrical life: 50,000 make and break cycles at full load
 Temperature Rating:
 Operating temperature: -30°C to +85°C
 Environmental:
 IP Class: IP67
 Lead free, RoHS compliant



| | | |
|--|-------------|---------|
| UNLESS OTHERWISE SPECIFIED ALL DIMENSIONS ARE INCHES [MM]. TOLERANCES: EXCEPT AS NOTED | | |
| INCHES | | HOLES |
| .X ± .10 | ØX ± .10 | |
| .XX ± .020 | ØXX ± .015 | |
| .XXX ± .015 | ØXXX ± .010 | |
| DRAWN | OW | 9/27/21 |
| CHECKED | AC | 9/27/21 |
| APPROVED | | |
| THIS DRAWING CONTAINS INFORMATION THAT IS PROPRIETARY AND SHOULD NOT BE USED WITHOUT PRIOR WRITTEN PERMISSION FROM ADAM TECH | | |

| | | | |
|---|--------------------------------|---|--|
| ADAM TECH | | 909 Rahway Avenue, Union, NJ 07083 Phone: 908-687-5000 Fax: 908-687-5710 | |
| TITLE MINIATURE TOGGLE SWITCH, SPDT, ON-ON, SOLDER TYPE | | | |
| SIZE X | PART NO. SW-T2-2B-A-T2-X-03 | REV. - | |
| REF: S00198T | SCALE: NTS | SHEET 1 OF 1 | |