

REVISONS		DATE	DWN	APVD
LOC	DIST	DESCRIPTION		
B	REVISED PER	ECO-12-011893	27JUN12	KH PO

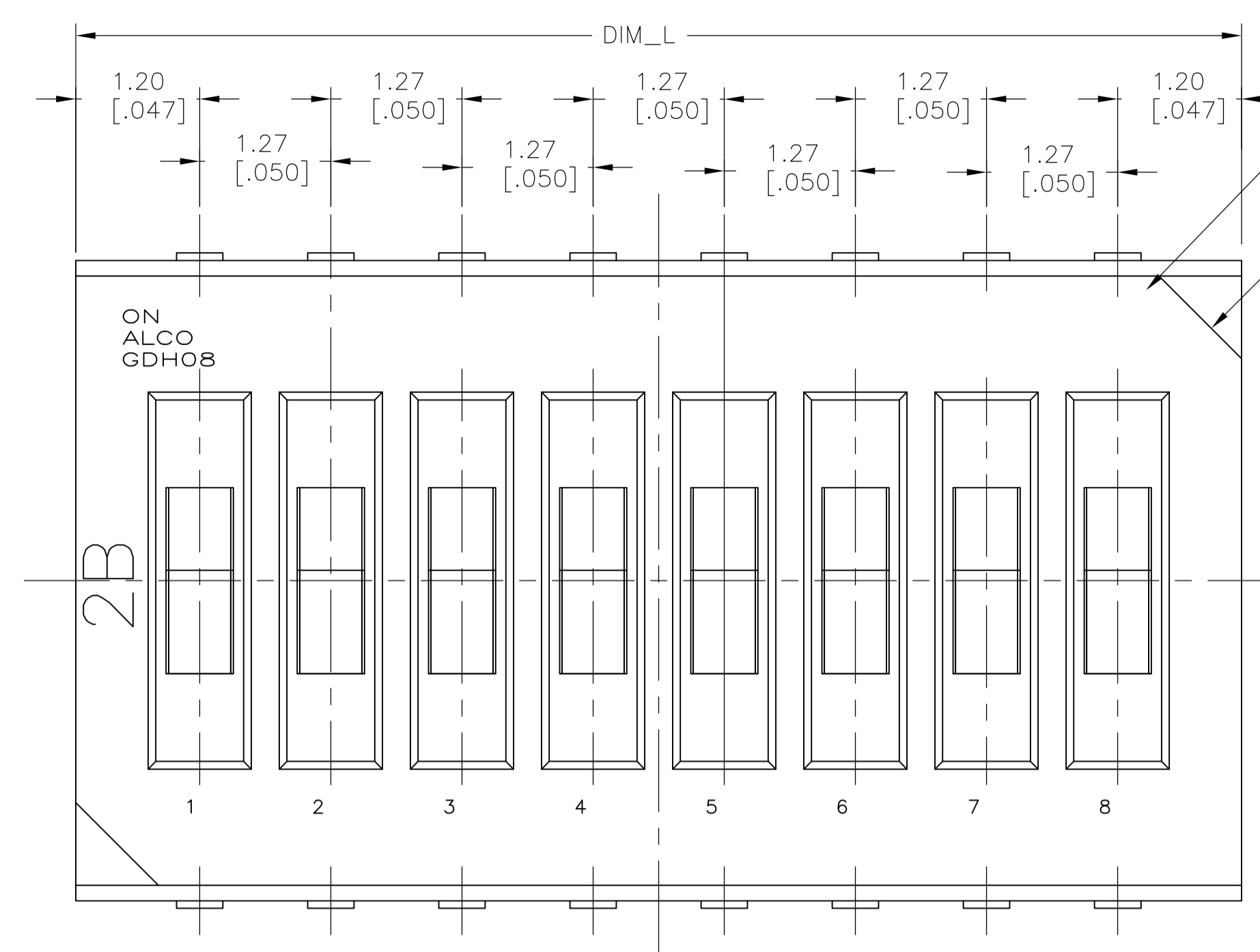

PART NUMBER(2P,4P:NO "ALCO" DISPLAY)
C0.8 [.031]

LOT NO
INDICATION EXAMPLE
2 B
YEAR 2012 MONTH 2

SPECIFICATIONS:

MATERIALS:
CASE-PPS UL94V-0, BLACK
COVER-PPS UL94V-0, BLACK
ACTUATOR-LCP UL94V-0, WHITE
FIXED CONTACT-COPPER ALLOY, GOLD OVER NICKEL PLATE
MOVING CONTACT-COPPER ALLOY, GOLD OVER NICKEL PLATE
TERMINAL-COPPER ALLOY, GOLD OVER NICKEL PLATE
TAPE SEAL-POLYIMIDE FILM

ELECTRICAL:
CONTACT RATING: NON SWITCHING: 100MILLIAMPS @50VDC
SWITCHING: 25MILLIAMPS @24VDC
INITIAL CONTACT RESISTANCE: 100MILLIOHMS MAX @2VDC. 10mA.
CONTACT RESISTANCE(AFTER TESTS): 300MILLIOHMS MAX.@2VDC.10mA
INSULATION RESISTANCE: 100MEG OHMS MIN @100VDC
DIELECTRIC STRENGTH: 300VAC,1MINUTE
LIFE EXPECTANCY: 1000 CYCLES MIN.

MECHANICAL:
ACTUATION FORCE:4.94(490gf) MAX.

ENVIRONMENTAL:
OPERATING TEMPERATURE: -30°C TO +85°C
STORAGE TEMPERATURE: -45°C TO +100°C
SOLDER HEAT RESISTANCE PER 109-201,CONDITION B SWITCH IN OFF POSITION
SOLDERABILITY PER JIS C 0050 & JIS C 0053

- NOTES:**
- SUPPLIED WITH TAPE SEAL STANDARD
 - SWITCH IS TO HAVE OVERALL HEIGHT AS SHOWN
 - ALL MATERIALS AND FINISHES SHALL COMPLY WITH EU DIRECTIVE 2002/ 95 / EC OF 27JAN2003 (ROHS)
 - TAPE AND REEL PACKAGING PER EIA-481

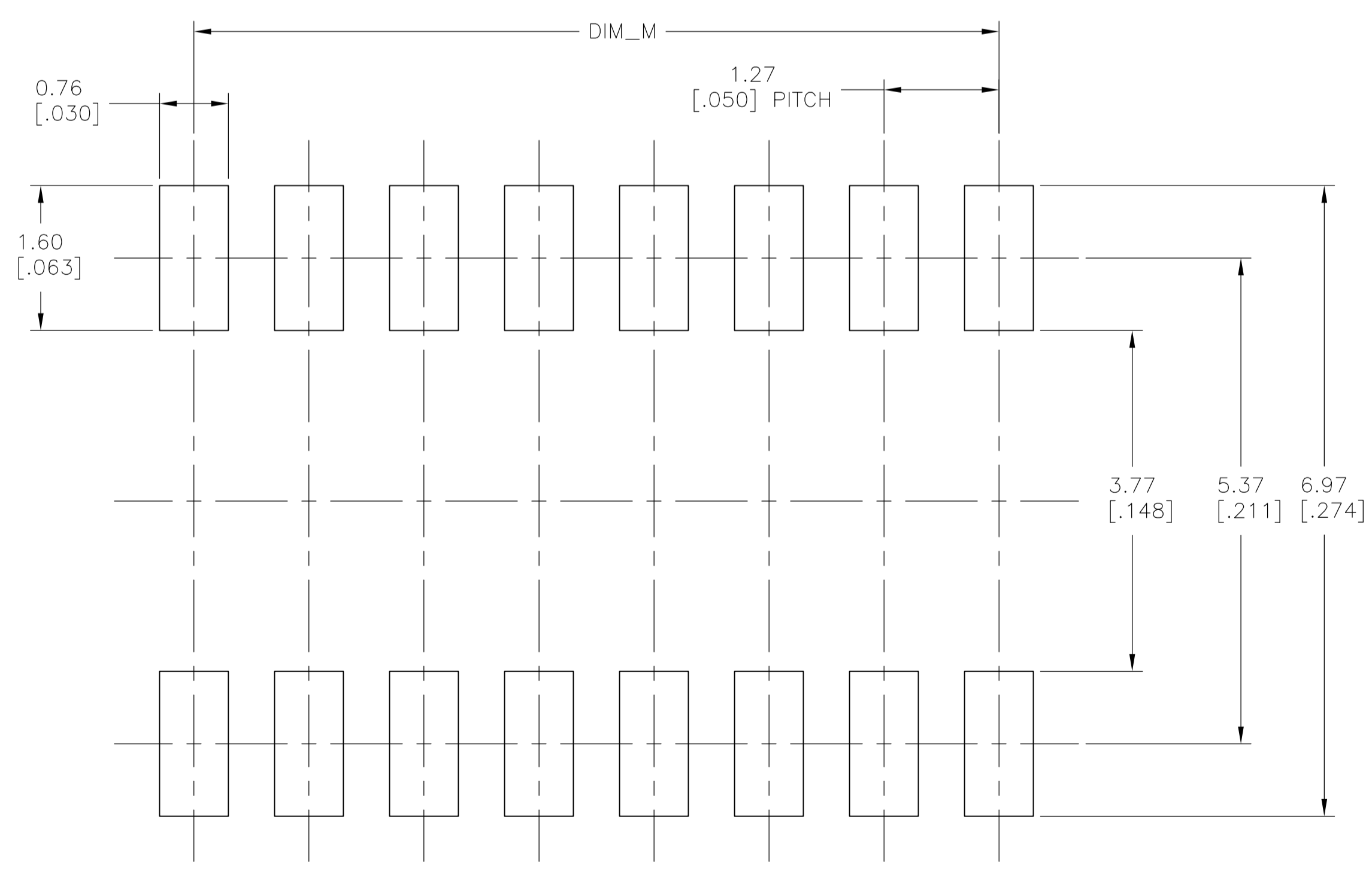
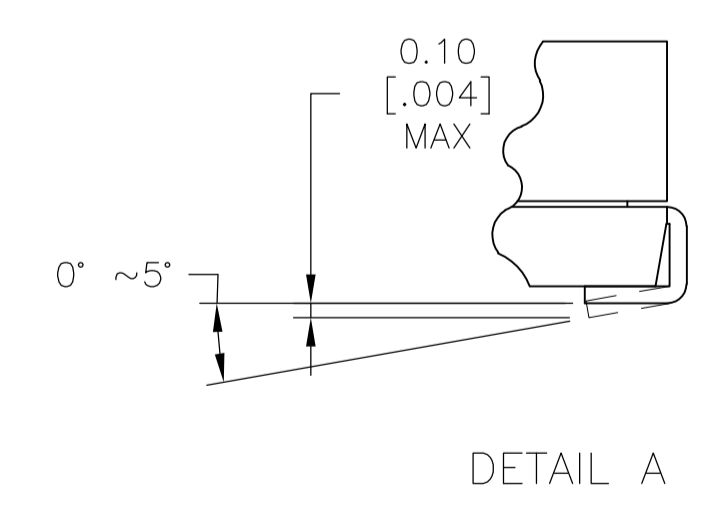
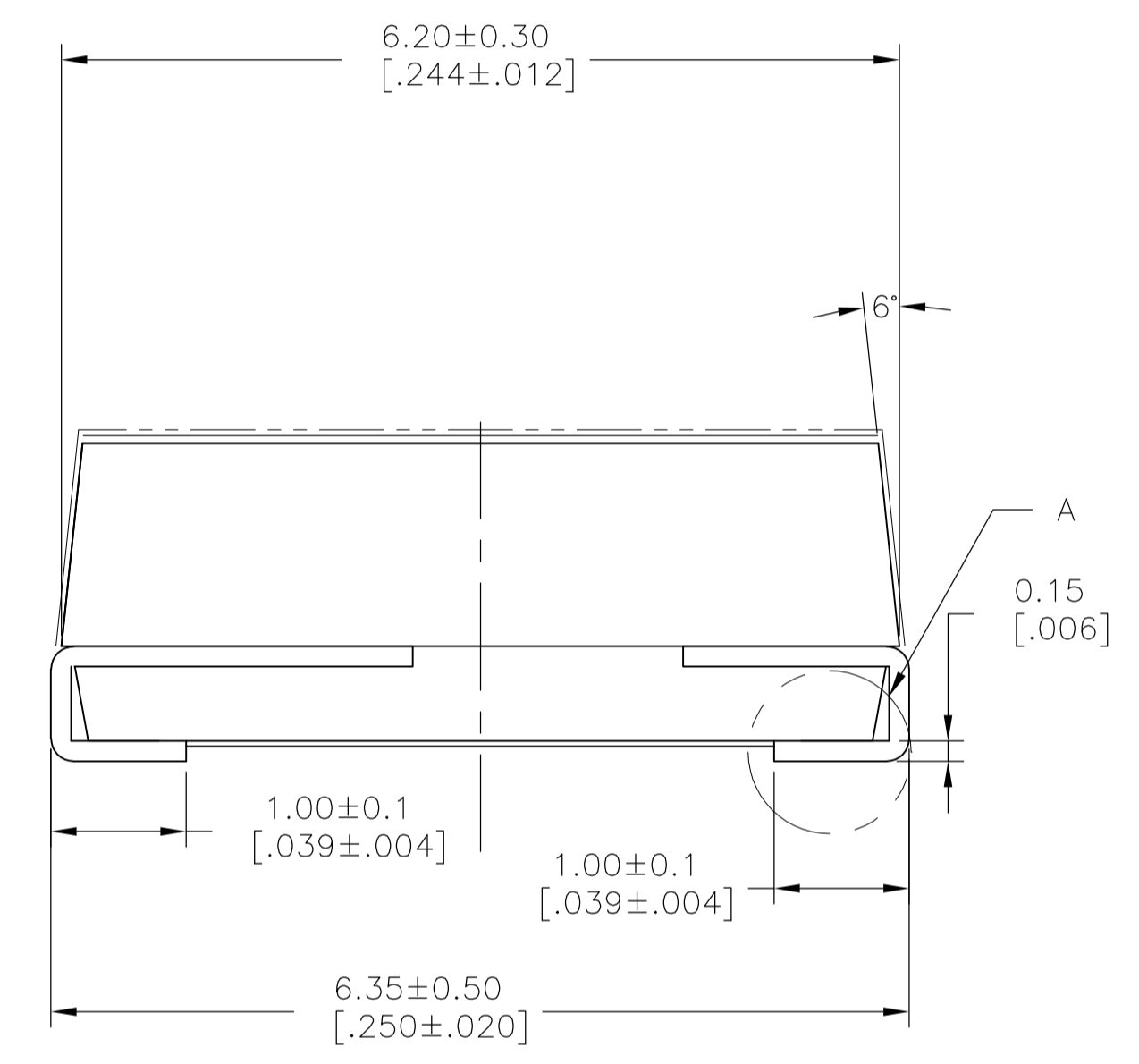
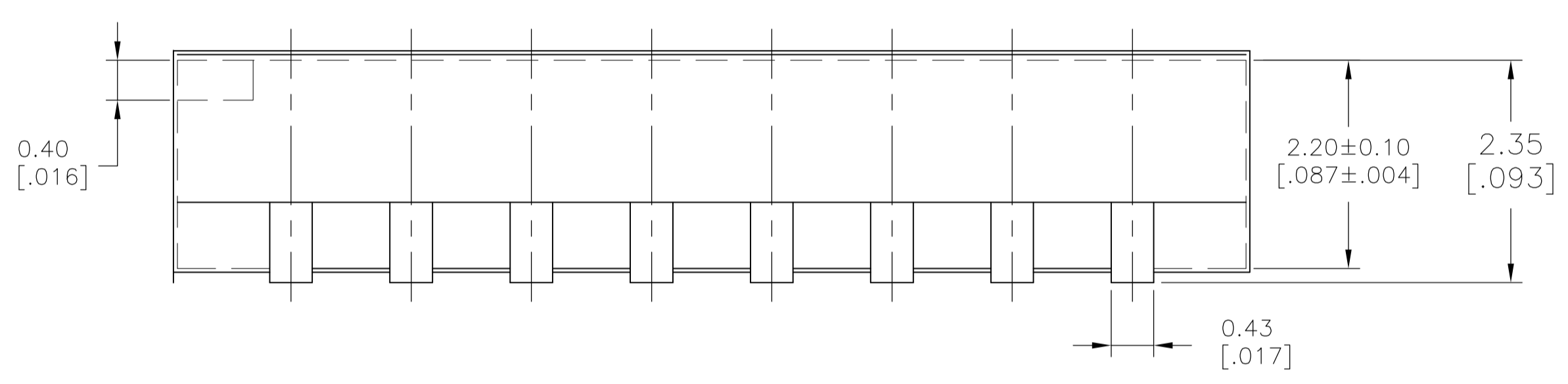

MOUNTING PAD DIMENSIONS(5/1)

POS	DIM M	DIM L	ALCO DISCRPTION	TE P/N
10	11.43[.450]	13.83[.544]	GDH10SATR04	1977831-5
8	8.89[.350]	11.29[.444]	GDH08SATR04	1977831-4
6	6.35[.250]	8.75[.344]	GDH06SATR04	1977831-3
4	3.81[.150]	6.21[.244]	GDH04SATR04	1977831-2
2	1.27[.05]	3.67[.144]	GDH02SATR04	1977831-1

THIS DRAWING IS A CONTROLLED DOCUMENT.

DIMENSIONS: mm [INCHES]

TOLERANCES UNLESS OTHERWISE SPECIFIED:

0. PLC	±	-
1. PLC	±	-
2. PLC	±	0.40[.016]
3. PLC	±	-
4. PLC	±	-
ANGLES	±	-

MATERIAL: - FINISH: -

WEIGHT: -

CUSTOMER DRAWING

DIN: KIRAN HOLAL 30MAR2012
CHK: OTT.PETER 30MAR2012
APVD: OTT.PETER 30MAR2012

NAME: SERIES GDH TAPE AND REEL
GDH02SATR04~GDH10SATR04

SIZE: A1
CAGE CODE: 00779
DRAWING NO: 1977831

RESTRICTED TO: -

SCALE: 20:1 SHEET: 1 OF 1 REV: B