

注記 NOTES

- △1 MX J側を基準に奇数番目の極におけるソルダーテール。
SOLDER TAIL OF ODD CKTS, MXJ MARK AS BASIC.
- △2 MX J側を基準に偶数番目の極におけるソルダーテール。
SOLDER TAIL OF EVEN CKTS, MXJ MARK AS BASIC.
- △3 3極~10極に適用。APPLY FOR 3-10 CKTS.
- △4 3極~19極に適用。APPLY FOR 3-19 CKTS.
- 5. () 内寸法は、参考値。
() DIMENSION IS FOR REFERENCE.
- 6. ソルダーテールは、先端が取付推奨穴にガイドされること。
SOLDER TAILS MAY BE CHECKED BY INSERTION FOR RECOMMENDED PCB BOARD HOLES.
- 7. 本製品は5597-NAPBの鉛フリー品である。
THIS PRODUCT IS LEAD FREE OF 5597-NAPB.

48.25	43.95	39-53-2344	5597-34APB7F	34
45.75	41.45	39-53-2324	5597-32APB7F	32
44.5	40.2	39-53-2314	5597-31APB7F	31
43.25	38.95	39-53-2304	5597-30APB7F	30
42	37.7	39-53-2294	5597-29APB7F	29
40.75	36.45	39-53-2284	5597-28APB7F	28
39.5	35.2	39-53-2274	5597-27APB7F	27
38.25	33.95	39-53-2264	5597-26APB7F	26
37	32.7	39-53-2254	5597-25APB7F	25
35.75	31.45	39-53-2244	5597-24APB7F	24
34.5	30.2	39-53-2234	5597-23APB7F	23
33.25	28.95	39-53-2224	5597-22APB7F	22
32	27.7	39-53-2214	5597-21APB7F	21
30.75	26.45	39-53-2204	5597-20APB7F	20
29.5	25.2	39-53-2194	5597-19APB7F	19
28.25	23.95	39-53-2184	5597-18APB7F	18
27	22.7	39-53-2174	5597-17APB7F	17
25.75	21.45	39-53-2164	5597-16APB7F	16
24.5	20.2	39-53-2154	5597-15APB7F	15
23.25	18.95	39-53-2144	5597-14APB7F	14
22	17.7	39-53-2134	5597-13APB7F	13
20.75	16.45	39-53-2124	5597-12APB7F	12
19.5	15.2	39-53-2114	5597-11APB7F	11
18.25	13.95	39-53-2104	5597-10APB7F	10
17	12.7	39-53-2094	5597-09APB7F	9
15.75	11.45	39-53-2084	5597-08APB7F	8
14.5	10.2	39-53-2074	5597-07APB7F	7
13.25	8.95	39-53-2064	5597-06APB7F	6
12	7.7	39-53-2054	5597-05APB7F	5
10.75	6.45	39-53-2044	5597-04APB7F	4
9.5	5.2	39-53-2034	5597-03APB7F	3
B	A	EDP No.	ENG No.	CIRCUITS
		ORDER No.		

MATERIAL
HOUSING, ACTUATOR : PBT, UL94V-0
TERMINAL : PHOSPHOR-BRONZE, THK : 0.3t

FINISH
TIN-BISMUTH PLATING : 1.0 MICROMETER MINIMUM
OVER NICKEL PLATING : 1.0 MICROMETER MINIMUM

GENERAL TOLERANCE (UNLESS SPECIFIED)		THIS DRAWING CONTAINS INFORMATION THAT IS PROPRIETARY TO MOLEX ELECTRONIC TECHNOLOGIES, LLC AND SHOULD NOT BE USED WITHOUT WRITTEN PERMISSION	
0.25 UNDER	±0.03	DIMENSION UNITS	SCALE
0.25 OVER 0.5 UNDER	±0.05	mm	NTS
0.5 OVER 1.0 UNDER	±0.1	GENERAL TOLERANCES (UNLESS SPECIFIED)	
1.0 OVER 10 UNDER	±0.2	ANGULAR TOL ± 3.0°	
10 OVER 30 UNDER	±0.25	4 PLACES ±	EC NO: 733771 DRWN: ANIKES1 2023/01/13 CHK'D: GGA 2023/02/24 APPR: GGA 2023/02/24
30 OVER	±0.3	3 PLACES ±	
DRAFT WHERE APPLICABLE MUST REMAIN WITHIN DIMENSIONS		2 PLACES ±	
		1 PLACE ±	
		0 PLACES ±	INITIAL REVISION:
		DRWN: MNAGATA 2004/05/26	
		APPR: MSASAO 2004/05/28	
		THIRD ANGLE PROJECTION	DRAWING
		SEE TABLE	A3-SIZE
		SERIES	5597
		MATERIAL NUMBER	SEE TABLE
		CUSTOMER	GENERAL MARKET
		DOCUMENT NUMBER	SD-5597-011
		DOC TYPE	PSD
		DOC PART	001
		REVISION	D1
		SHEET NUMBER	1 OF 2

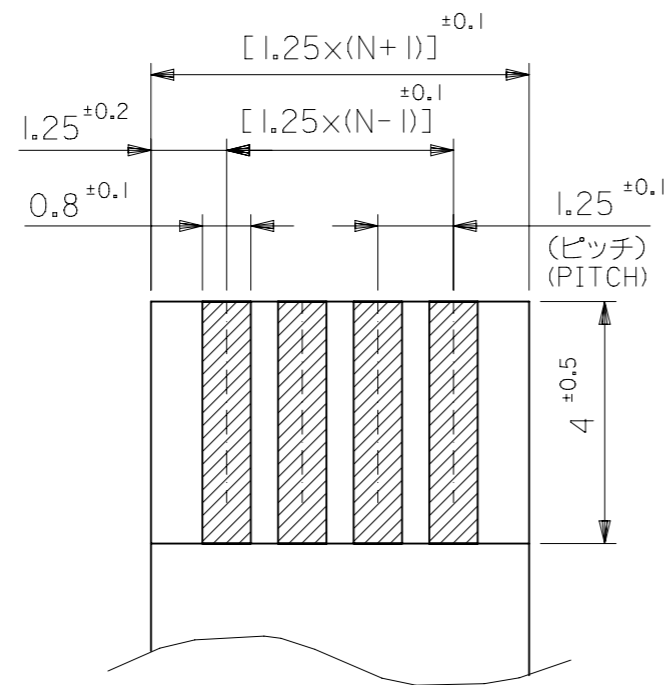

適合FPC/FFC推奨寸法
RECOMMENDED FPC/FFC
厚さ THK : 0.3 ± 0.05

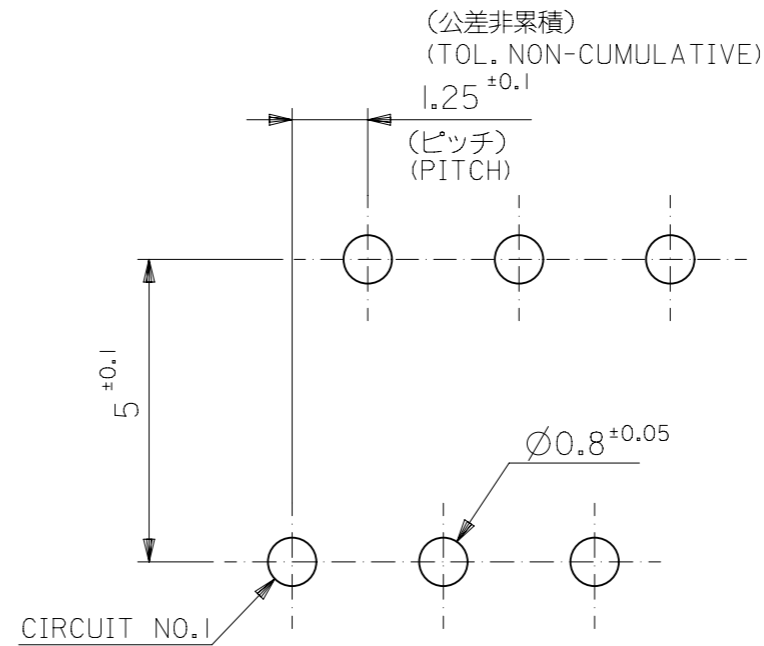

基板取付穴推奨寸法 (t=1.6)
RECOMMENDED P.C. BOARD
HOLE DIMENSION

FPC/FFCについて:

打抜き方向は導体側から補強板側を推奨いたします。
導体部については軟銅箔35マイクロメートルまたは50マイクロメートルを推奨いたします。

ABOUT FPC/FFC

RECOMMENDED PUNCHER DIRECTION : FROM CONDUCTOR SIDE TO STIFFENER FILM SIDE.
RECOMMENDED CONDUCTOR SPEC :
THICKNESS OF SOFT COPPER FOIL : 35 MICROMETER OR 50 MICROMETER.

FPCについて:

補強フィルム材質はポリイミドを推奨します。
接着剤は熱硬化接着剤を推奨します。

ABOUT FPC

RECOMMENDED MATERIAL :
STIFFENER FILM : POLYIMIDE
BONDING AGENT : THERMOSETTING BONDING AGENT

THIS DRAWING CONTAINS INFORMATION THAT IS PROPRIETARY TO MOLEX ELECTRONIC TECHNOLOGIES, LLC AND SHOULD NOT BE USED WITHOUT WRITTEN PERMISSION									
DIMENSION UNITS	SCALE	CURRENT REV DESC: OBSOLETE PART NUMBERS AS PER PCN#510806							
mm	NTS								
GENERAL TOLERANCES (UNLESS SPECIFIED)					1.25 FPC CONNECTOR ASSY ZIF -LEAD FREE-				
ANGULAR TOL ± 3.0°									
4 PLACES	±	EC NO: 733771			PRODUCT CUSTOMER DRAWING				
3 PLACES	±	DRWN: ANIKES1 2023/01/13							
2 PLACES	±	CHK'D: GGA 2023/02/24			SD-5597-011				
1 PLACE	±	APPR: GGA 2023/02/24							
0 PLACES	±	INITIAL REVISION:			PSD 001 D1				
DRAFT WHERE APPLICABLE MUST REMAIN WITHIN DIMENSIONS									
THIRD ANGLE PROJECTION		DRAWING	SERIES	MATERIAL NUMBER	CUSTOMER		DOC TYPE	DOC PART	REVISION
		A3-SIZE	5597	SEE TABLE	GENERAL MARKET		PSD	001	D1
SHEET NUMBER		2 OF 2							