

Tous droits strictement réservés. Reproduction ou communication à des tiers interdite sous quelque forme que ce soit sans autorisation écrite du propriétaire. Propriété de c FCI. Droits de reproduction FCI.

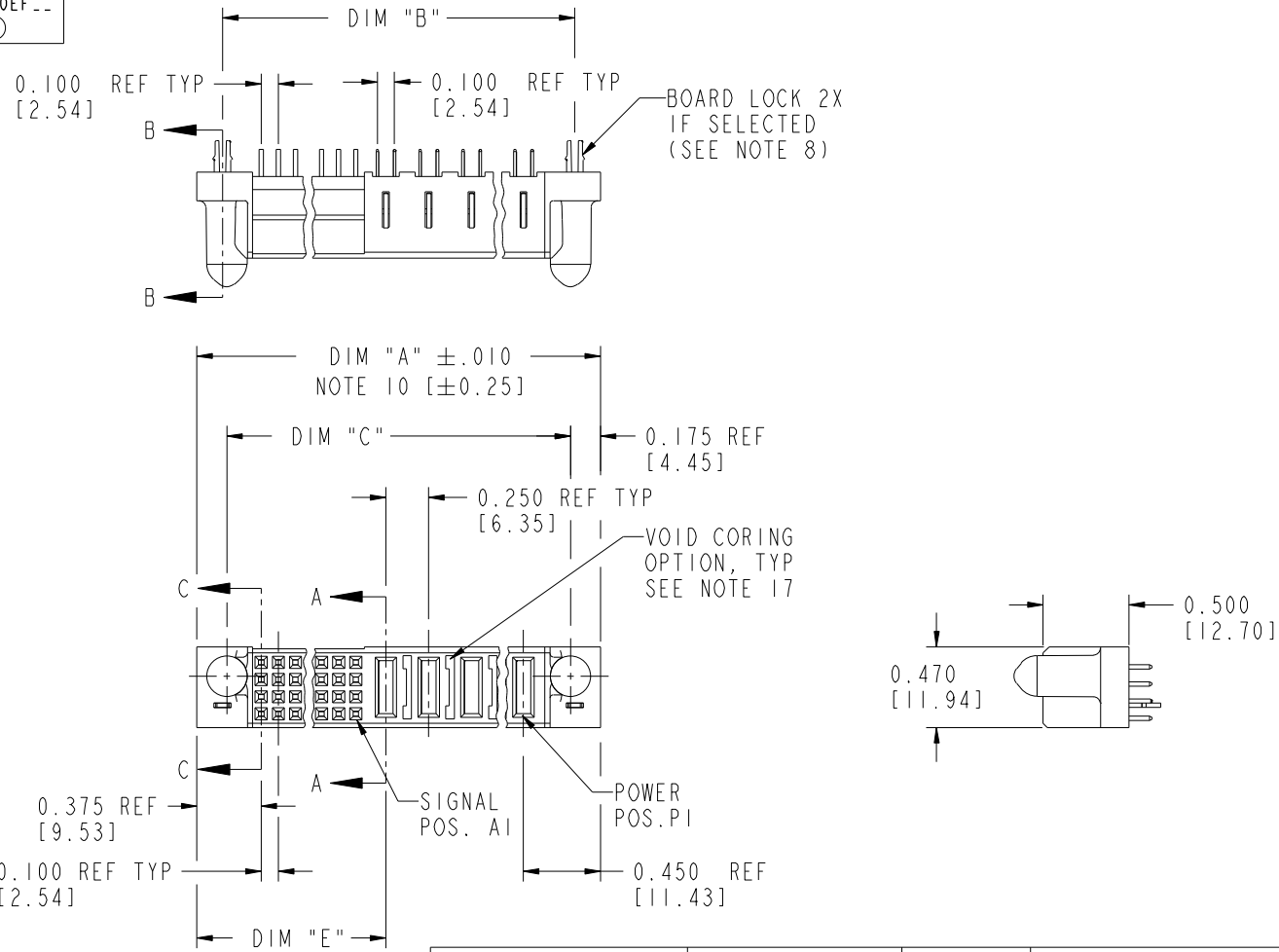

All rights strictly reserved. Reproduction or issue to third parties in any form whatever is not permitted without written authority from the proprietor. Property of FCI. Copyright FCI.

PRODUCT NUMBER
51742-ABBCC00EF--
NOTE: ①



mat'l code				SEE NOTE 2		tolerances unless otherwise specified		CUSTOMER		FCI	
ltr	ecn no.	dr	date	linear	.XX±.01/0.X±0.3	COPY		www.fciconnect.com		title	
H	DG05-0132	SJ	06/02/05		.XXX±.005/0.XX±0.13	projection		VERTICAL RECEPTACLE W/GUIDE PIN		POWER / SIGNAL	
J	DG05-0153	SJ	06/10/05	angles	.XXX±.0020/.XX±.051	INCH/MM		product family		code	
K	DG06-0362	JULIA	08/30/06		0°±2°	scale		PWRBLADE		213	
L	DG08-0239	JC	09/11/08	dr	D. EATON 05-25-99	1:1		size		sheet	
				enr	J. BROWN 05-24-99			dwg no		1 of 3	
				chr	J. BROWN 05-26-99			51742			
				appd	J. BROWN 05-26-99						
sheet index	revision sheet	L	L	L							
		1	2	3							

Pro/E

cage code 22526

Tous droits strictement réservés. Reproduction ou communication à des tiers interdite sous quelque forme que ce soit sans autorisation écrite du propriétaire. Propriété de c FCI. Droits de reproduction FCI.



All rights strictly reserved. Reproduction or issue to third parties in any form whatever is not permitted without written authority from the proprietor. Property of FCI. Copyright FCI.

PRODUCT NUMBER
51742-ABBCC00EF-- NOTE: ①

DIM	LENGTH FORMULAS (SEE NOTE 10)
DIM "A"	.100 [2.54] x (CCC/4) + .250 [6.35] x BB + .650 [16.51] (NOTE 10)
DIM "B"	.100 [2.54] x (CCC/4) + .250 [6.35] x BB + .350 [8.89]
DIM "C"	.100 [2.54] x (CCC/4) + .250 [6.35] x BB + .300 [7.62]
DIM "E"	.100 [2.54] x (CCC/4) + .450 [11.43]
DIM "F"	.100 [2.54] x (CCC/4) + .250 [6.35] x BB + .680 [17.27]
DIM "H"	.100 [2.54] x (CCC/4) + .250 [6.35]

CONNECTOR NOTES

- PRODUCT NUMBER CODE:

51742 - A BB CCC 00 E F LF

 - NO THIS SUFFIX: 100u"/2.54um SnPb ON PCB INTERFACE
 - ADD THIS SUFFIX: 78u"/2.00um Sn ON PCB INTERFACE
 - RETENTION TO PCB (NOTE 8)
 - TAIL OPTIONS (NOTE 7)
 - ALWAYS '00' (ZERO, ZERO) (NOTE 6)
 - NUMBER OF SIGNAL CONTACTS (NOTE 5)
 - NUMBER OF RIGHT POWER CONTACTS (NOTE 4)
 - PLATING (NOTE 3)
 - BASE NUMBER
 - HOUSING MATERIAL: GLASS FILLED V-O HIGH TEMP THERMO PLASTIC.
SIGNAL CONTACT MATERIAL: COPPER ALLOY
POWER CONTACT MATERIAL: COPPER ALLOY
 - PLATING OPTION:
SEE PRINT 10064183 FOR PLATING SPEC OF 51742-1BBCC00EF; 51742-1BBCC00EFLF
 - RIGHT END POWER CONTACT, 01 TO 20 AVAILABLE.
MAXIMUM OF 20 POWER CONTACTS PER CONNECTOR.
 - SIGNAL CONTACTS, 004 TO 148 AVAILABLE.
 - THIS PART NOT AVAILABLE WITH LEFT SIDE POWER CONTACTS.
 - TAIL OPTIONS:
A = .135 ± .010 [3.43 ± .25] SOLDER TO BOARD
C = .135 ± .010 [3.43 ± .25] PRESS FIT
 - RETENTION TO PCB OPTIONS:
A = BOARD LOCK (REQUIRES .098 + .002, -.001 [2.49 +0.05, -0.03] THRU HOLE IN PCB) (NOT AVAILABLE WITH PRESS FIT).
BOARD LOCK TO BE USED IN CONJUNCTION WITH AN .092 PCB OR THICKER.
C = NO RETENTION FEATURE (ALL PRESS FIT).
 - MANUFACTURE'S NAME, P/N, AND DATE CODE TO APPEAR ON THIS SURFACE.
 - THE MAXIMUM OVERALL LENGTH (DIM A) OF A PART IS 8.00 [203.2].
 - PRODUCT SPECIFICATION GS-12-149.
 - REFERENCE 51698 FOR SPECIALS WORKSHEET.
- PCB NOTES:
- ALL DIMENSIONS ARE BASIC UNLESS OTHERWISE SPECIFIED.
 - ALL THROUGH HOLES ARE LOCATED WITH A TRUE POSITION OF .004 [0.01]
 - ALL HOLE DIAMETERS ARE FINISHED HOLE SIZE.
 - 0.0453 ± .001 [1.151 ± .02] DRILLED HOLES PLATED WITH 0.0003 [0.007] MIN SnPb OVER 0.001 [1.03] TO .003 [0.08] PLATING TO ACHIEVE A .040 ± .003 [1.02 ± .08] HOLE.
 - THE VOID CORING IN BETWEEN POWER MODULES, SIGNAL MODULES AND END MODULES ARE OPTIONAL AND THE SHAPE MAY BE DIFFERENT FOR OPTIMIZING THE MOLDING PROCESS. THE VOID CORING WILL NOT EFFECT TO PRODUCT FUNCTION.
 - A ① SYMBOL WILL BE NEXT TO ANY DIMENSION, VIEW, OR NOTE WHICH HAS BEEN MODIFIED WITH THE CURRENT DRAWING REVISION.

mat'l code				SEE NOTE 2		tolerances unless otherwise specified		CUSTOMER		www.fciconnect.com	
ltr	ecn no.	dr	date	linear	.XX±.01/0.X±0.3		COPY		title VERTICAL RECEPTACLE W/GUIDE PIN POWER / SIGNAL		
L					.XXX±.005/0.XX±0.13		projection				
				angles	.XXX±.0020/.XX±.051				product family PWRBLADE code size dwg no 213 sheet 2 of 3		
					0° ± 2°		INCH/MM				
				dr	D. EATON	05-25-99	scale		product family PWRBLADE code size dwg no 51742 sheet 2 of 3		
				enrg	J. BROWN	05-24-99	1:1				
				chr	J. BROWN	05-26-99					
				appd	J. BROWN	05-26-99					
sheet index	revision sheet										



1 | 2 Pro/E 3 | cage code 22526 4

Tous droits strictement reserves. Reproduction ou communication a des tiers interdite sous quelque forme que ce soit sans autorisation écrite du propriétaire. Propriete de c FCI. Droits de reproduction FCI.

All rights strictly reserved. Reproduction or issue to third parties in any form whatever is not permitted without written authority from the proprietor. Property of FCI. Copyright FCI.

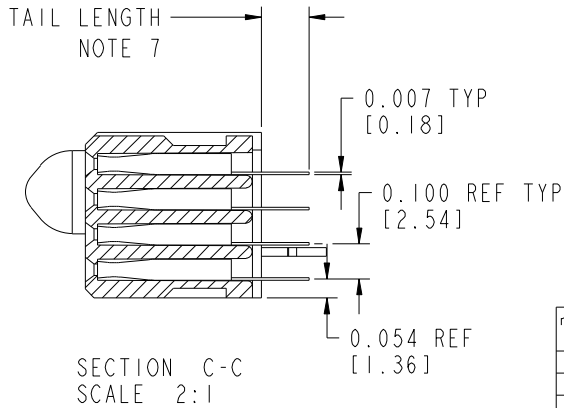
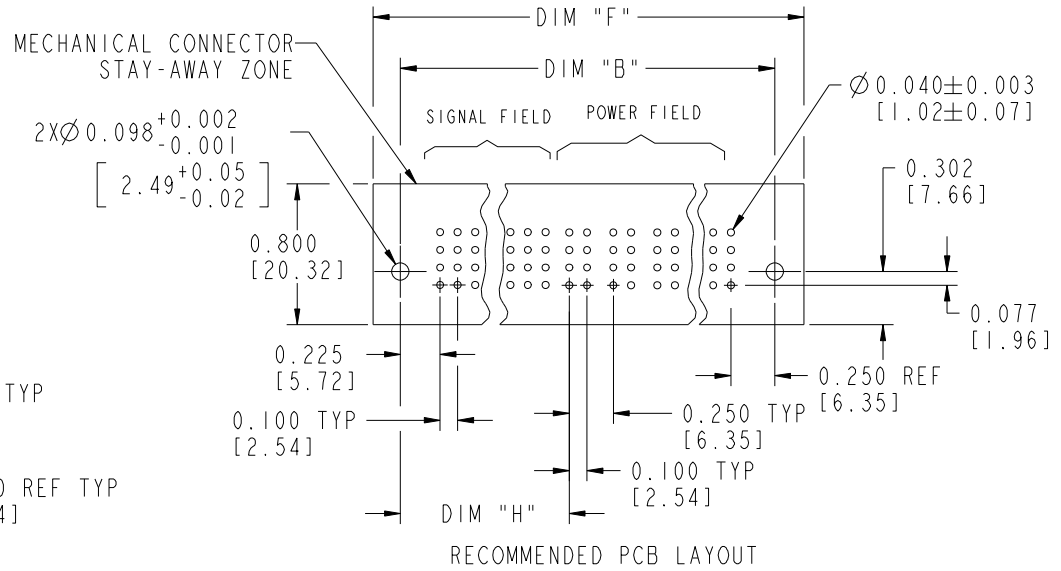
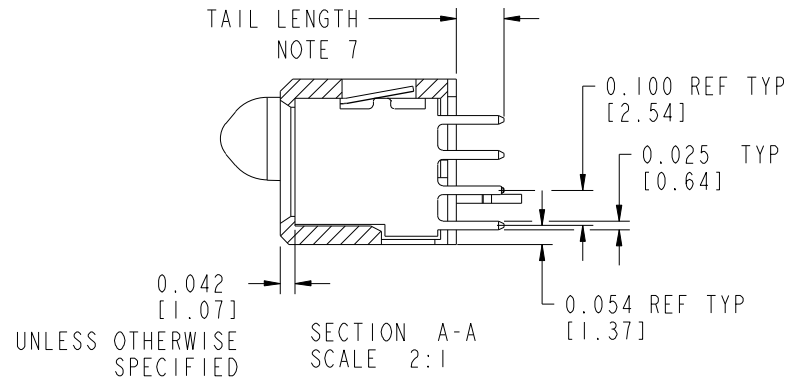
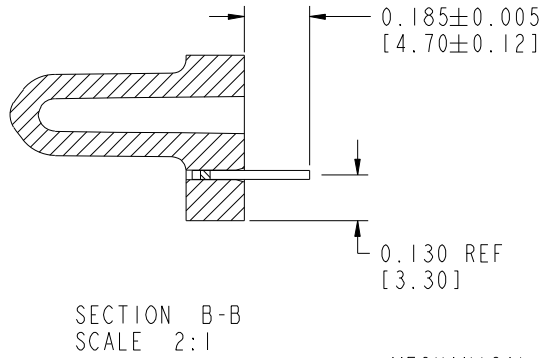
PRODUCT NUMBER
51742-ABBCCC00EF--
NOTE: ①



mat'l code		SEE NOTE 2		tolerances unless otherwise specified		CUSTOMER		 www.fciconnect.com	
ltr	ecn no.	dr	date	linear	.XX±.01/0.X±0.3	COPY		title	
L					.XXX±.005/0.XX±0.13	projection		VERTICAL RECEPTACLE W/GUIDE PIN POWER / SIGNAL	
				angles	.XXX±.0020/.XX±.051			product family	
				dr	0° ± 2°	INCH/MM		PWRBLADE	
				enr	D. EATON 05-25-99	scale		code	
				chr	J. BROWN 05-24-99	1:1		213	
				appd	J. BROWN 05-26-99	A		sheet	
sheet index		revision sheet						3 of 3	

Pro/E

cage code 22526