

NOTES:

1. MATERIALS AND FINISHES:

BODY, LOCK WASHER AND HEX NUT - BRASS, BLACK CHROMATE OVER NICKEL
 INSULATOR AND INSULATOR DISC - PTFE, NATURAL
 CONTACT PIN - BeCu, GOLD PLATING
 FERRULE - COPPER, BLACK CHROMATE OVER NICKEL

2. ELECTRICAL:

A. IMPEDANCE: 50 OHM
 B. FREQUENCY RANGE: DC - 6 GHz
 C. VSWR (RETURN LOSS): 1.20 MAX. (-20.8 dB MIN.)
 D. INSERTION LOSS: < 0.3 dB TO < 0.7 dB @ DC-3 GHz
 E. DIELECTRIC WITHSTANDING VOLTAGE: 1000 VRMS, MIN.

3. MECHANICAL:

A. DURABILITY: 500 CYCLES MIN.
 B. TEMPERATURE RANGE: -65°C TO +165°C
 C. COSMETIC PARAMETERS OF PLATING PER AMPHENOL SPEC. 349-50966.

4. CABLE ASSEMBLY INSTRUCTIONS:

A. TRIM CABLE AS SHOWN.
 B. SLIDE FERRULE AND INSULATOR DISC ONTO CABLE.
 C. SOLDER CABLE CENTER CONDUCTOR TO CONTACT.
 D. INSERT CABLE, UNTIL IT BOTTOMS WITH FOIL ENTERING CONNECTOR AND BRAID OVER KNURL.
 E. CRIMP FERRULE OVER BRAID WITH 0.213" HEX DIE.

5. SHOWS CABLE ENTRY DIMENSIONS.

REVISIONS				
REV	DESCRIPTION	DATE	ECN	BY
A	RELEASE TO MFG.	28-OCT-22	16447	SH

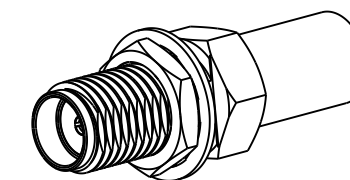

SCALE 2.000

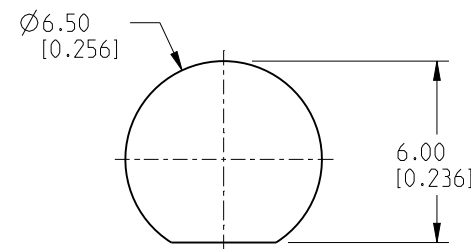

RECOMMENDED MOUNTING HOLE DIMENSIONS

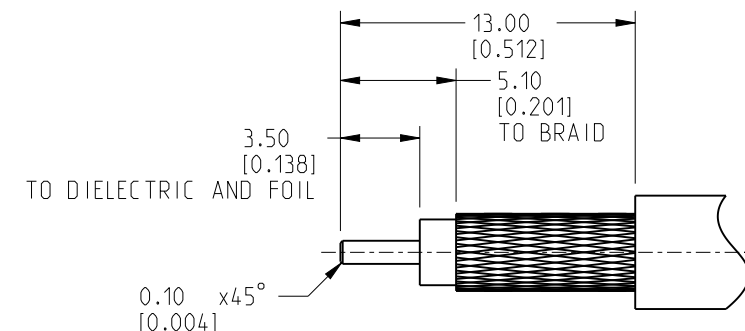

RECOMMENDED CABLE STRIPPING DIMENSIONS

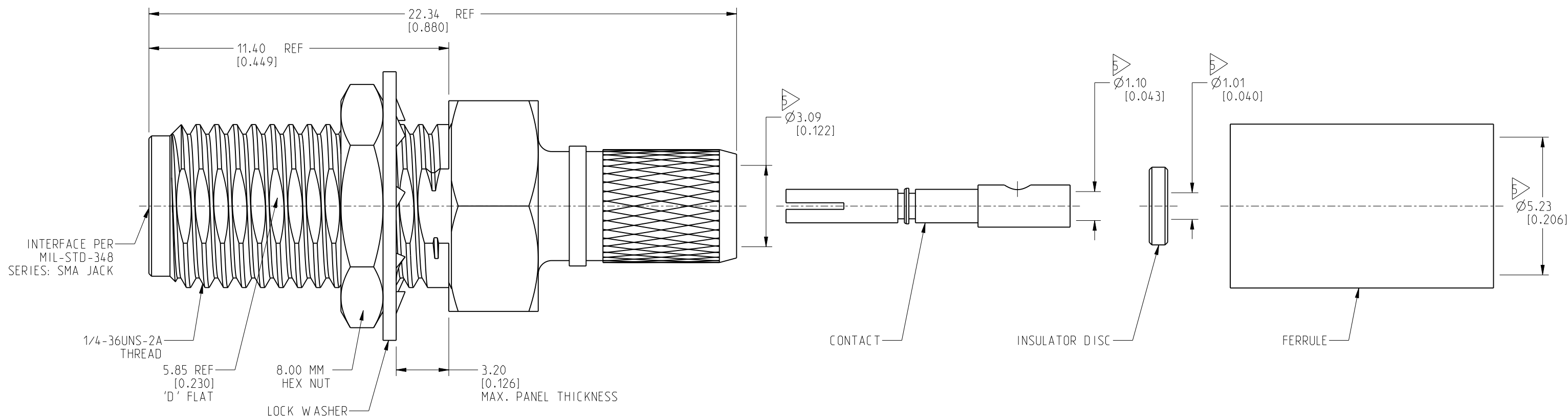

CUSTOMER OUTLINE DRAWING
 ALL OTHER SHEETS ARE FOR INTERNAL USE ONLY

NOTICE: These drawings, specifications, or other data (1) are, and remain the property of Amphenol corp. (2) must be returned upon request; and (3) are confidential and not to be disclosed to any person other than those to whom they are given by Amphenol Corp. The furnishing of these drawings, specifications, or other data by Amphenol Corp., or to any other person to anyone for any purpose is not to be regarded by implication or otherwise in any manner licensing, granting rights to permitting such holder or any other person to manufacture, use or sell any product, process or design, patented or otherwise, that may in any way be related to or disclosed by said drawings, specifications, or other data.		UNLESS OTHERWISE SPECIFIED DIMENSIONS ARE METRIC (INCHES) AND TOLERANCES ARE: <0.5mm = ±0.05mm [-0.020 = ±0.002] 0.5 - 6mm = ±0.1mm [-0.020 - 0.236 = ±0.004] >6.00 - 30mm = ±0.2mm [-0.236 - 1.181 = ±0.008] >30.00 - 120mm = ±0.3mm [-1.181 - 4.725 = ±0.012]		MATERIAL SEE NOTES		TITLE SMA STR BHD JACK FOR LMR/FBT 195 CABLE BLACK PLATED		Amphenol RF	
THIRD ANGLE PROJ.		REFERENCE		ENGR.1 THAMBI RAJ ENGR.2 JACK LIANG DATE 24-AUG-22		SHEET NO. 2 OF 2 SCALE: 6.8:1.0		DRAWING NO. SMA6411A1-BZNT5GP-LMR195-50 ITEM NO. 116411AGP157U5F PART NO. 132454-BC	
EAR# 11380		ANGLES = ±1°		DATE 24-AUG-22		B		REV A	