

National Semiconductor is now part of
Texas Instruments.

Search <http://www.ti.com/> for the latest technical
information and details on our current products and services.

LM3658

Dual Source USB/AC Li Chemistry Charger IC for Portable Applications

General Description

The LM3658 is a single chip charger IC designed for handheld applications. It can safely charge and maintain a single cell Li-Ion/Polymer battery operating from an AC wall adapter or USB power source. Input power source selection of USB/AC is automatic. With both power sources present, the AC power source has priority. Charge current is programmed through an external resistor when operating from an AC wall adapter allowing charge currents from 50 mA to 1000 mA. When the battery is charged using USB power, charge currents of 100 mA or 500 mA are pin-selectable. The termination voltage is controlled to within $\pm 0.35\%$ of 4.2V.

The LM3658 requires few external components and integrates internal power FETs, reverse current protection and current sensing. The internal power FETs are thermally regulated to obtain the most efficient charging rate for a given ambient temperature.

The LM3658 operates in five modes: pre-qualification mode, constant-current mode, constant-voltage mode, top-off mode and maintenance mode. Additionally, the charger IC operates as a linear regulator in "LDO mode", when the AC wall adapter is connected and no battery is present. Optimal battery management is obtained through thermal regulation, battery temperature measurement and multiple safety timers. The LM3658 provides two open-drain outputs for LED status indication or connection to GPIOs.

Features

- Integrated power FETs with thermal regulation
- Charges from either an AC wall adapter or USB power source with automatic source selection
- 50 mA to 1000 mA charge currents using AC wall adapter
- Pin-selectable USB charge currents of 100 mA or 500 mA
- LDO mode with 1A of source current is automatically invoked when the battery is absent and the AC wall adapter is connected
- Continuous battery temperature monitoring
- Built-in multiple safety timers
- Charge status indication
- Continuous over-current and temperature protection
- Near-depleted battery pre-conditioning
- Sleep mode with ultra low quiescent current
- On-board Kelvin-sensing achieves $\pm 0.35\%$ termination accuracy
- Maintenance mode with automatic recharge
- Thermally enhanced 3 mm x 3 mm LLP package

Applications

- Smartphones
- Digital still cameras
- PDAs
- Hard Drive and flash-based MP3 players
- USB-powered devices

Typical Application

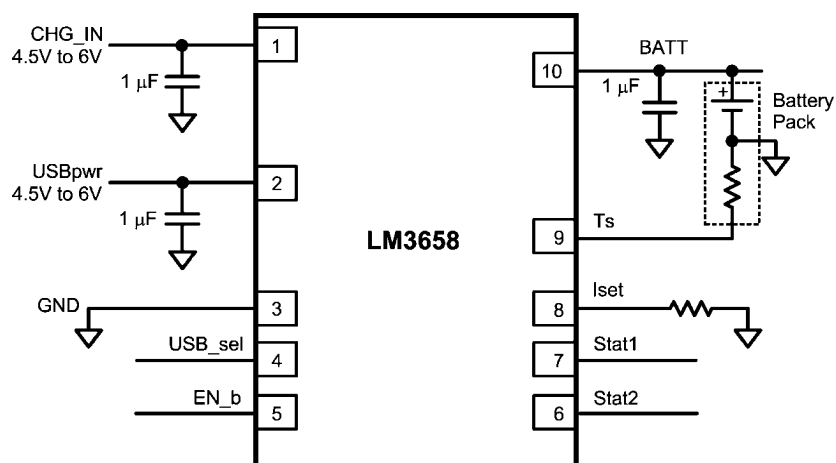

20128201

Connection Diagram and Package Mark Information

LLP10 Package Drawing

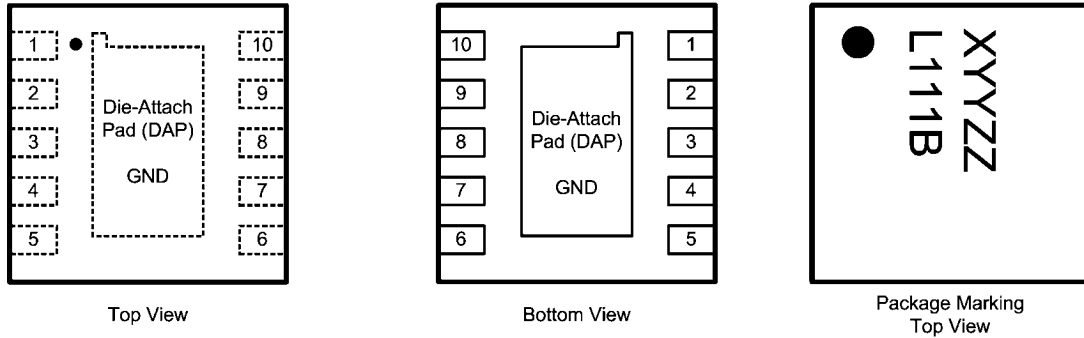

20128202

Note: The actual physical placement of the package marking will vary from part to part. The package marking "X" is the manufacturing plant code. "YY" is a 2-digit date code, and "ZZ" for die traceability. These codes will vary considerably. "L111B" identifies the device (part number, option, etc.).

Pin Descriptions

| Pin # | Name | Description |
|-------|------------------|--|
| 1 | CHG_IN | AC wall adapter input pin. |
| 2 | USBpwr | USB power input pin. |
| 3 | GND | Power and signal ground pin. |
| 4 | USB_sel | Pulling this pin low limits the USB charge current to 100 mA. Pulling this pin high limits the USB charge current to 500 mA. |
| 5 | EN_b | Pulling this pin low enables the charger. Pulling this pin high disables the charger. |
| 6 | STAT2 | Active low open-drain output. Indicates charger status. This pin is capable of driving an LED as well as GPIOs. See Operation Description section for more detail. |
| 7 | STAT1 | Active low open-drain output. Indicates charger status. This pin is capable of driving an LED as well as GPIO. See Operation Description section for more detail. |
| 8 | I _{SET} | A resistor is connected between this pin and GND. The resistor value determines the full-rate charge current when using the AC source. |
| 9 | T _S | Battery temperature sense pin. This pin must be connected to battery pack's temperature sense output pin. For the LM3658SD-B version, leaving this pin open indicates that the battery pack is not present. The charger IC will invoke LDO mode if this pin is left floating. See Operation Description section for more detail. |
| 10 | BATT | Positive battery terminal connection. |

Ordering Information

| Order Number | 5 Hour Timer | Selectable Timer | LDO Mode | No LDO Mode | Package Marking | Supplied As |
|--------------|--------------|------------------|----------|-------------|-----------------|---------------------------|
| LM3658SD | X | | | X | L111B | 1000 units, Tape-and-Reel |
| LM3658SDX | X | | | X | L111B | 4500 units, Tape-and-Reel |
| LM3658SD-A | | X | | X | L155B | 1000 units, Tape-and-Reel |
| LM3658SDX-A | | X | | X | L155B | 4500 units, Tape-and-Reel |
| LM3658SD-B | X | | X | | L156B | 1000 units, Tape-and-Reel |
| LM3658SDX-B | X | | X | | L156B | 4500 units, Tape-and-Reel |

For more information on the various options, please refer to Operation Description section.

Absolute Maximum Ratings (Notes 1, 2)

If Military/Aerospace specified devices are required, please contact the National Semiconductor Sales Office/ Distributors for availability and specifications.

| | |
|--------------------------------------|---------------------------|
| CHG_IN, USBpwr (V_{CC}) | -0.3V to +6.5V |
| All other pins except GND | -0.3V to CHG_IN or USBpwr |
| Power Dissipation (Note 3) | Internally Limited |
| Junction Temperature (T_{J-MAX}) | +150°C |

| | |
|---------------------------|-----------------|
| Storage Temperature Range | -65°C to +150°C |
| ESD Rating (Note 4) | |
| Human Body Model: | 2.0 kV |
| Machine Model: | 200V |

Operating Ratings (Notes 1, 2)

| | |
|--------------------------------------|--------------------|
| Input Voltage Range for CHG_IN | 4.5V to 6.0V |
| Input Voltage Range for USB_pwr | 4.35V to 6.0V |
| Recommended Load Current | 0 to 1000 mA |
| Power Dissipation (Note 3) | Internally Limited |
| Junction Temperature (T_J) Range | -40°C to +125°C |
| Ambient Temperature (T_A) Range | -40°C to +85°C |

Thermal Properties

| | |
|---|--------|
| θ_{JA} , Junction-to-Ambient Thermal Resistance (Note 5) | 54°C/W |
|---|--------|

Electrical Characteristics

Unless otherwise noted, V_{CC} (V_{CHG_IN} and/or V_{USBpwr}) = 5V, $V_{BATT} = 3.5V$.

$C_{CHG_IN} = 1 \mu F$, $C_{USBpwr} = 1 \mu F$, $C_{BATT} = 1 \mu F$. Typical values and limits appearing in normal type apply for $T_J = 25^\circ C$. Limits appearing in **boldface** type apply over $T_J = 0^\circ C$ to $+85^\circ C$. (Notes 2, 6, 7)

| Symbol | Parameter | Conditions | Min | Typ | Max | Units |
|-------------------|---|--|----------------------|-----------|----------------------|---------|
| CHARGER | | | | | | |
| V_{CHG_IN} | AC Wall Adapter Input Voltage Range | | 4.5 | | 6.0 | V |
| V_{USBpwr} | USB Input Voltage Range | | 4.35 | | 6.0 | V |
| I_{CC_PD} | Quiescent Current in Power Down Mode | $V_{BATT} > V_{CC} - V_{OK_CHG}$ | | 1 | 5 | μA |
| I_{CC_STBY} | Quiescent Current in Standby Mode | $V_{BATT} < V_{CC} - V_{OK_CHG}$ $V_{CC} > V_{POR}$ $EN_b = High$ | | 400 | 600 | μA |
| I_{BATT_PD} | Battery Leakage Current in Power Down Mode | $V_{BATT} > V_{CC} + V_{OK_CHG}$ | | 0.01 | 2.0 | μA |
| I_{BATT_MAINT} | Battery Leakage Current in Maintenance Mode | STAT1 = off, STAT2 = on, adapter or USB connected, $V_{BATT} = 4.2V$ | | 7 | 15 | μA |
| V_{OK_CHG} | CHG_IN or USBpwr OK Trip-Point | $V_{CC} - V_{BATT}$ (Rising) $V_{CC} - V_{BATT}$ (Falling) | | 200 50 | | mV |
| V_{POR} | V_{CC} POR Trip-Point | V_{CC} (Rising) $V_{BATT} < V_{CC} - V_{OK_CHG}$ $V_{FULL_RATE} < V_{BATT} < V_{TERM}$ | | 3.0 | | V |
| V_{TERM} | Battery Charge Termination Voltage | $I_{CHG} = 10\%$ of its value when $V_{BATT} = 3.5V$ | | 4.2 | | V |
| | Battery Charge Termination Voltage Tolerance | $T_A = 25^\circ C$ $T_A = 0^\circ C$ to $85^\circ C$ | -0.35 -1.5 | | +0.35 +1.5 | % |
| V_{CHG_DO} | CHG_IN Drop-Out Voltage | $V_{BATT} = V_{TERM}$, $I_{CHG} = 1A$ $V_{CC} > V_{BATT} + V_{CHG_DO_MAX}$ | | 500 | | mV |
| V_{USB_DO} | USBpwr Drop-Out Voltage | $V_{BATT} = V_{TERM}$, USB_sel = high $V_{CC} > V_{BATT} + V_{USB_DO_MAX}$ | | 250 | | mV |
| I_{CHG} | CHG_IN Full-Rate Charge Current Range (see full-rate charge mode description) | $6V \geq V_{CC} \geq 4.5V$ $V_{BATT} < V_{CC} - V_{OK_CHG}$ $V_{FULL_RATE} < V_{BATT} < V_{TERM}$ $I_{CHG} = K_{ISET}/R_{ISET}$ | 50 | | 1000 | mA |

| Symbol | Parameter | Conditions | Min | Typ | Max | Units |
|------------------------|---|--|-------------|------|-------------|-------|
| I _{CHG} | CHG_IN Full Rate Charge Current | R _{ISET} = 10kΩ | 220 | 245 | 270 | mA |
| | | R _{ISET} = 5 kΩ | 465 | 500 | 535 | |
| | | R _{ISET} = 3.3kΩ | 700 | 760 | 820 | |
| K _{ISET} | Charge Current Set Coefficient I _{CHG} = K _{ISET} /R _{ISET} (see full-rate charge mode description) | 6V ≥ V _{CC} ≥ 4.5V V _{BATT} < V _{CC} - V _{OK_CHG} V _{FULL_RATE} < V _{BATT} < V _{TERM} | | 2500 | | AΩ |
| V _{ISET} | Charge Current Set Voltage | 6V ≥ V _{CC} ≥ 4.5V V _{BATT} < V _{CC} - V _{OK_CHG} V _{FULL_RATE} < V _{BATT} < V _{TERM} | | 2.5 | | V |
| I _{USB_L} | USB Full-Rate Charge Low Current | | 80 | 90 | 100 | mA |
| I _{USB_H} | USB Full-Rate Charge High Current | | 400 | 450 | 500 | mA |
| I _{PREQUAL} | Pre-Qualification Current | V _{BATT} = 2V, for both AC adapter and USB | 35 | 45 | 55 | mA |
| V _{FULL_RATE} | Full-Rate Qualification Threshold | V _{BATT} rising, transition from pre-qualification to full-rate charging | 2.9 | 3.0 | 3.1 | V |
| | Full Rate Hysteresis | V _{BATT} falling | 50 | 60 | 70 | mV |
| I _{EOC} | End-of-Charge Current, Percent from Full-Range Current | 6V ≥ V _{CC} ≥ 4.5V V _{BATT} < V _{CC} - V _{OK_CHG} V _{FULL_RATE} < V _{BATT} < V _{TERM} | 7 | 9 | 11 | % |
| I _{TOPOFF} | Minimum Top-Off Charge Current | 6V ≥ V _{CC} ≥ 4.5V V _{BATT} < V _{CC} - V _{OK_CHG} V _{BATT} = V _{TERM} | 1.25 | 2.5 | 3.75 | % |
| V _{RESTART} | Restart Threshold Voltage | V _{BATT} falling, transition from EOC to pre-qualification mode | 3.94 | 4.0 | 4.07 | V |
| V _{TL} | Battery Temperature Sense Comparator Low-Voltage Threshold | | 0.46 | 0.49 | 0.52 | V |
| V _{TH} | Battery Temperature Sense Comparator High-Voltage Threshold | | 2.44 | 2.49 | 2.54 | V |
| I _{TSENSE} | Battery Temperature Sense Current | | 94 | 100 | 106 | μA |
| T _{REG} | Regulated Junction Temperature | | | 120 | | °C |
| T _{SD} | Thermal Shutdown Temperature | | | 165 | | °C |
| V _{TLDO} | LDO mode detection threshold | TS pin voltage for entry into LDO mode. For LM3658SD-B only | 3.95 | 4.0 | | v |
| V _{LDO} | LDO Mode Regulation | 6V ≥ V _{CHG_IN} ≥ 4.5V T _S = Floating I _{BATT} = 100mA | -3.0 | 4.2 | +3.0 | % |

| Symbol | Parameter | Conditions | Min | Typ | Max | Units |
|-----------------------------|--|---|-----|------|-----|-------|
| DETECTION AND TIMING | | | | | | |
| T _{POK} | Power OK Deglitch Time | V _{BATT} < V _{CC} – V _{OK_CHG} | 40 | 60 | 100 | ms |
| T _{PREQUAL} | Pre-Qualification Timer | | 27 | 30 | 33 | mins |
| T _{PQ_FULL} | Deglitch Time for Pre-Qualification to Full-Rate Charge Transition | | 270 | 300 | 330 | ms |
| T _{FULL_PQ} | Deglitch Time for Full-Rate to Pre-Qualification Transition | | 270 | 300 | 330 | ms |
| T _{CHG} | Charge Timer | LM3658SD, LM3658SD-B and LM3658SD-A with USB_sel=high | 270 | 300 | 330 | mins |
| | | LM3658SD-A with USB_sel=low | 540 | 600 | 660 | |
| T _{EOC} | Deglitch Time for End-of-Charge Transition | | 270 | 300 | 330 | ms |
| T _{BATTEMP} | Deglitch Time for Battery Temperature Fault | | 20 | 40 | 80 | ms |
| T _{DGL} | Deglitch Time for EN_b and USB_sel Pins | | 20 | 40 | 80 | ms |
| T _{ITOPPOFF} | Deglitch Time for I _{TOPOFF} | | 270 | 300 | 330 | ms |
| T _{TOPOFF} | Top-Off Charging Timer | LM3658SD, LM3658SD-B and LM3658SD-A with USB_sel=high | 27 | 30 | 33 | mins |
| | | LM3658SD-A with USB_sel=low | 54 | 60 | 66 | |
| I/O | | | | | | |
| V _{IL} | Low-Level Input Voltage | EN_b | 0 | | 0.7 | V |
| | | USB_sel | | | 1.5 | |
| V _{IH} | High-Level Input Voltage | EN_b | 1.4 | | | V |
| | | USB_sel | 2.5 | | | |
| I _{OL} | Low-Level Output Current | STAT1, STAT2, output voltage = 0.25V | 10 | 25 | | mA |
| I _{OH} | High-Level Output Current | STAT1, STAT2, output voltage = 6.0V | | 0.01 | 1 | μA |

Note 1: Absolute Maximum Ratings indicate limits beyond which damage to the component may occur. Operating Ratings are conditions under which operation of the device is guaranteed. Operating Ratings do not imply guaranteed performance limits. For guaranteed performance limits and associated test conditions, see the Electrical Characteristics tables.

Note 2: All voltages are with respect to the potential at the GND pin.

Note 3: The LM3658 has built-in thermal regulation to regulate the die temperature to 120°C. See Operation Description section for more detail.

Note 4: The Human body model is a 100 pF capacitor discharged through a 1.5 kΩ resistor into each pin. The machine model is a 200 pF capacitor discharged directly into each pin. MIL-STD-883 3015.7

Note 5: Junction-to-ambient thermal resistance is highly application and board-layout dependent. In applications where high maximum power dissipation exists, special care must be paid to thermal dissipation issues in board design. Please refer to application note AN1187 for more detail.

Note 6: Min and Max limits are guaranteed by design, test, or statistical analysis. Typical numbers are not guaranteed, but do represent the most likely norm.

Note 7: LM3658 is not intended as a Li-Ion battery protection device; battery used in this application should have an adequate internal protection.

Block Diagram

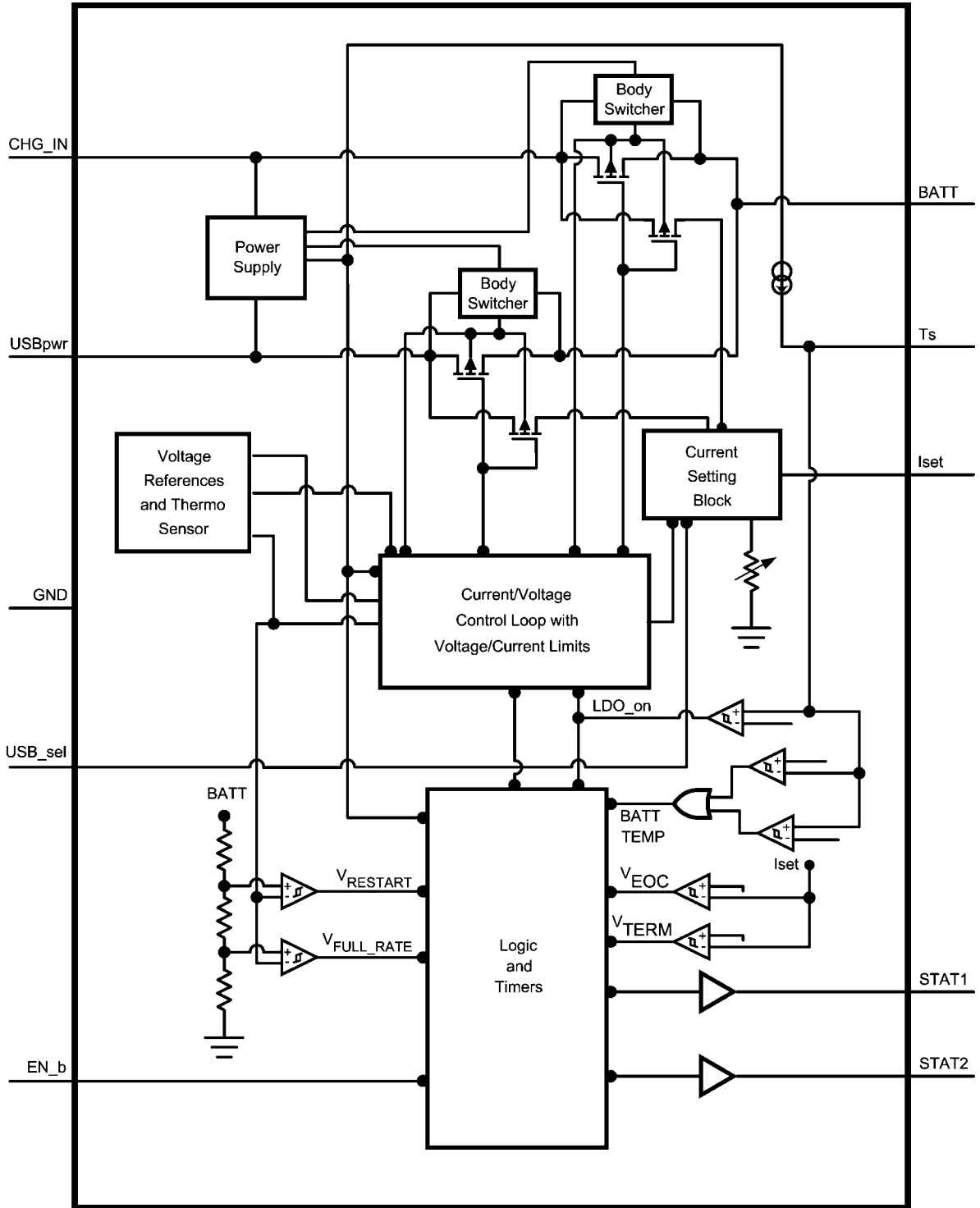

20128203

Li-Ion Charging Profile

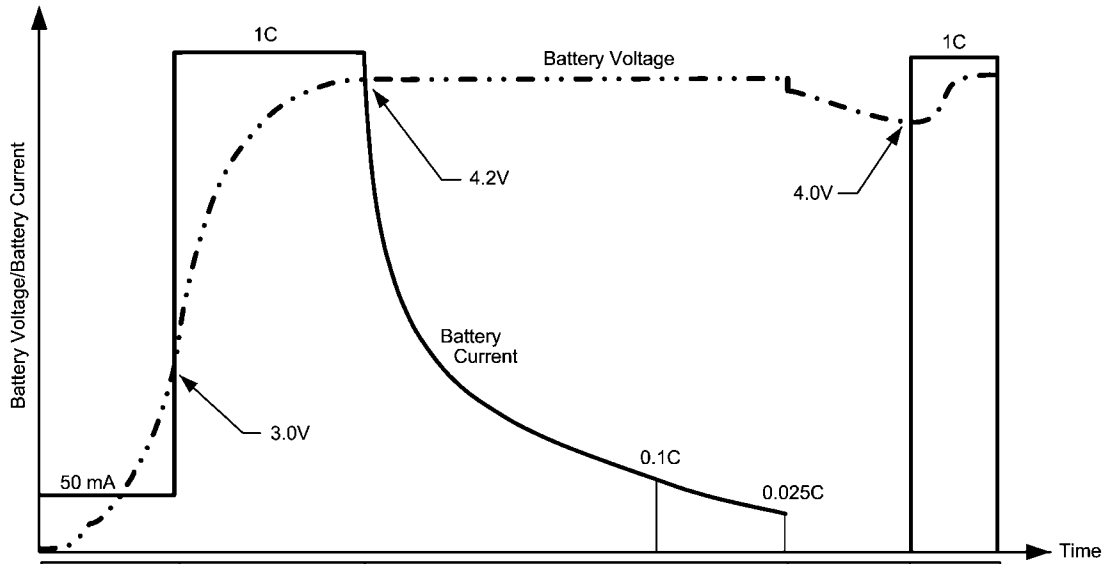

| | | | | | |
|----------------------|------------------|------------------|---------------------|-------------|------------------|
| Pre-qualification | Constant Current | Constant Voltage | | Maintenance | Constant Current |
| T _{PREQUAL} | T _{CHG} | | T _{TOPOFF} | | T _{CHG} |

| | | | | |
|-------|-----|--|-----|-----|
| STAT1 | ON | | OFF | ON |
| STAT2 | OFF | | ON | OFF |

20128204

LM3658 Operation Description

$$I_{\text{CHG}} = \frac{K_{\text{ISET}}}{R_{\text{ISET}}}$$

POWER-DOWN MODE

The LM3658 will power down automatically when the voltage on the USBpwr or CHG_IN pin drops below the battery voltage with an amount that is equal to $V_{\text{OK_CHG}}$ ($V_{\text{BATT}} > V_{\text{CC}} - V_{\text{OK_CHG}}$). Power-Down mode shuts off the internal power FETs as well as the open-drain pull-down transistors on the status pins STAT1 and STAT2. The only current consumed by the LM3658 is an ultra-low quiescent current of 1 μA typical.

POWER-ON RESET

As soon as the voltage of one of the power sources rises above $V_{\text{BATT}} + V_{\text{OK_CHG}}$, the charger will wake up. However, charging will not be initiated unless the supply voltage source exceeds the V_{POR} .

AUTOMATIC POWER SOURCE DETECTION

When the voltage of one of the power sources exceeds the V_{POR} threshold, the LM3658 detects which power source is a valid charge supply. When both supply voltages are valid and present, CHG_IN will automatically be selected over USBpwr. The USBpwr will be the designated power source only if no CHG_IN is present or when the voltage on the CHG_IN pin is less than the battery voltage.

THERMAL POWER FET REGULATION

The internal power FETs are thermally regulated to the junction temperature of 120°C to guarantee optimal charging of the battery. At all times is the charge current limited by the I_{SET} resistor setting, the USB 100 mA/500 mA selection, or the 100°C junction temperature of the LM3658. The charge current is therefore a function of the charge current settings, the thermal conductivity of the package and the ambient temperature as described in the following equation:

$$I_{\text{CHG}} = \min \left[\frac{K_{\text{ISET}}}{R_{\text{ISET}}} \text{ or } \text{USB_sel} \text{ or } \frac{120^\circ\text{C} - T_{\text{A}}}{\theta_{\text{JA}}(V_{\text{CC}} - V_{\text{BATT}})} \right]$$

20128205

Where T_{A} is the ambient temperature and θ_{JA} is the thermal resistance of the package. Thermal regulation guarantees maximum charge current and superior charge rate without exceeding the power dissipation limits of the LM3658.

PRE-QUALIFICATION MODE

During pre-qualification, STAT1 is on and STAT2 is off, and the charger supplies a constant current of 50 mA to the battery. When the battery voltage reaches $V_{\text{FULL_RATE}}$, the charger transitions from pre-qualification to full-rate charging. The pre-qualification mode aborts when the battery doesn't reach $V_{\text{FULL_RATE}}$ within the time allowed in T_{PREQUAL} timer. In this event, charging stops and STAT1 and STAT2 will both be on, indicating a bad battery condition.

CHG_IN FULL-RATE CHARGING MODE

The full-rate charge cycle is initiated following the successful completion of the pre-qualification mode. Timer T_{CHG} starts to count when the charger enters full-rate charging, with STAT1 on and STAT2 off. When charging with an AC wall adapter, the full-rate charge current is proportional to the value of the resistor that is connected to the I_{SET} pin as described in the following equation:

It is recommended to charge Li-Ion batteries at 1C rate, where "C" is the capacity of the battery. As an example, it is recommended to charge a 750 mAh battery at 750 mA, or 1C. Charging at a higher rate can cause damage to the battery.

USBpwr FULL-RATE CHARGING MODE

The full-rate charge cycle is initiated following the successful completion of the pre-qualification mode. Timer T_{CHG} starts to count when the charger enters full-rate charging, with STAT1 on and STAT2 off. If the USB bus provides the charger supply, then the default full-rate charge current is 100 mA max unless the USB_sel pin is pulled high, which sets the charge current to 500 mA max.

CONSTANT-VOLTAGE CHARGING MODE AND END-OF-CHARGE (EOC) DETECTION

The battery voltage increases rapidly as a result of full-rate charging and will reach the 4.2V termination voltage, triggering the constant-voltage charge cycle. Timer T_{CHG} continues to count in this cycle. STAT1 is on and STAT2 is off. The charge current gradually decreases during constant-voltage charging until it reaches the End-Of-Charge (EOC), which is equal to 10% of the full-rate current set either by the resistor connected to the I_{SET} pin or the USB_sel pin. If Timer T_{CHG} times out before EOC is reached, charging stops and STAT1 and STAT2 will both be on, indicating a bad battery condition.

TOP-OFF CHARGING MODE

Once EOC has been reached, a top-off cycle continues to charge the battery. Timed top-off cycle provides optimal battery capacity following a complete charge cycle. During this cycle, charging terminates when I_{CHG} reaches 2.5% of the full-rate charge current or when T_{TOPOFF} times out, whichever occurs first. STAT1 will turn off and STAT2 will turn on once the top-off cycle completes successfully, indicating that charging is done.

MAINTENANCE MODE

Maintenance mode begins immediately after the charger successfully finishes the top-off cycle. In the maintenance mode, the battery voltage is being monitored by the LM3658 continuously. If the battery voltage drops 200 mV below V_{TERM} , a new full-rate charge cycle starts to replenish the battery. As this new full-rate charge cycle begins, STAT1 will turn on and STAT2 will turn off, and all the timers will reset. Refer to the LM3658 Flowchart.

CHARGE STATUS OUTPUTS

The LM3658 provides two open-drain outputs STAT1 and STAT2 that can be connected to external LEDs or to General Purpose I/O's (GPIO) of a peripheral IC. All charge status of the LM3658 is illustrated in Table 1. "ON" means that STATx pin is pulled low as its pull-down transistor is turned on, representing a logic 0.

TABLE 1. Status Pins Summary

| STAT1 | STAT2 | Condition |
|-------|-------|--|
| OFF | OFF | Power-Down, charging is suspended or interrupted |
| ON | OFF | Pre-qualification mode, CC and CV charging, Top-off mode |
| OFF | ON | Charge is completed |
| ON | ON | Bad battery (Safety timer expired), or LDO mode |

SAFETY TIMERS

In order to prevent endless charging of the battery, which can cause damage to the battery, there are three safety timers that forcefully terminate charging if the charging mode is not completed within the time allowed.

Pre-Qualification Timer ($T_{PREQUAL}$)

The pre-qualification timer starts with the initiation of the pre-qualification mode and allows 30 minutes to transition from pre-qualification to full rate charging. If the battery voltage does not reach V_{FULL_RATE} in 30 minutes, charging stops and status pins STAT1 and STAT2 both turn on to indicate a bad battery status.

Charger Timer (T_{CHG})

The charge timer starts with the initiation of full-rate charging and has a duration of 5 hours for the LM3658. If the charge current does not reach EOC, charging stops and STAT1 and STAT2 both turn on to indicate a bad battery status. Once the charge control declares a bad battery, removing the input source is the only means to clear the bad battery status.

Top-Off Timer (T_{TOPOFF})

Once the charger successfully completes constant current constant voltage charging, it enters top-off mode and starts T_{TOPOFF} timer. Topoff lasts 30 minutes for the LM3658. During top-off, charging stops when T_{TOPOFF} reaches its count or when I_{CHG} reaches 2.5% of the full-rate charge current. There is no time-out condition in top-off mode.

When charging is interrupted either by battery temperature out of range or disabling the LM3658, the applicable safety timer will store its count value for the duration of the interruption and subsequently resumes counting from its stored count value when charging continues, only if the charger resumes to the same operation mode it was in before the interrupt.

The LM3658SD-A version has selectable timers for T_{CHG} and T_{TOPOFF} . Based on the logic level applied to the USB_sel pin, timers can be chosen as follow:

| Input | USB_SEL | $T_{PREQUAL}$ | T_{CHG} | T_{TOPOFF} |
|--------|---------|---------------|-----------|--------------|
| CHG_IN | Low | 30 minutes | 10 hours | 60 minutes |
| CHG_IN | High | 30 minutes | 5 hours | 30 minutes |
| USBpwr | Low | 30 minutes | 10 hours | 60 minutes |
| USBpwr | High | 30 minutes | 5 hours | 30 minutes |

BATTERY TEMPERATURE MONITORING (SUSPEND MODE)

The LM3658 is equipped with a battery thermistor interface to continuously monitor the battery temperature by measuring the voltage between the T_S pin and ground. Charging is allowed only if the battery temperature is within the acceptable temperature range set by a pair of internal comparators inside the LM3658. If the battery temperature is out of range, STAT1 and STAT2 both turn off and charging is suspended. Timer holds its count value.

The T_S pin is only active during charging and draws no current from the battery when no external power source is present.

If the T_S pin is not used in the application, it should be connected to GND through 10k Ω pulldown resistor.

When the T_S pin is left floating (battery removal), then the charger will be disabled as the T_S voltage exceeds the upper temperature limit.

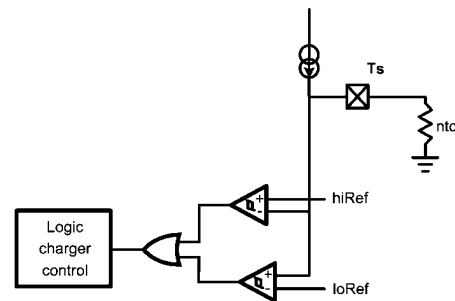

20128210

The LM3658 battery temperature feature is tailored to use negative temperature coefficient (NTC) 103AT thermistors with 10k Ω impedance. If alternative thermistors need to be used in the system, supplemental external resistors are needed to create a circuit with equivalent impedance.

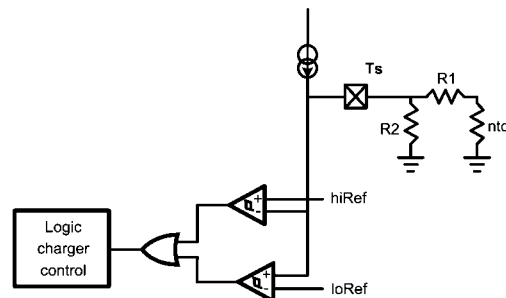

20128211

DISABLING CHARGER (CHARGE INTERRUPT MODE)

Charging can be safely interrupted by pulling the EN_b pin high and charging can resume upon pulling the EN_b pin low. The enable pin can be permanently tied to GND with no extra current consumption penalty during power down mode. When the charger is disabled, timer holds its count value, and STAT1 and STAT2 are both off.

LDO MODE (AVAILABLE ONLY IN LM3658SD-B VERSION)

The LM3658SD-B version enters LDO mode when the T_s pin is floating and AC wall adapter is still connected to CHG_IN pin. In LDO mode, STAT1 and STAT2 are both on. The LM3658SD-B becomes a linear regulator capable of delivering 1A of source current. Normally the T_s pin is connected to the thermistor from the battery pack for temperature monitoring purpose. If this pin is disconnected, the LM3658SD-B assumes that there is no battery present and will automatically invoke the LDO mode. LDO mode allows applications to operate without a battery provided that the AC wall adapter supplies power to the CHG_IN pin. The LDO mode is not possible in USB mode.

For the other versions of the LM3658, floating the T_s pin does not invoke LDO mode. Instead, it will go to suspend mode. Please refer to "Battery Temperature Monitoring" section for more detail.

5 HOUR/ 10 HOUR SELECTABLE TIMER (AVAILABLE ONLY IN LM3658SD-A VERSION)

The LM3658SD-A allows the user to select between 5 hour or 10 hour timer based on the polarity of the USB_sel pin, in both CHG_IN mode and USBpwr mode. By pulling the USB_sel pin high, the timer is set to 5 hours. In the USBpwr mode, the polarity of the USB_sel pin determines the charge current as well as the timer. In CHG_IN mode, the polarity of the USB_sel pin determines only the timer. The charge current is set by the resistor at I_{set} pin.

INPUT/OUTPUT BYPASS CAPACITORS

Care should be taken to support the stability of the charge system by connecting a 1 μ F capacitor as close as possible to the BATT pin. An input capacitor ranging from 1.0 μ F–10.0 μ F must be connected to the CHG_IN and USBpwr input pins. Low cost ceramic capacitors can be selected.

THERMAL PERFORMANCE OF THE LLP PACKAGE

The LM3658 is a monolithic device with integrated power FETs. For that reason, it is important to pay special attention to the thermal impedance of the LLP package and to the PCB layout rules in order to maximize power dissipation of the LLP package.

The LLP package is designed for enhanced thermal performance and features an exposed die attach pad at the bottom center of the package that creates a direct path to the PCB for maximum power dissipation. Compared to the traditional leaded packages where the die attach pad is embedded inside the molding compound, the LLP reduces one layer in the thermal path.

The thermal advantage of the LLP package is fully realized only when the exposed die attach pad is soldered down to a thermal land on the PCB board with thermal vias planted underneath the thermal land. Based on thermal analysis of the LLP package, the junction-to-ambient thermal resistance (θ_{JA}) can be improved by a factor of two when the die attach pad of the LLP package is soldered directly onto the PCB with thermal land and thermal vias, as opposed to an alternative with no direct soldering to a thermal land. Typical pitch and outer diameter for thermal vias are 1.27 mm and 0.33 mm respectively. Typical copper via barrel plating is 1 oz, although thicker copper may be used to further improve thermal performance. The LM3658 die attach pad is connected to the substrate of the IC and therefore, the thermal land and vias on the PCB board need to be connected to ground (GND pin). For more information on board layout techniques, refer to Application Note 1187 "Leadless Lead Frame Package (LLP)." This application note also discusses package handling, solder stencil and the assembly process.

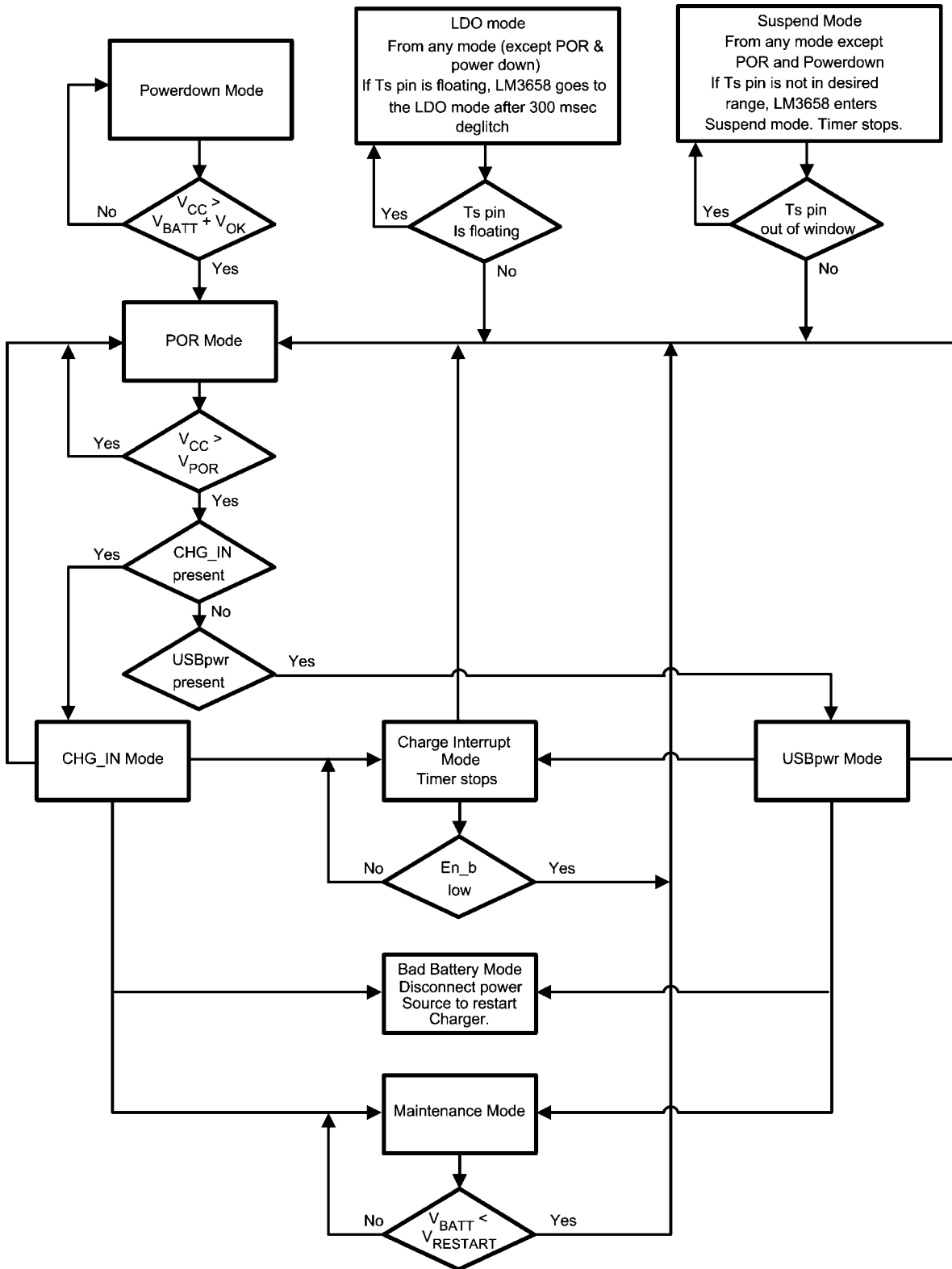

LM3658 Flowchart

20128207

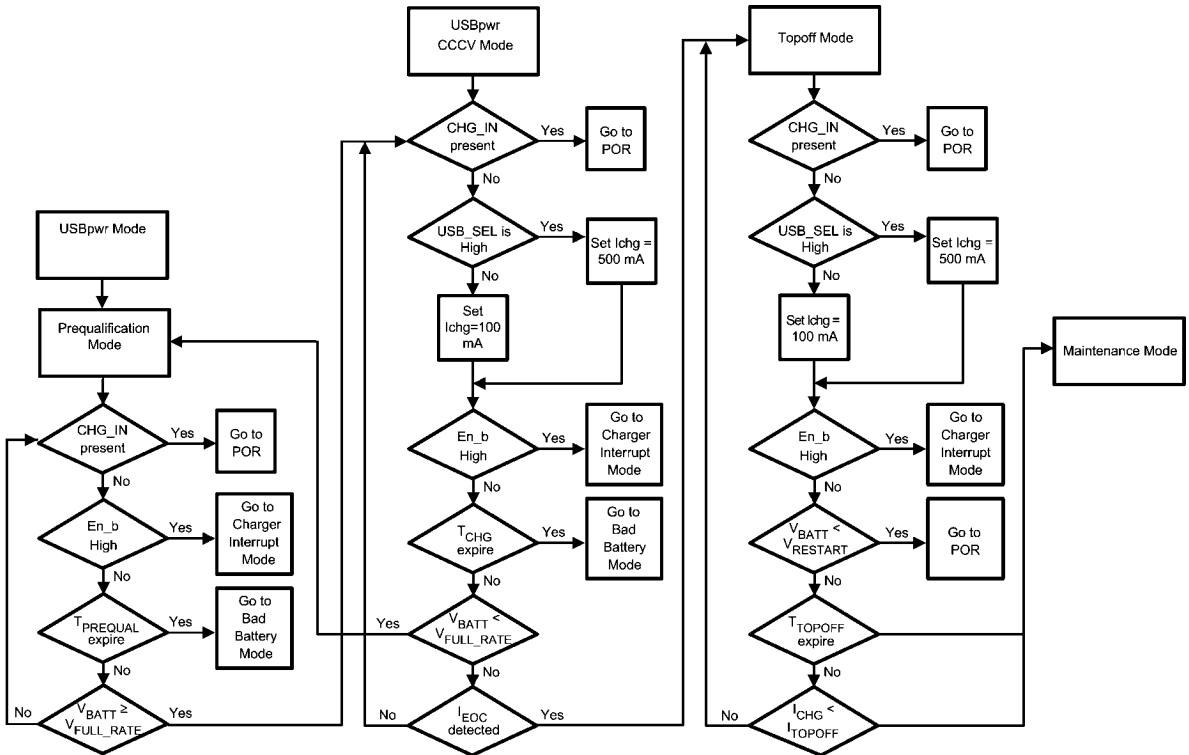

LM3658 USBpwr Mode Flowchart

20128206

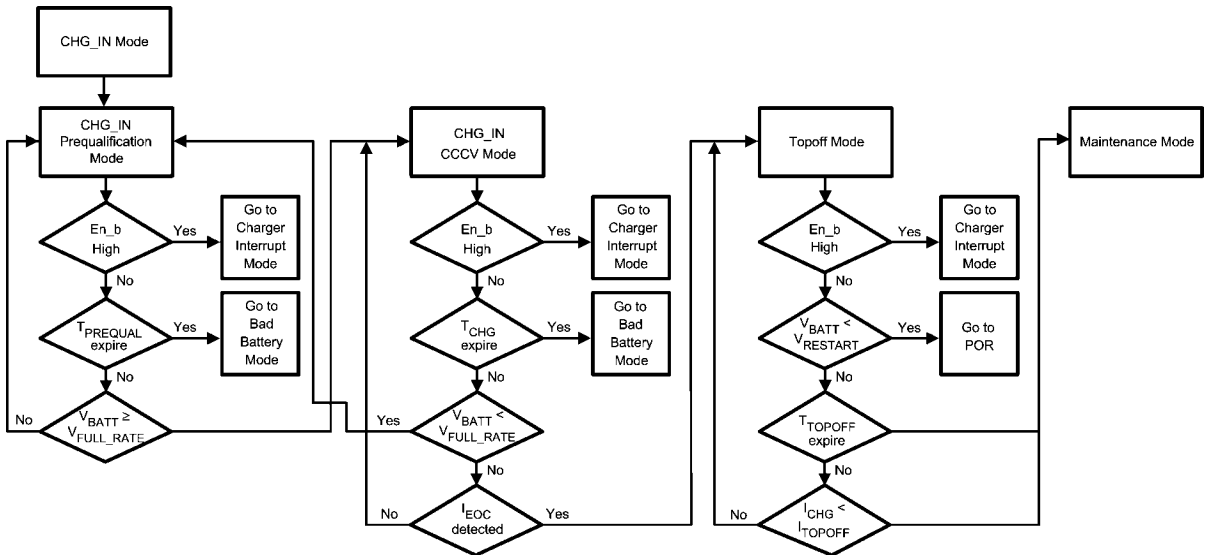

LM3658 CHG_IN Mode Flowchart

20128208

Physical Dimensions inches (millimeters) unless otherwise noted

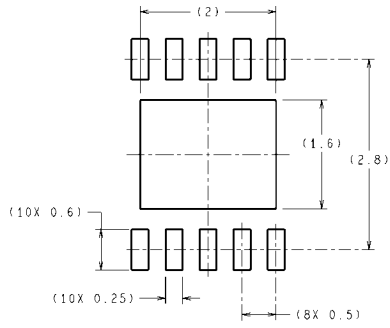

DIMENSIONS ARE IN MILLIMETERS
DIMENSIONS IN () FOR REFERENCE ONLY

RECOMMENDED LAND PATTERN

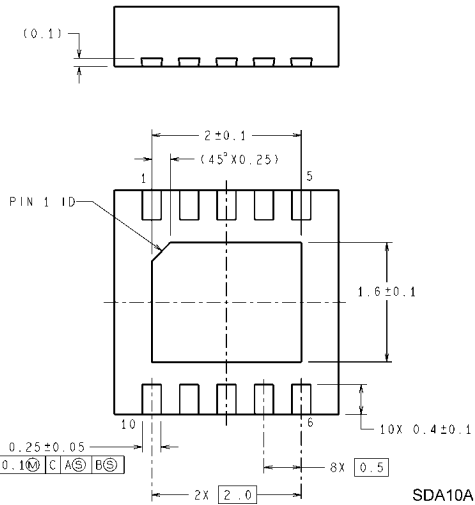
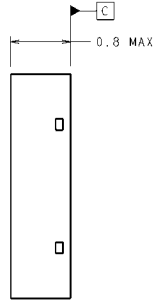
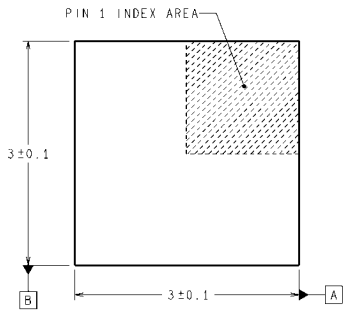

SDA10A (Rev A)

LLP10 Package Drawing
NS Package Number SDA10A

Notes

THE CONTENTS OF THIS DOCUMENT ARE PROVIDED IN CONNECTION WITH NATIONAL SEMICONDUCTOR CORPORATION ("NATIONAL") PRODUCTS. NATIONAL MAKES NO REPRESENTATIONS OR WARRANTIES WITH RESPECT TO THE ACCURACY OR COMPLETENESS OF THE CONTENTS OF THIS PUBLICATION AND RESERVES THE RIGHT TO MAKE CHANGES TO SPECIFICATIONS AND PRODUCT DESCRIPTIONS AT ANY TIME WITHOUT NOTICE. NO LICENSE, WHETHER EXPRESS, IMPLIED, ARISING BY ESTOPPEL OR OTHERWISE, TO ANY INTELLECTUAL PROPERTY RIGHTS IS GRANTED BY THIS DOCUMENT.

TESTING AND OTHER QUALITY CONTROLS ARE USED TO THE EXTENT NATIONAL DEEMS NECESSARY TO SUPPORT NATIONAL'S PRODUCT WARRANTY. EXCEPT WHERE MANDATED BY GOVERNMENT REQUIREMENTS, TESTING OF ALL PARAMETERS OF EACH PRODUCT IS NOT NECESSARILY PERFORMED. NATIONAL ASSUMES NO LIABILITY FOR APPLICATIONS ASSISTANCE OR BUYER PRODUCT DESIGN. BUYERS ARE RESPONSIBLE FOR THEIR PRODUCTS AND APPLICATIONS USING NATIONAL COMPONENTS. PRIOR TO USING OR DISTRIBUTING ANY PRODUCTS THAT INCLUDE NATIONAL COMPONENTS, BUYERS SHOULD PROVIDE ADEQUATE DESIGN, TESTING AND OPERATING SAFEGUARDS.

EXCEPT AS PROVIDED IN NATIONAL'S TERMS AND CONDITIONS OF SALE FOR SUCH PRODUCTS, NATIONAL ASSUMES NO LIABILITY WHATSOEVER, AND NATIONAL DISCLAIMS ANY EXPRESS OR IMPLIED WARRANTY RELATING TO THE SALE AND/OR USE OF NATIONAL PRODUCTS INCLUDING LIABILITY OR WARRANTIES RELATING TO FITNESS FOR A PARTICULAR PURPOSE, MERCHANTABILITY, OR INFRINGEMENT OF ANY PATENT, COPYRIGHT OR OTHER INTELLECTUAL PROPERTY RIGHT.

LIFE SUPPORT POLICY

NATIONAL'S PRODUCTS ARE NOT AUTHORIZED FOR USE AS CRITICAL COMPONENTS IN LIFE SUPPORT DEVICES OR SYSTEMS WITHOUT THE EXPRESS PRIOR WRITTEN APPROVAL OF THE CHIEF EXECUTIVE OFFICER AND GENERAL COUNSEL OF NATIONAL SEMICONDUCTOR CORPORATION. As used herein:

Life support devices or systems are devices which (a) are intended for surgical implant into the body, or (b) support or sustain life and whose failure to perform when properly used in accordance with instructions for use provided in the labeling can be reasonably expected to result in a significant injury to the user. A critical component is any component in a life support device or system whose failure to perform can be reasonably expected to cause the failure of the life support device or system or to affect its safety or effectiveness.

National Semiconductor and the National Semiconductor logo are registered trademarks of National Semiconductor Corporation. All other brand or product names may be trademarks or registered trademarks of their respective holders.

Copyright© 2007 National Semiconductor Corporation

For the most current product information visit us at www.national.com



National Semiconductor Americas Customer Support Center
 Email: new.feedback@nsc.com
 Tel: 1-800-272-9959

National Semiconductor Europe Customer Support Center
 Fax: +49 (0) 180-530-85-86
 Email: europe.support@nsc.com
 Deutsch Tel: +49 (0) 69 9508 6208
 English Tel: +49 (0) 870 24 0 2171
 Français Tel: +33 (0) 1 41 91 8790

National Semiconductor Asia Pacific Customer Support Center
 Email: ap.support@nsc.com

National Semiconductor Japan Customer Support Center
 Fax: 81-3-5639-7507
 Email: jpn.feedback@nsc.com
 Tel: 81-3-5639-7560