

ELECTRICAL

Contact Type: Form B
 Contact Rating: 5 W Max.
 Voltage, Switching: 175 V DC Max.
 120 V AC RMS Max.
 Voltage, Breakdown: 200 V DC Min.
 Current, Switching: .25 A DC Max.
 .25 A AC RMS Max.
 Current, Carry: .60 A DC Max.
 .40 A AC RMS Max.
 Contact Resistance, Initial: .220 Ohm Max.
 (Including Leads)

PHYSICAL

Capsule: Black UL94V-0 Polyester
 Encapsulant: Black Epoxy
 Leads: 24 AWG UL1569 Black
 Actuator: 57145-000
 Actuate Distance: .225 [5.72] Min.
 Deactuate Distance: .800 [20.23] Max.

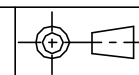
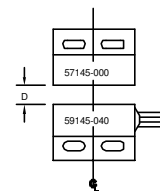

IDENTIFICATION

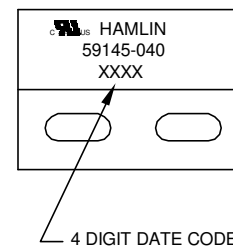
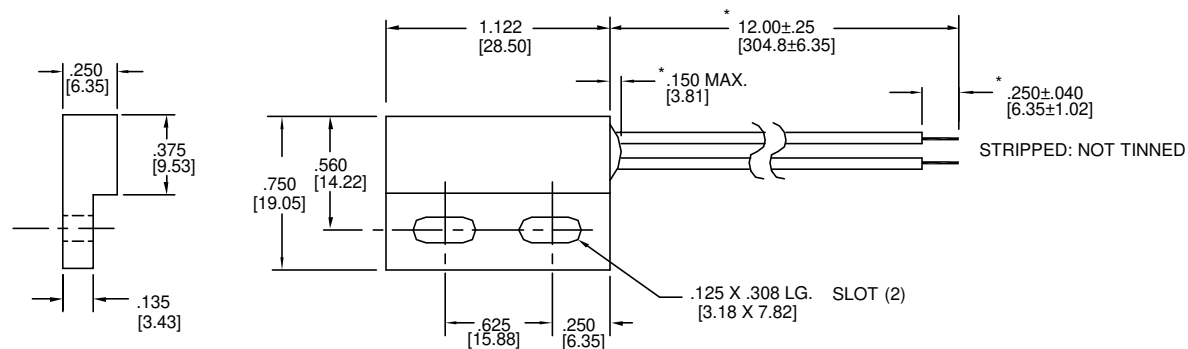

Dimensions are in Inches [mm]
 Tolerances unless otherwise noted:
 .X: ±.015, .XX: ±.010, .XXX: ±.005, Angular: ±1/2°
 * Denotes Critical Assembly Dimensions

ORIGINAL DCR NO. 1315		HAMLIN	PROPRIETARY NOTE: THE INFORMATION ON THIS DRAWING IS THE CONFIDENTIAL PROPERTY OF HAMLIN. THIS DRAWING MUST NOT BE MADE PUBLIC OR COPIED UNLESS AUTHORIZED IN WRITING BY HAMLIN. THIS DRAWING IS SUBJECT TO RETURN UPON DEMAND.	SHEET 1 of 1	DCR NO. L1629	REV. AJ
DRAWN BY: DRR	DATE: 6/27/88			DESCRIPTION OF REVISION: UPDATE DRAWING FORMAT, ADD SOLDER LEAD-FREE WIRE, ADD CAPSULE P/N		
APP'D BY: DRR	DATE: 10/3/88				APP'D BY: CRM	DATE: 29-Jun-06