

TLE 6710Q

Combined Power Supply and Firing IC



THE TLE 6710Q is a combined power supply and firing IC specially designed for automotive restraint applications. The device, located in the ECU (Electronic Control Unit) of the airbag system, incorporates several system functions in one single package.

Applications

- Automotive Restraint Applications

Features

- Boost Converter up to 30 V
- Buck Converter 5 V
- 4 independent firing loops (1.75 A ... 3 A)
- Extra HW lines (Safety Lines) to enable firing
- High Side and Low Side Switch for each firing circuit
- Digital output for firing current detection
- Watchdog for supervision
- Power on/off reset generator
- Serial interface line driver (ISO 9141 and TTL-Level)
- 4 voltage/current sources for diagnostic purposes
- Diagnostic driver for inductive loads or lamps
- Unidirectional Serial Peripheral Interface (SPI) up to 4 MHz
- Logic and analogue output for direct sensing and diagnostic via μ C

Embedded Protection Functions

- Thermal and short circuit protection for each switch
- Current limitation for each firing loop

Embedded Diagnostic Functions

- Squib resistance Measurement with programmable gain
- Programmable Squib Leakage Measurement to GND or BAT
- Detection of safing sensor closure
- Low battery detection
- Average Chip Temperature Measurement
- Supply voltage measurement on external pins

www.infineon.com/restraint-system-IC

Automotive Power



Never stop thinking

Product Brief

Block Diagram

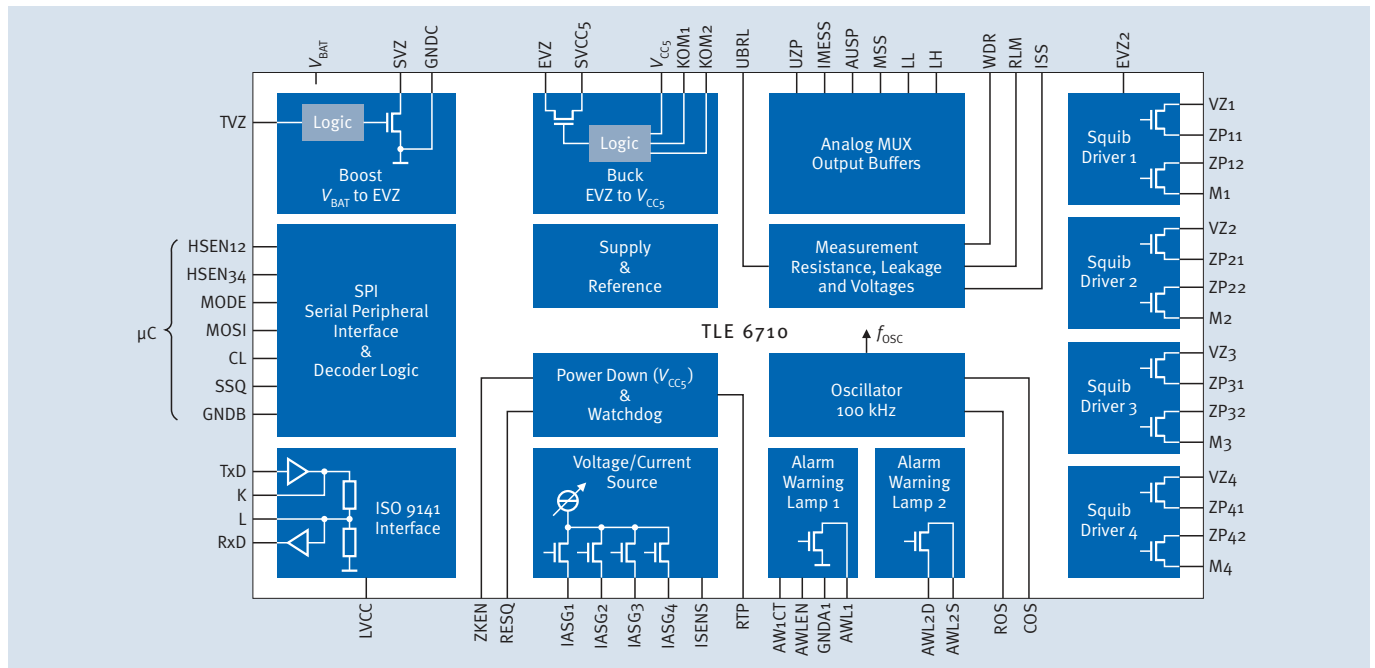

Product Summary

Type	Sales Code	Description	Package
TLE 6710Q	available upon request	Airbag System IC	P-MQFP-64-11

System Overview

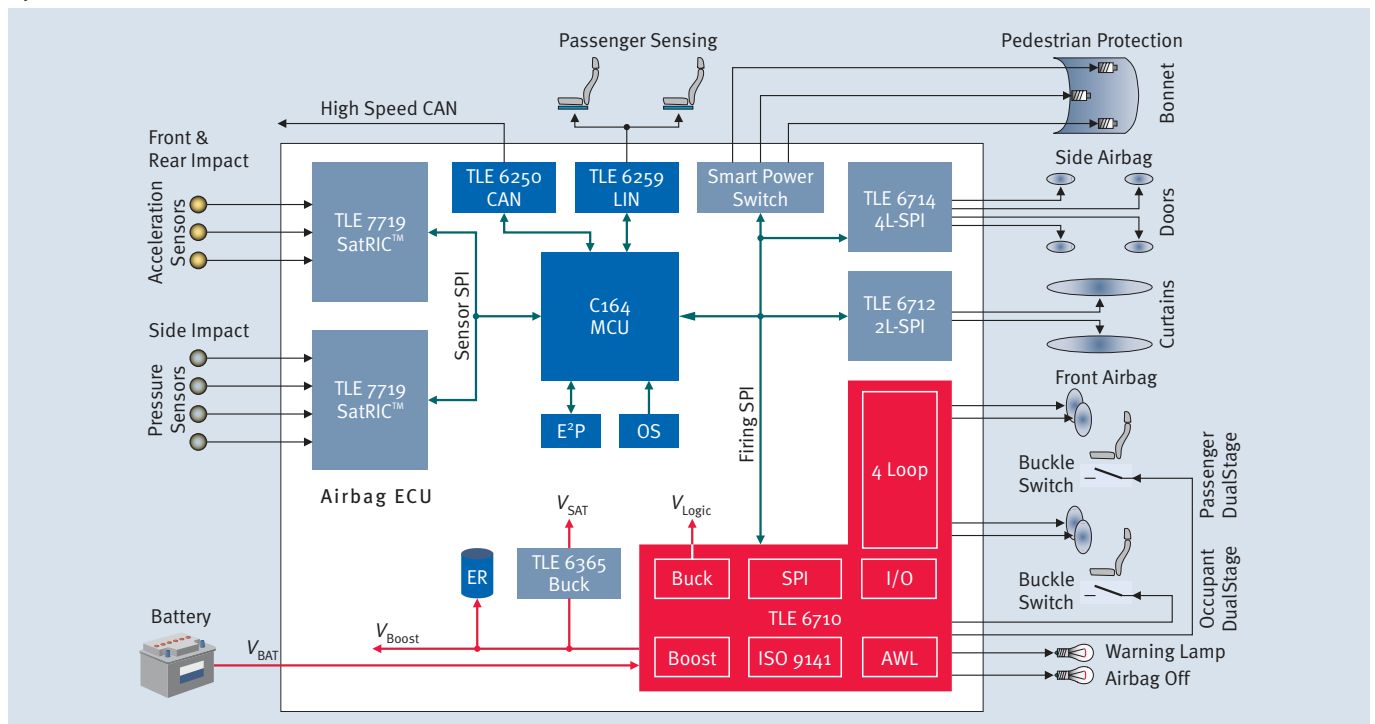

How to reach us:
<http://www.infineon.com>

Published by
 Infineon Technologies AG
 81726 Munich, Germany

© Infineon Technologies AG 2006.
 All Rights Reserved.

Legal Disclaimer

The information given in this Product Brief shall in no event be regarded as a guarantee of conditions or characteristics ("Beschaffenheitsgarantie"). With respect to any examples or hints given herein, any typical values stated herein and/or any information regarding the application of the device, Infineon Technologies hereby disclaims any and all warranties and liabilities of any kind, including without limitation warranties of non-infringement of intellectual property rights of any third party.

Information

For further information on technology, delivery terms and conditions and prices please contact your nearest Infineon Technologies Office (www.infineon.com).

Warnings

Due to technical requirements components may contain dangerous substances. For information on the types in question please contact your nearest Infineon Technologies Office. Infineon Technologies Components may only be used in life-support devices or systems with the express written approval of Infineon Technologies, if a failure of such components can reasonably be expected to cause the failure of that life-support device or system, or to affect the safety or effectiveness of that device or system. Life support devices or systems are intended to be implanted in the human body, or to support and/or maintain and sustain and/or protect human life. If they fail, it is reasonable to assume that the health of the user or other persons may be endangered.

Ordering No. B152-H8515-X-X-7600
 Printed in Germany
 PS 1106.5 nb