

NOTES:

1. MATERIALS AND FINISHES:
 BODY, BULLET CONTACT, LOCK WASHER & HEX NUT - BRASS, GOLD PLATING
 CONTACT - BeCu, GOLD PLATING
 FERRULE - COPPER, GOLD PLATING
 INSULATOR - PTFE, NATURAL
 GASKET & O-RING - SILICONE RUBBER, RED
2. ELECTRICAL:
 A. IMPEDANCE: 50 OHM
 B. FREQUENCY: DC - 7.1 GHz
 C. VSWR: 1.20 MAX. DC - 3 GHz
 1.30 MAX. 3 - 7.1 GHz
 D. DIELECTRIC WITHSTANDING VOLTAGE: 500 VRMS, MIN.
3. MECHANICAL:
 A. DURABILITY: 500 CYCLES MIN.
 B. TEMPERATURE RANGE: -65°C TO +165°C
 C. SEALING: MEETS IP-67 REQUIREMENTS IN UNMATED CONDITION

4. PACKAGING:
 A. QUANTITY: SINGLE PACK
 B. MARKING: PACKAGING TO BE MARKED
 "AMPHENOL RF, 901-10803 & DATE CODE"
 C. BULLET CONTACT AND FERRULE ARE PACKAGED LOOSE.
5. CABLE ASSEMBLY INSTRUCTIONS:
 A. TRIM CABLE AS SHOWN.
 B. SLIDE FERRULE ONTO CABLE.
 C. SOLDER CABLE CENTER CONDUCTOR TO BULLET CONTACT.
 D. INSERT CABLE WITH FOIL ENTERING CONNECTOR AND BRAID OVER KNURL.
 E. CRIMP FERRULE OVER BRAID WITH .110" HEX.

6. SHOWS CABLE ENTRY DIMENSIONS.

REVISIONS				
REV	DESCRIPTION	DATE	ECN	BY
A	RELEASE TO MFG.	11-OCT-22	16443	SH

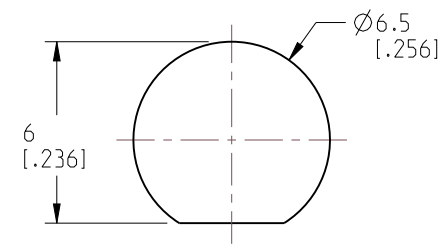

RECOMMENDED MOUNTING HOLE DIMENSIONS

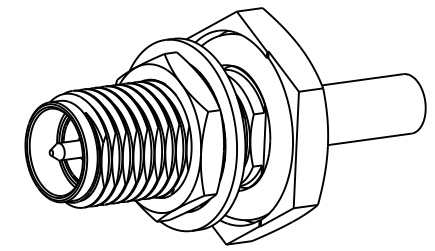

SCALE 2.500

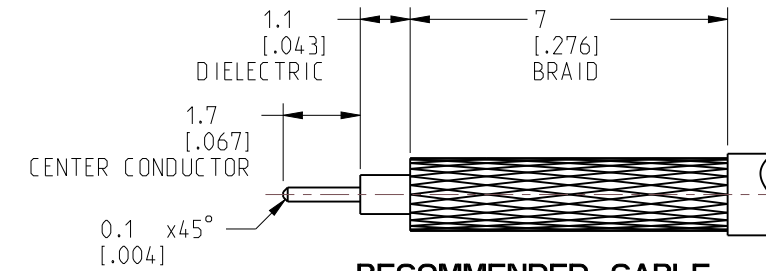

RECOMMENDED CABLE STRIPPING DIMENSIONS

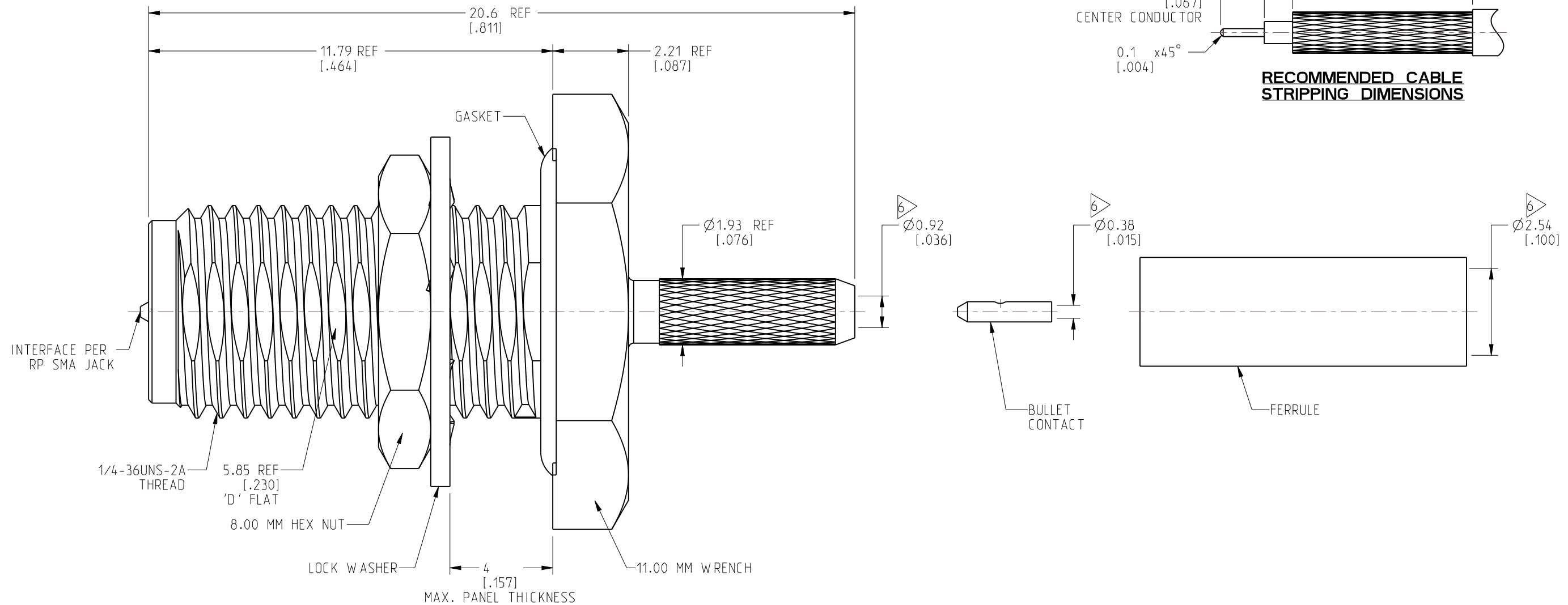

CUSTOMER OUTLINE DRAWING

ALL OTHER SHEETS ARE FOR INTERNAL USE ONLY

NOTICE: These drawings, specifications, or other data (1) are, and remain the property of Amphenol corp. (2) must be returned upon request; and (3) are confidential and not to be disclosed to any person other than those to whom they are given by Amphenol Corp. The furnishing of these drawings, specifications, or other data by Amphenol Corp., or to any other person to anyone for any purpose is not to be regarded by implication or otherwise in any manner licensing, granting rights to permitting such holder or any other person to manufacture, use or sell any product, process or design, patented or otherwise, that may in any way be related to or disclosed by said drawings, specifications, or other data.		UNLESS OTHERWISE SPECIFIED DIMENSIONS ARE METRIC (INCHES) AND TOLERANCES ARE: <0.5mm = ±0.05mm [-0.020 = ±0.002] >0.5 - 6mm = ±0.1mm [-0.020 - 0.236 = ±0.004] >6.00 - 30mm = ±0.2mm [-0.236 - 1.181 = ±0.008] >30.00 - 120mm = ±0.3mm [-1.181 - 4.725 = ±0.012]		MATERIAL SEE NOTES		TITLE RP SMA STR BHD JACK IP 67 FOR RG 178 CABLE		Amphenol RF	
THIRD ANGLE PROJ.		REFERENCE		ENGR.1 KRISHNA S		ENGR.2 JACK LIANG		DATE 09-ARP-21	
EAR# 10155		ANGLES = ±1°		SHEET NO. 2 OF 2		SCALE: 8.0:1.0		DRAWING NO. 901-10803 ITEM NO. 901-10803 PART NO. 901-10803	
SIZE B		REV A		5		4		3	