



MAX3535E Evaluation Kit

Evaluates: MAX3535E

General Description

The MAX3535E evaluation kit (EV kit) is a fully assembled and tested PCB that contains a 2500V_{RMS} isolated RS-485/RS-422 transceiver with ESD protection. The EV kit circuit features a differential driver and one receiver. The circuit's receiver is a 1/8 unit load for the RS-485 bus and communicates up to 1000kbps. The MAX3535E fail-safe circuitry and driver slew-rate features are demonstrated and easily reconfigured.

Additionally, the EV kit features an H-bridge DC-DC converter to power the isolated section of the MAX3535E RS-485/RS-422 circuit. Input power to the circuit is supplied by a +3V to +5.5VDC source. This circuit uses a full-wave rectifier on the unregulated output and provides unregulated voltage to the MAX3535E internal, linear low-dropout (LDO) regulator. Using an H-bridge design minimizes input ripple current and radiated noise. Undervoltage lockout (UVLO) and thermal shutdown provide for a robust, isolated RS-485/RS-422 transceiver circuit and power supply. The surface-mount transformer provides up to 2500V_{RMS} galvanic isolation and the output is powered from a center-tapped, full-wave rectifier circuit to reduce output voltage ripple.

The isolated H-bridge DC-DC converter operation at 420kHz allows the use of ceramic-only output capacitors and a small transformer.

Features

- ◆ Designed for 2500V_{RMS} Isolation
- ◆ 1/8 RS-485 Unit Load
- ◆ 1000kbps Full-Duplex RS-485/RS-422 Communication (Configurable for Half Duplex)
- ◆ +3.0V to +5.5VDC Input Range
- ◆ Isolated V_{CC2} Output
- ◆ Center-Tapped, Full-Wave Rectifier Output
- ◆ 420kHz Switching Frequency
- ◆ Undervoltage Lockout (UVLO) and Thermal Shutdown
- ◆ Low-Cost Integrated-FET H-Bridge Design
- ◆ Fully Assembled and Tested

Component List

DESIGNATION	QTY	DESCRIPTION
C1, C3	2	10μF ±10%, 10V X7R ceramic capacitors (1206) Murata GRM31CR71A106K
C2, C4	2	0.1μF ±10%, 25V X7R ceramic capacitors (0805) Murata GRM21BR71E104K
D1	1	30V, 200mA Schottky diode (SOT-23) Central Semiconductor CBAT54C
JU1	1	3-pin header
JU2, JU3, JU4	3	2-pin headers
R1, R2	0	Not installed, resistors (0805) 10kΩ ±1% resistor recommended
R3, R4	2	100kΩ ±5% resistors (0805)
T1	1	500μH, 3kV _{RMS} 1CT:1:33CT turns transformer (6 pin) HALO Electronics TGMR-340NA5RL
U1	1	MAX3535EEWI+ (28-pin Wide SO)
—	4	Shunts (JU1–JU4)
—	4	Rubber bumpers
—	1	PCB: MAX3535EEVKIT+

Ordering Information

PART	TEMP RANGE	IC PACKAGE
MAX3535EEVKIT+	0°C to +70°C*	28 Wide SO

+Denotes a lead-free and RoHS-compliant EV Kit.

*This limited temperature range applies to the EV kit PCB only. The MAX3535E IC temperature range is -40°C to +85°C.

Component Suppliers

SUPPLIER	PHONE	WEBSITE
Central Semiconductor	631-435-1110	www.centalsemi.com
HALO Electronics	650-903-3800	www.haloelectronics.com
Murata Mfg. Co., Ltd.	770-436-1300	www.murata.com

Note: Indicate that you are using the MAX3535E when contacting these component suppliers.



MAX3535E Evaluation Kit

Quick Start

Required Equipment

- One 5V, 1A current-limited power supply with built-in current meter
- One voltmeter
- One logic signal generator
- One oscilloscope

Procedure

The MAX3535E EV kit is fully assembled and tested. Follow the steps below to verify board operation.

Caution: Do not turn on the power supply until all connections are completed.

- 1) Connect a voltmeter to the VCC2 and SGND PC pads.
- 2) Verify that a shunt is installed across pins 2-3 of jumper JU1 (receiver enabled).
- 3) Verify that a shunt is not installed across the pins of jumper JU2 (fast slew rate).
- 4) Verify that a shunt is installed across the pins of jumpers JU3 and JU4 (half duplex).
- 5) Connect the +5V power supply to the VCC1 pad. Connect the power supply's ground to the GND pad.
- 6) Turn on the power supply and verify that the voltmeter at VCC2 reads over +5V.
- 7) Apply a logic signal to the DI PCB pad and GND. Using an oscilloscope, verify the signal at the A-B, RO2, and RO1 output pads.

The +5V supply powering the MAX3535E EV kit must be current limited at 1A.

Detailed Description

The EV kit features a MAX3535E IC in a 28-pin wide SO surface-mount package and demonstrates the MAX3535E 2500V_{RMS} isolated RS-485/RS-422 transceiver with ESD protection. The circuit's differential driver and receiver are configurable for full- or half-duplex operation and can communicate up to 1000kbps. The circuit is a 1/8 unit load on the receiver's bus.

The EV kit features PCB pads to ease interfacing with logic signals for the driver and receiver signals. On the nonisolated side, the DI pad is the driver input pad and the RO1 pad is the receiver-signal output pad. Resistor R3 pulls the DI pad up to VCC1, and resistor R4 pulls the DE pad up to VCC1. On the isolated side, the RO2 pad is the receiver output.

The MAX3535E fail-safe circuitry signals are also provided on the RO1 (receiver output) and RO2 (isolated receiver output) PC pads. Either pad gives a logic-high if A-B is > -10mV, or if A-B floats or shorts. A logic-low is given if A-B is < -200mV. Refer to the *Fail Safe* section and *Table 3* in the MAX3535E IC data sheet for additional information on the fail-safe circuitry and operation.

The circuit's input power is typically a +5VDC source, or is operated from a +3V to +5.5VDC source with a corresponding reduction in the output voltage on the isolated side. The EV kit circuit's DC source must provide at least 350mA of current, but can also be operated at lower voltages consistent with the UVLO limit.

The MAX3535E integrates a primary-side controller and H-bridge drivers. The device contains an on-board oscillator, protection circuitry, and internal FET drivers to provide up to 500mW of power to the primary of transformer T1.

The MAX3535E driver slew rate is reconfigured using jumper JU2 on the EV kit. The slew rate can be configured for 400kbps (slow) operation to minimize EMI radiation or 1000kbps (fast). See the *Slew-Rate Selection* section for configuring the slew rate.

The circuit's H-bridge DC-DC converter powers the MAX3535E isolated section of the circuit. One of the benefits of the easy-to-use H-bridge DC-DC converter topology is minimized input ripple current, and radiated noise by the inherent balanced nature of the design, with no interruption in the input current. UVLO and thermal shutdown provide for a robust isolated supply. Thermal-shutdown circuitry provides additional protection against damage due to overtemperature conditions. The MAX3535E IC's UVLO provides controlled turn-on while powering up and during brownouts.

The surface-mount transformer provides up to 2500V_{RMS} galvanic isolation and the output is powered from a center-tapped, full-wave rectifier circuit to reduce output voltage ripple. The isolated H-bridge DC-DC converter operation at 420kHz allows the use of ceramic-only output capacitors and a small transformer. The switching-frequency duty cycle is fixed at 50% to control energy transfer to the isolated output and to prevent DC current flow in the transformer.

The PCB is designed for 2500V isolation with 300 mils spacing between the GND and SGND planes. Test points TP1 (GND) and TP2 (SGND) are provided on the PCB for probing the respective ground plane, or to connect the GND to SGND planes for nonisolated evaluation of the circuit.

MAX3535E Evaluation Kit

Evaluates: MAX3535E

Jumper Selection

The MAX3535E EV kit features several jumpers to reconfigure the circuit's receiver/driver enable circuits, slew-rate control, and full- or half-duplex operation. Additionally, PCB pads are provided for connecting an external load to the isolated output at V_{CC2} and SGND.

Driver and Receiver Enable Selection

The MAX3535E EV kit features a 3-pin jumper (JU1) to set the MAX3535E driver and receiver output-enable modes. Table 1 lists the jumper options for the various modes of operation. Refer to the MAX3535E IC data sheet for more information on the MAX3535E DE and \overline{RE} pin's driver/receiver modes of operation. See Table 3 for configuring the MAX3535E communication mode.

Slew-Rate Selection

The MAX3535E EV kit features a 2-pin jumper (JU2) to set the MAX3535E communication slew rate. Table 2 lists jumper options for configuring the slew rate that will affect the maximum data rate. Refer to the MAX3535E IC data sheet for more information on the slew-rate configuration.

Full-/Half-Duplex Communication Configuration

The MAX3535E EV kit features two jumpers that set the communication mode of operation (full duplex or half duplex). Jumpers JU3 and JU4 configure the circuit for the mode (see Table 3 for configuration options). See Table 2 for reconfiguring the communication slew rate, which also impacts the maximum communication speed; see Table 1 for configuring the MAX3535E receiver and driver modes of operation.

Resistors R1 and R2 Configuration

Pads are provided for pullup and pulldown resistors for the A-B lines, although the use of these resistors is purely optional. Pullup and pulldown resistors are used on the receiver inputs to guarantee a known state in the event that all nodes on the bus are in receive mode, or the cable becomes disconnected. The exact value for these resistors varies with the application. For example, a cable that is doubly terminated with 120Ω resistors may use 750Ω, while an unterminated cable may use 10kΩ. These resistors are not required because the MAX3535E has a fail-safe receiver designed to guarantee a high output in the event a cable disconnects or shorts between A-B. Use surface-mount 0805 case-size resistors for R1 and R2.

Evaluating Other Transformer Configurations/Designs

Evaluating the HALO TGM-350NA Transformer

Use the layout of the MAX3535E EV kit to evaluate other

Table 1. Driver and Receiver Functions (JU1)

SHUNT LOCATION	DE PIN	\overline{RE} PIN	MAX3535E DRIVER/RECEIVER MODE
1-2	Connected to \overline{RE} and R4 pulled up to V _{CC1}	Connected to DE and pulled up to V _{CC1} by R4	Driver is enabled, receiver is disabled and vice versa.
2-3* (default)	Connected to DE PC pad and R4 pulled up to V _{CC1}	Connected to GND	Receiver is always on and driver is enabled with the DE signal.
None*	Connected to DE PC pad and R4 pulled up to V _{CC1}	Connected to \overline{RE} PC pad only	Independent control of driver- and receiver-enable states.

*To avoid bus contention, ensure that only one driver has control of the bus.

Table 2. Slew-Rate Functions (JU2)

SHUNT LOCATION	\overline{SLO} PIN	SLEW-RATE (DATA RATE)
None	Not connected	Fast (up to 1000kbps)
Installed	Connected to SGND	Slow (up to 400kbps)

Table 3. Communication Mode Functions (JU3 and JU4)

JU3 SHUNT LOCATION	JU4 SHUNT LOCATION	COMMUNICATION MODE
Installed	Installed	Half duplex
None	None	Full duplex

pin-for-pin transformer replacements for the TGM-340, provided with the EV kit. For example, the TGM-350, which has a 1:1 turns ratio and lowers the primary current consumption, can be used in place of the default transformer that has a 3:4 turns ratio. The lower turns ratio causes the circuit to have a lower output voltage, while being able to supply slightly more current. This lower output voltage implies an increase of the lower bound for the input-supply voltage. When used with the TGM-350 transformer, the input-supply voltage range is

MAX3535E Evaluation Kit

reduced to +3.6V to +5.5V. Other changes to the transformer turns ratio may be possible to suit the exact needs of the application. Refer to the MAX3535E IC data sheet for more information. Contact HALO Electronics to obtain a TGM-350NA transformer.

Smaller Transformer and 2kV Isolation Design

The transformer (T1) is an integral part of the dielectric-withstand voltage of the EV kit circuit. The MAX3535E IC is guaranteed to withstand 2500V_{RMS} for one minute

(min). However, the circuit uses an isolated transformer to transfer power from the primary side to the secondary side. The withstand voltage of the transformer, as well as the MAX3535E, must be considered when designing and testing the EV kit circuit. For example, if less than 3kV isolation is needed, a smaller 2kV transformer can be used to save board area, but the entire circuit will have only 2kV of isolation.

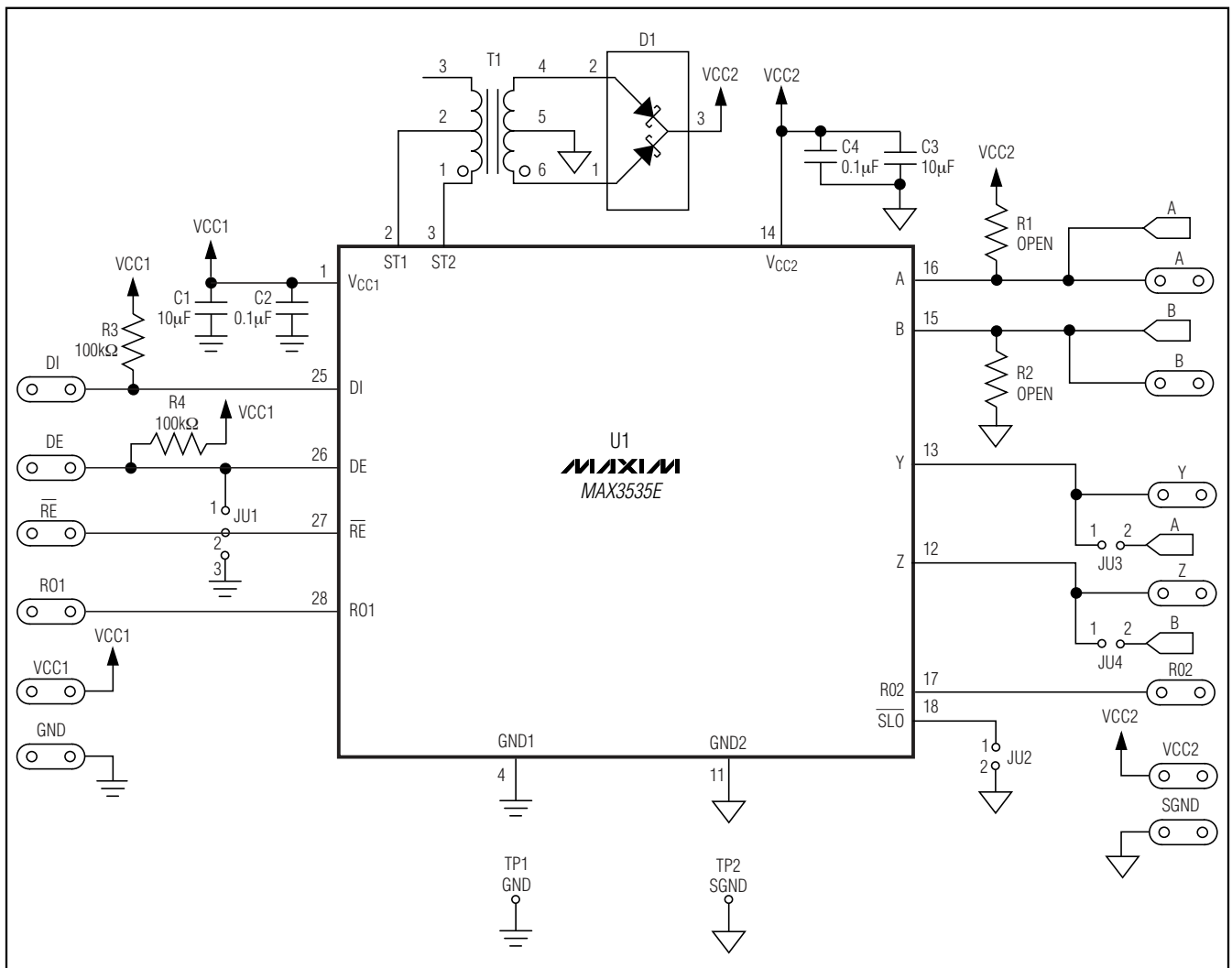

Figure 1. MAX3535E EV Kit Schematic

MAX3535E Evaluation Kit

Evaluates: MAX3535E

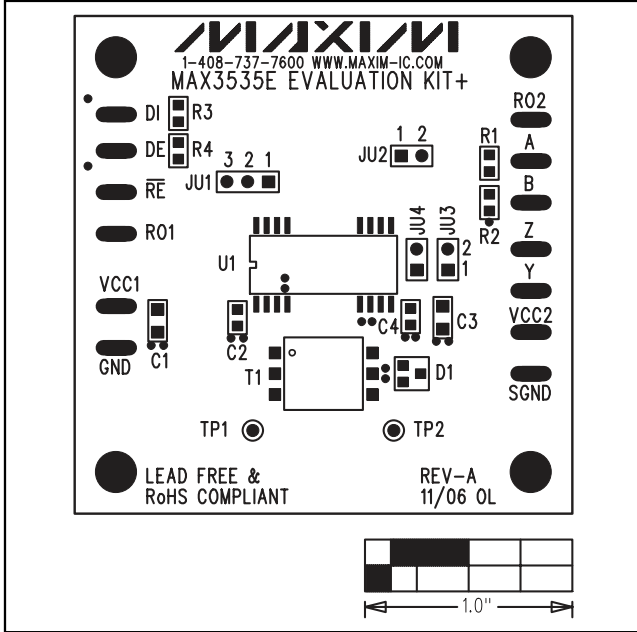

Figure 2. MAX3535E EV Kit Component Placement Guide—Component Side

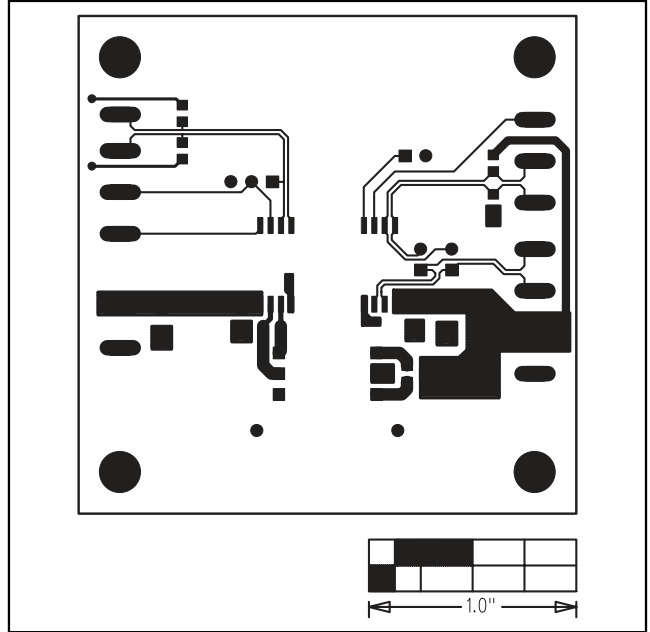

Figure 3. MAX3535E EV Kit PCB Layout—Component Side

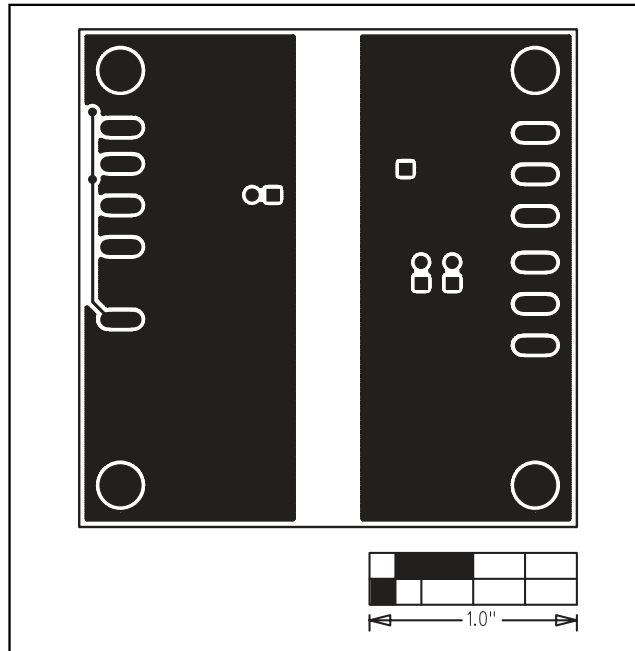

Figure 4. MAX3535E EV Kit PCB Layout—Solder Side

Maxim cannot assume responsibility for use of any circuitry other than circuitry entirely embodied in a Maxim product. No circuit patent licenses are implied. Maxim reserves the right to change the circuitry and specifications without notice at any time.

Maxim Integrated Products, 120 San Gabriel Drive, Sunnyvale, CA 94086 408-737-7600 _____ 5