

DRAWING MADE IN THIRD ANGLE PROJECTION

© COPYRIGHT 1973 BY AMP INCORPORATED, HARRISBURG, PA. ALL INTERNATIONAL RIGHTS RESERVED. AMP INCORPORATED PRODUCTS COVERED BY U. S. AND FOREIGN PATENTS AND/OR PATENTS PENDING.



SHEET METAL SCREWS NOT SUPPLIED. TWO REQUIRED PER CONNECTOR. FOR USE WITH 2,3 & 4 CIRCUIT HOUSINGS WITH A MAXIMUM WIRE BUNDLE DIAMETER OF 5/16".

REVISIONS						
P	F	ZONE	LTR	DESCRIPTION	DATE	APPROVED
	✓		D	REDRAWN + ADDED 3 VIEW ORTHOGRAPHIC PROJECTION M-5661	2-14-80	MSF/D.K.
	✓		D ₁	RESTORED	12-7-84	RPH/RS
	✓		E	OBSOLETE -2,-3,-4,-5,-6,-7,-8,-9 PER CM-473	4-15-86	KW/RS
	✓		F	OBSOLETE -1 PER CM-930	6-6-88	PH/RS
	✓		G	REV PER ECN CM-3828	8-3-92	NJG/RS

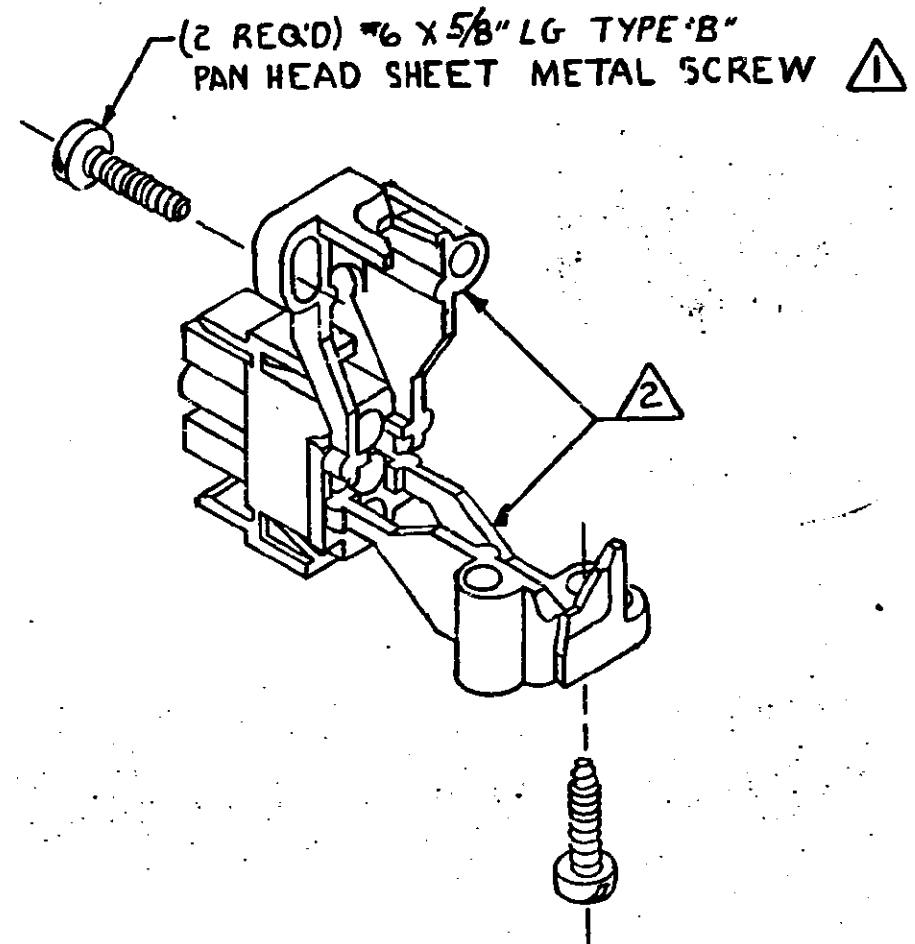
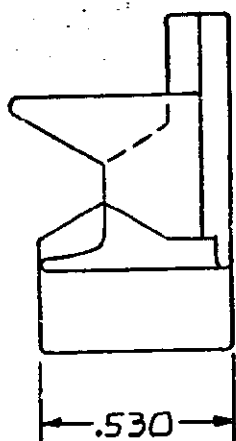
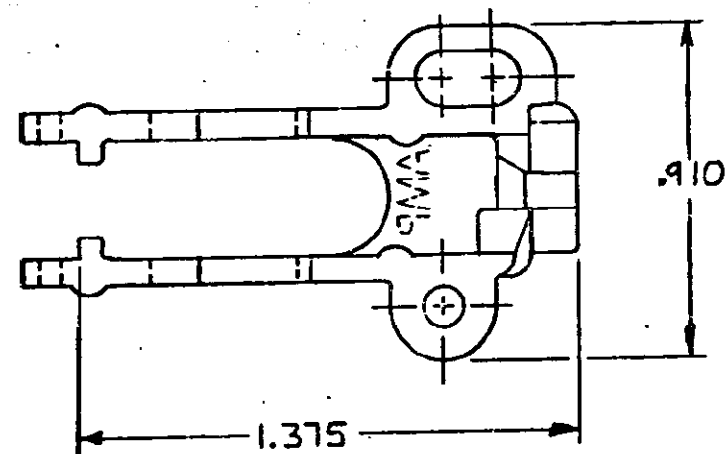
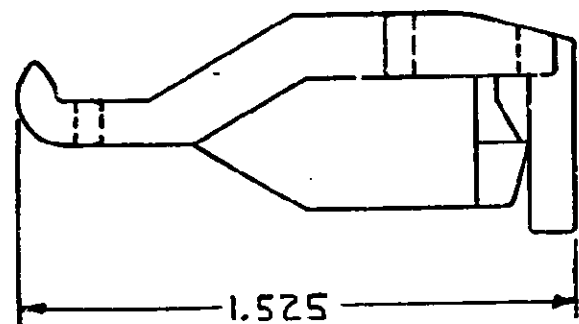

COLOR	MATERIAL	PART NO
NATURAL	NYLON 94 V-2	1-350589-0

UNLESS OTHERWISE SPECIFIED DIMENSIONS ARE IN INCHES. TOLERANCES ON: DECIMALS ± .015 ANGLES ±	CONTRACT NO	AMP INCORPORATED Harrisburg, Pa.		
	CHK	NAME		
	APPD	STRAIN RELIEF FOR UNIVERSAL MATE-N-LOK™ HOUSING		
	APPD	SIZE	CODE IDENT NO	DRAWING NO
MATERIAL	DSGN APPD	C	00779	350589
SEE TABLE	OTHER APPD	SCALE	2-1	SHEET
FINISH				
SEE TABLE				

CUSTOMER DRAWING

350589