

PRODUCT NUMBER
78515-001
78515-001LF

OBSOLETE

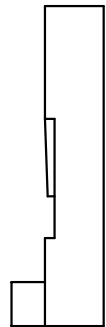
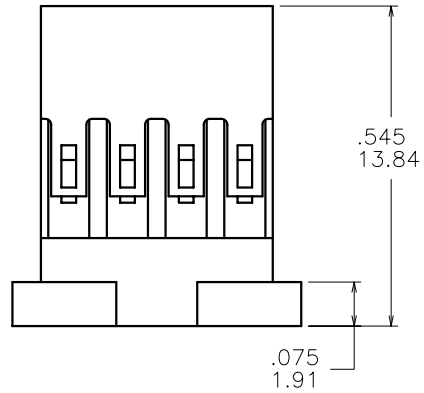

NOTES:

- ① MOLDING MATERIAL: POLYAMIDE (PA66),
FLAME RETARDANT PER UL-94V-0,
COLOR: BLACK.
- 2. TO BE MATED WITH PIN .225/5.72
±.015/0.38 LONG.
- 3. THIS HOUSING IS INTENDED FOR USE
WITH MINI PV™ TERMINAL WITH 22-36 AWG WIRE.
- 4. FOR APPLICATION INFORMATION SEE TA-531.
PRODUCT SPECIFICATION: BUS-12-067.
- 5. PRODUCT MEETS EUROPEAN UNION DIRECTIVES AND
OTHER COUNTRY REGULATIONS AS DESCRIBED
IN GS-22-008.
- 6. THIS PRODUCT IS NOT INTENDED TO BE EXPOSED
TO MANUFACTURING SOLDER PROCESSES.

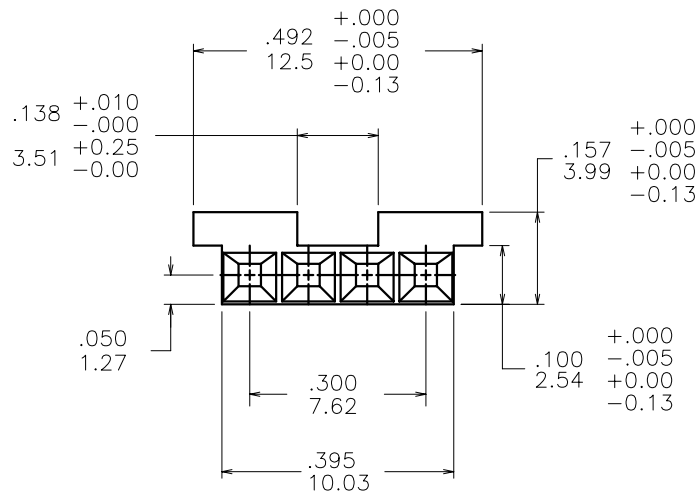

Copyright FCI

mat'l. code SEE NOTE 1		surface	tolerance	projection	product family PV HOUSINGS	
ltr	ec'n no	dr	date	tolerances unless otherwise specified	title	
A	v12499	JWB	1991-09-09	angles	MINI LATCH HOUSING SR POLARIZED .100 [2.54] CC	
B	v50128	GAH	1995-04-10	linear		
C	v05-0717	TAB	2005-07-29	0°±2'		
D	v06-0446	HTB	2006-05-16	dr	J.W. BAIR	1991-09-09
E	v07-0533	HTB	2007-08-22	engr	C. TREXLER	1991-09-09
				chr	C. TREXLER	1991-09-09
				appd	C. TREXLER	1991-09-09
sheet	revision	E				
index	sheet	1				