

1

2

3

4

5

6

7

A

B

C

D

E

F

G

H

Material

Terminal body(metal housing): Brass(CuZn)
 Terminal screw: Steel Zinc plating "-" slot type
 Wire guard: Stainless steel
 Surface of solder tail: Tin plated
 Insulator (housing): Thermoplastic (UL94V-0).BLACK

Electrical cULus

Voltage rating: 300VAC
 Current rating: 15A
 Wire range:
 Solid wire(AWG): 14-22
 Stranded wire(AWG): 14-22
 Torque(Lb-In): 3.5
 Screw: M3
 Wire strip length: 6-7mm
 Withstanding Voltage: 1.6KV
 Operating temperature: -40°C to +115°C
 Soldering temperature: 250°C±10°C/5 Sec
 Safety Approval: 

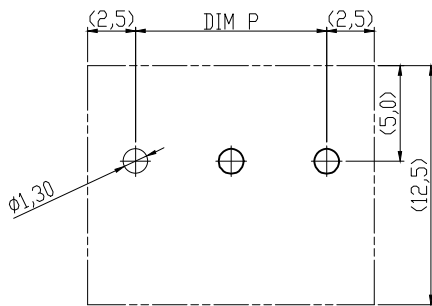
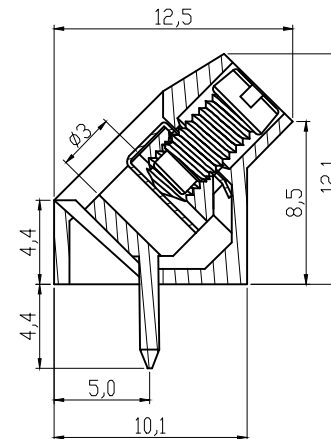
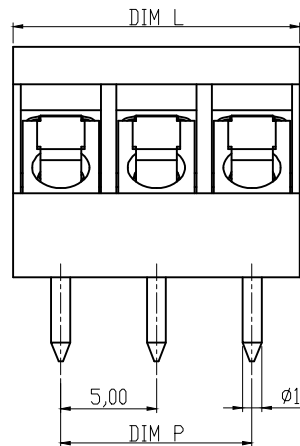
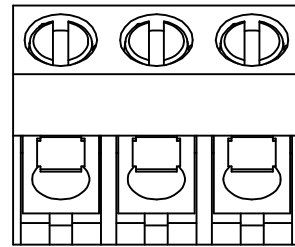

RECOMMENDER PCB LAYOUT

DIMENSION

L	Nx5.0
P	(N-1)x5.0

N=Number of poles

Poles	Tolerance	
	DIM L	DIM P
2p-6p	±0.20	±0.15
7p-12p	±0.25	±0.20
13p-18p	±0.30	±0.25
19p-24p	±0.40	±0.30

Scale	1:1					Date	Name	Customer-No.
TOLERANCE						Drawn	Alex	ASSMANN WSW-No. A-TB500-TQxxSB
X.	±0.50					Approved	Joanna	
X.X	±0.30							Drawing-No.
X.XX	±0.10							ASS 4094 CO
DIM	TOL	①	Add UL	18.04.2016	Joanna			
X.°	±1°	②	Drawn	19.04.2010	Alex			
Angle	TOL	Id.	Modification	Date	Name	Replace	Sheet	

RoHS compliant
 Unit: mm



File No.: E349947

1

2

3

4

5

6

7

A

B

C

D

E

F

G

H