

**THIS PRODUCT MANUFACTURED WITH LEAD-FREE PROCESSING**

**DESIGNED & DIMENSIONED IN MILLIMETERS [INCHES]**

**TNC-P-C-XX-SR-C10**

GENDER -P: PLUG  
 TYPE -C: CABLE  
 TERMINATION -C10: CCA-058 CABLE  
 ORIENTATION -SR: STRAIGHT, REVERSE POLARITY

PLATING SPECIFICATION (VALUES GIVEN ARE IN MICRO-INCHES)  
 -GN: GOLD/NICKEL  
 10 Au / 50 Ni MIN ON CENTER CONTACT  
 100 Ni MIN ON OUTER CONTACT  
 (SEE TABLE 1)

DO NOT SCALE FROM THIS PRINT

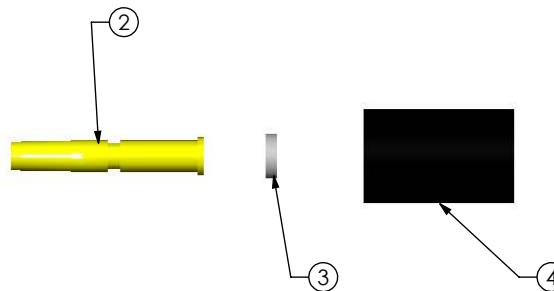
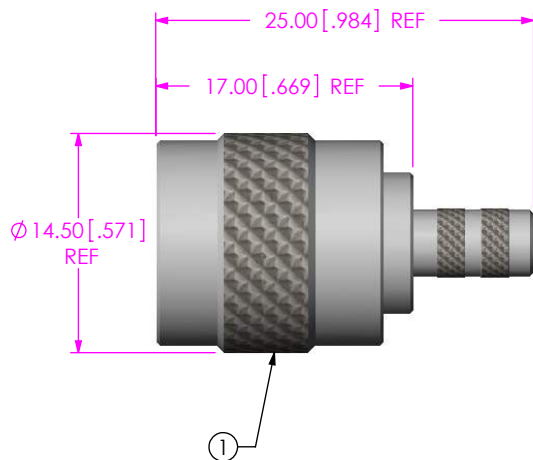

ITEM	COMPONENT	-GN
1	SUB ASSEMBLY	SUB-TNC-P-C-N-SR-C10
2	SOCKET	TNC-SKT-002-G
3	INSULATOR	TNC-INS-002
4	FERRULE	TNC-FER-003-N

NOTES:

- Ⓢ REPRESENTS A CRITICAL DIMENSION.
- CENTER CONTACT PUSHOUT FORCE: 26.69 N [6LB] MIN
- NOTE DELETED
- NOTE DELETED
- PRODUCT TO BE PACKAGED PER PACKAGING STANDARD CO-HD-WI-3040-M
- NOTE DELETED
- NOTE DELETED
- NOTE DELETED

C:\EnterpriseVault\DWG\MISC\MKTG\TNC-P-C-XX-SR-C10-MKT.SLDDRW

<p>UNLESS OTHERWISE SPECIFIED, DIMENSIONS ARE IN MILLIMETERS [INCHES]</p> <p>TOLERANCES ARE:</p> <p>DECIMALS ANGLES</p> <p>.X: ±0.3 [.01] 2°</p> <p>.XX: ±0.13 [.005]</p> <p>.XXX: ±0.051 [.0020]</p>	<p>PROPRIETARY NOTE</p> <p>THIS DOCUMENT CONTAINS INFORMATION CONFIDENTIAL AND PROPRIETARY TO SAMTEC, INC. AND SHALL NOT BE REPRODUCED OR TRANSFERRED TO OTHER DOCUMENTS OR DISCLOSED TO OTHERS OR USED FOR ANY PURPOSE OTHER THAN THAT WHICH IT WAS OBTAINED WITHOUT THE EXPRESSED WRITTEN CONSENT OF SAMTEC, INC.</p>	<p>520 PARK EAST BLVD., NEW ALBANY, IN 47150                  PHONE: 812-944-6733 FAX: 812-948-5047                  e-Mail: info@SAMTEC.com code: 53322</p>



IN-PROCESS 1  
STRIP AND TIN INNER CONDUCTOR

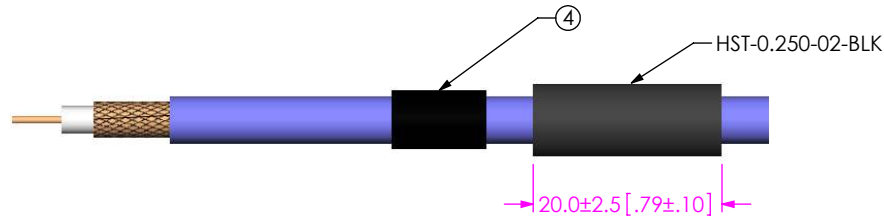

IN-PROCESS 2  
ADD HEAT SHRINK TUBE AND FERRULE

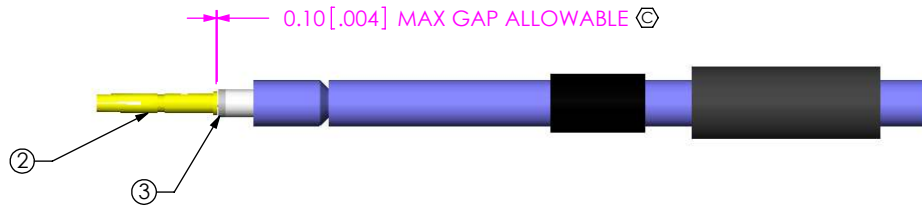

IN-PROCESS 3  
ADD INSULATOR, SOLDER CONTACT

$0.10^{+0.10}_{-0.15} [.004^{+.004}_{-.006}]$   
TO CENTER CONTACT

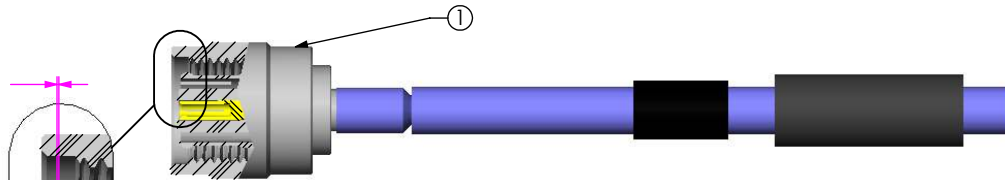

IN-PROCESS 4  
ADD SUB-ASSEMBLY

DETAIL 'A'  
SCALE 2.5 : 1

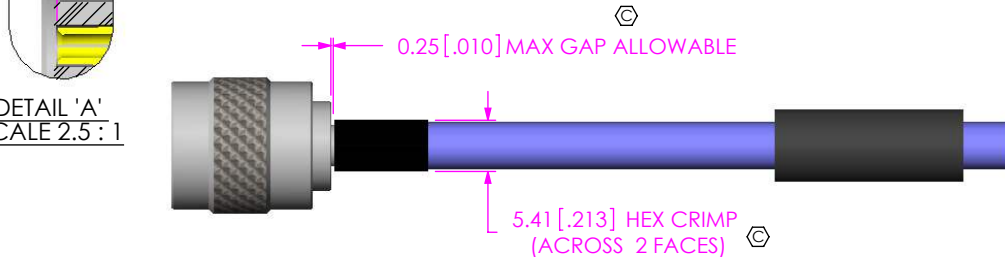

IN-PROCESS 5  
CRIMP FERRULE  
(USE RF CRIMP HAND TOOL #CAT-HT-12667-21 OR EQUIVALENT)  
(USE .213" HEX DIE)

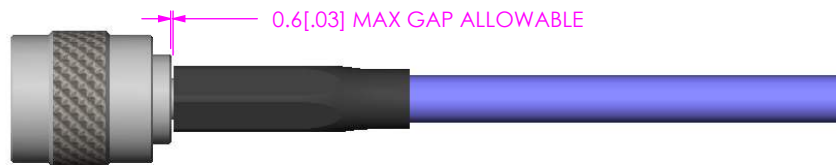

IN-PROCESS 6  
APPLY HEAT SHRINK TUBE

K

C:\EnterpriseVault\DWG\MISC\MKTG\TNC-P-C-XX-SR-C10-MKT.SLDDRW

**PROPRIETARY NOTE**  
THIS DOCUMENT CONTAINS INFORMATION  
CONFIDENTIAL AND PROPRIETARY TO  
SAMTEC, INC. AND SHALL NOT BE REPRODUCED  
OR TRANSFERRED TO OTHER DOCUMENTS OR  
DISCLOSED TO OTHERS OR USED FOR ANY  
PURPOSE OTHER THAN THAT WHICH IT WAS  
OBTAINED WITHOUT THE EXPRESSED WRITTEN  
CONSENT OF SAMTEC, INC.



520 PARK EAST BLVD, NEW ALBANY, IN 47150  
PHONE: 812-944-6733 FAX: 812-948-5047  
e-Mail: info@SAMTEC.com code: 55322

DO NOT SCALE DRAWING

SHEET SCALE: 1.25:1

DESCRIPTION:  
TNC STRAIGHT REVERSE POLARITY CABLE PLUG, RG58 - 50 OHM

DWG. NO.  
TNC-P-C-XX-SR-C10

BY: R MUSSER 12/19/2007 SHEET 2 OF 2