

PART NAME: KNOB SCALE: 1:1 DATE: 10/11/02 DR. BY JAM

THIS DRAWING IS THE PROPERTY OF DAVIES MOLDING COMPANY, IS SUBMITTED SOLELY AS A DESIGN OR ENGINEERING PROJECT. WE ACCEPT NO RESPONSIBILITY WHATSOEVER FOR THE PRACTICAL APPLICATION OF THE PIECES MADE TO THIS DESIGN.



DESIGNERS & MANUFACTURERS OF KNOBS, HANDLES, CASES & CUSTOM PLASTIC COMPONENTS

P/N 1202CY

M NO. 1200-9-1,-2

SPRING I2241

(A)

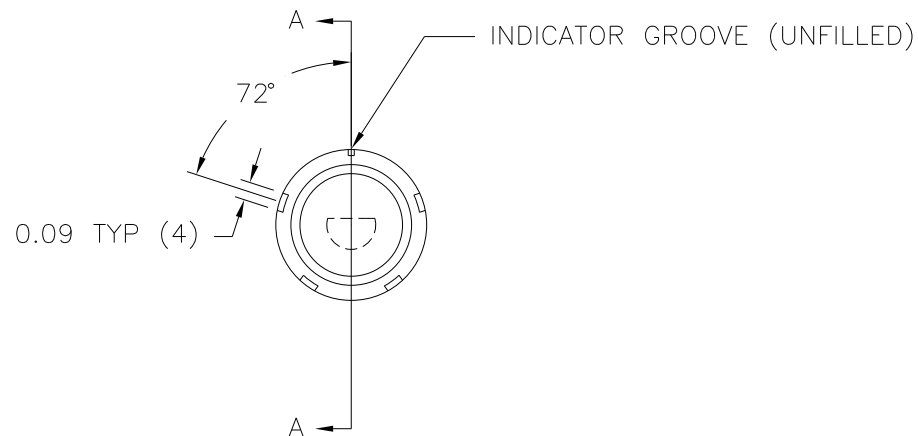

SECTION A-A

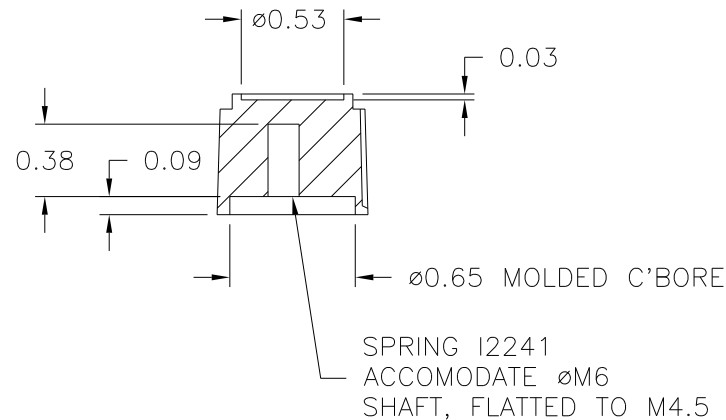
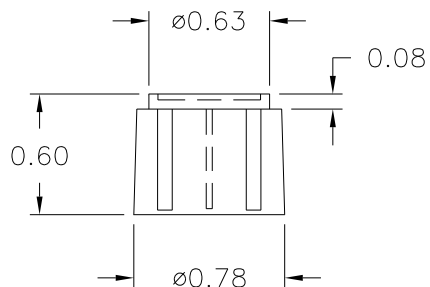

NOTE: ALL MOLDED PARTS MUST BE CHECKED WITH SPECIAL GAUGE.
KEYWAY PIN MUST ACCEPT MOLDED HOLE
MATERIAL: G.P. PHENOLIC (B11)
COLOR: BLACK

TOLERANCES: UNLESS OTHERWISE SPECIFIED	DO NOT SCALE DRAWING				
DECIMALS: X.XXX ± .005 X.XX ± .015	MM: X.XX ± 0.15MM X.X ± 0.4MM	A	ADDED BASE PART	EW	6/27/14
		-	WAS SK1202-04	JAM	10/11/02
FRACTIONS ± 1/64	ANG. ± 1°	CHANGES			

PART NAME: KNOB SCALE: 1:1 DATE: 10/11/02 DR. BY JAM

THIS DRAWING IS THE PROPERTY OF DAVIES MOLDING COMPANY, IS SUBMITTED SOLELY AS A DESIGN OR ENGINEERING PROJECT. WE ACCEPT NO RESPONSIBILITY WHATSOEVER FOR THE PRACTICAL APPLICATION OF THE PIECES MADE TO THIS DESIGN.



DESIGNERS & MANUFACTURERS OF KNOBS, HANDLES, CASES & CUSTOM PLASTIC COMPONENTS

P/N 1202CY

M NO. 1200-9-1,-2

SPRING I2241

(A)

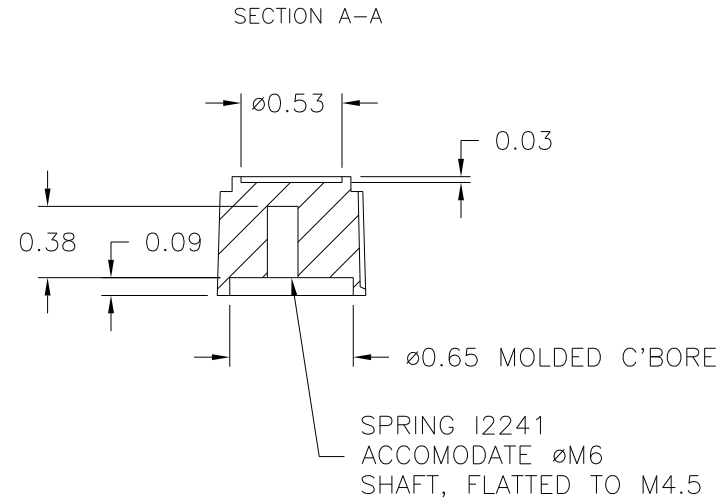
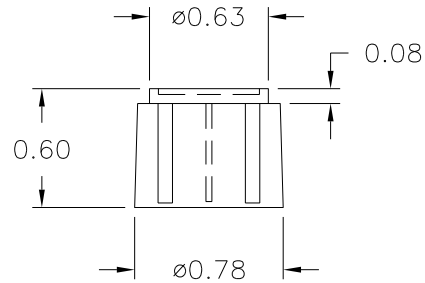
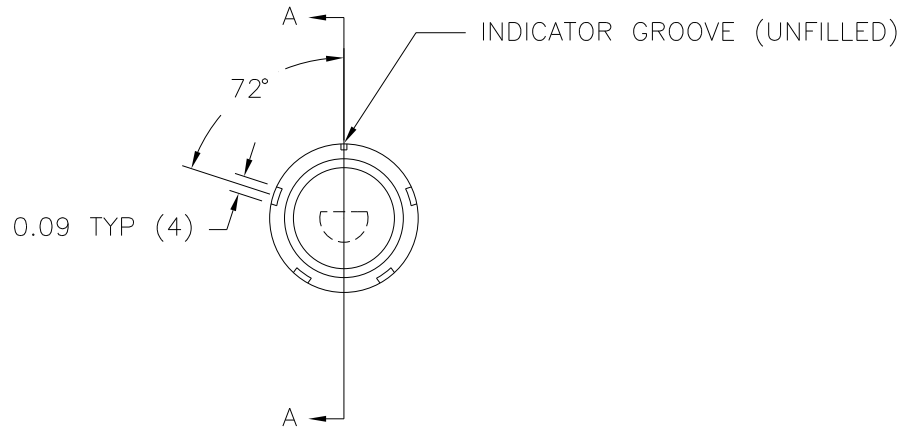

NOTE: ALL MOLDED PARTS MUST BE CHECKED WITH SPECIAL GAUGE.
KEYWAY PIN MUST ACCEPT MOLDED HOLE
MATERIAL: G.P. PHENOLIC (B11)
COLOR: BLACK

TOLERANCES: UNLESS OTHERWISE SPECIFIED	DO NOT SCALE DRAWING				
DECIMALS: X.XXX ± .005 X.XX ± .015	MM: X.XX ± 0.15MM X.X ± 0.4MM	A	ADDED BASE PART	EW	6/27/14
FRACTIONS ± 1/64	ANG. ± 1°	-	WAS SK1202-04	JAM	10/11/02
CHANGES					