

UNIT : mm

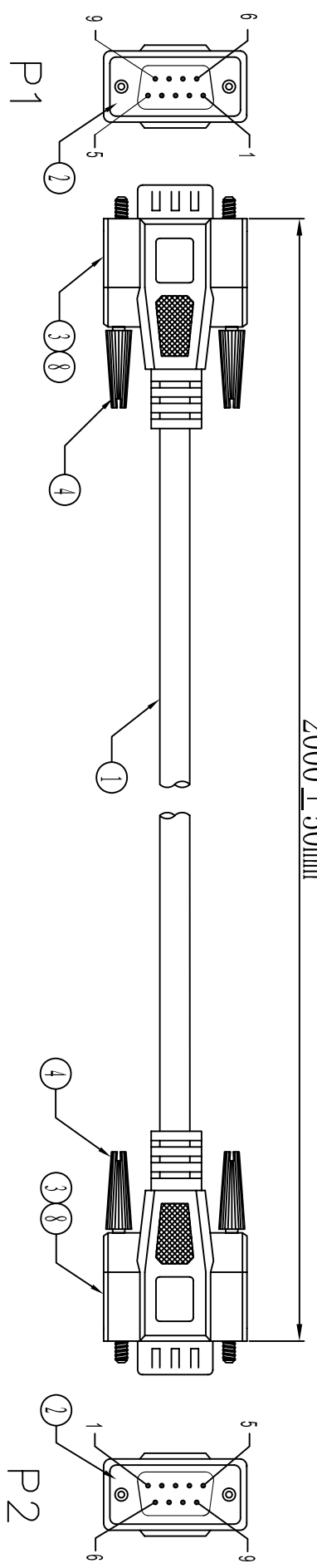

Electronic Test:
 1. 100% Test.(Open,Short, Miss Wire)
 2. Contact Resistance: 2 ohm max.
 3. Insulation Resistance: 5M ohm min.
 4. Hi-Pot: 300V DC/10ms

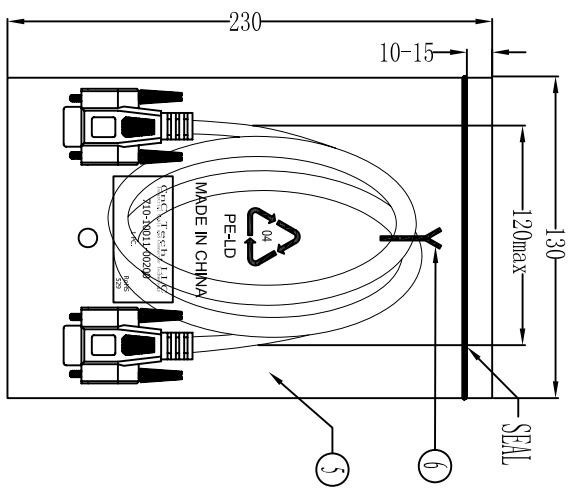

PIN ASSIGNMENT

P1	BLACK	P2	1
1	GREY	1	1
2	YELLOW	2	2
3	PURPLE	3	3
4	ORANGE	4	4
5	RED	5	5
6	BROWN	6	6
7	GREEN	7	7
8	BLUE	8	8
9	D.W	9	9
SHELL		SHELL	

⑧	TUBE	2	HEAT SHRINK TUBE BLACK OD1.5*LT15MM
⑦	PE BAG	1/10	CLEAR SIZE:280*330*0.05mm PRINT BLACK*MADE IN CHINA*+*10PCS* 及印生产周期,有透气孔.
⑥	TIE	1	WHITE L=100mm
⑤	PE BAG	1	CLEAR SIZE:130*230*0.05mm PRINT BLACK*MADE IN CHINA*及印生产周期,有透气孔.
④	SCREW	4	SCREW:#4-40UNC L47mm,NICKEL PLATED,INSULATION COLOR BEIGE(V-29)
③	OUT JACKET	43.5g	BEIGE(V-29) 40P PVC(MOULD NO:WM-113)
②	CONN	8g	CLEAR LDPE(MOULD NO:NM-049)
①	CABLE	1	DB 9PIN MALE PIN G/F SHELL-NICKEL SOLDER TYPE INSULATION COLOR BLUE NOUL 30AWG(7/0.10)*9C+D.W+A/L/M*+JACKET COROL:BEIGE(V-29) OD:5.0mm. L2000±10mm.

CNC Tech, LLC
 Industrial Cable and Connector Technology

DRAWN BY	ZHONGHS	DRAWING NO.	
CHECKED BY		CUSTOMER	
APPROVAL BY		ITEM NO.	710-10011-00200
DECIDE BY		DATE	2012-02-06
VERSIONS/EDITION	A/0	PROJECTION	

4 3 2 1 4 3 2 1