



---

## 4-wire Serial Interface Real Time Clock Module

---

NO.EA-113-230419

### OUTLINE

The R2045S/D is a real-time clock module, built in CMOS real-time clock IC and crystal oscillator, connected to the CPU by four signal lines, CE, SCLK, SI, and SO, and configured to perform serial transmission of time and calendar data to the CPU. The oscillation frequency is adjusted to high precision ( $0\pm 5$ ppm: 13 sec. per month at  $25^{\circ}\text{C}$ ). The periodic interrupt circuit is configured to generate interrupt signals with six selectable interrupts ranging from 0.5 seconds to 1 month. The 2 alarm interrupt circuits generate interrupt signals at preset times. As the oscillation circuit is driven under constant voltage, fluctuation of the oscillator frequency due to supply voltage is small, and the time keeping current is small (TYP.  $0.48\mu\text{A}$  at 3V). The oscillation halt sensing circuit can be used to judge the validity of internal data in such events as power-on. The supply voltage monitoring circuit is configured to record a drop in supply voltage below two selectable supply voltage monitoring threshold settings. The 32-kHz clock output function (N-channel Open drain output) is intended to output sub-clock pulses for the external microcomputer. The oscillation adjustment circuit is intended to adjust time by correcting deviations in the oscillation frequency of the crystal oscillator.

### FEATURES

- Built in 32.768kHz crystal unit, The oscillation frequency is adjusted to high precision ( $0\pm 5$ ppm: at  $25^{\circ}\text{C}$ )
- Time keeping voltage 1.15V to 5.5V
- Super low power consumption  $0.48\mu\text{A}$  TYP ( $1.2\mu\text{A}$  MAX) at  $V_{\text{DD}}=3\text{V}$
- Four signal lines (CE, SCLK, SI, and SO) required for connection to the CPU.
- Time counters (counting hours, minutes, and seconds) and calendar counters (counting years, months, days, and weeks) (in BCD format)
- Interrupt circuit configured to generate interrupt signals (with interrupts ranging from 0.5 seconds to 1 month) to the CPU and provided with an interrupt flag and an interrupt halt
- 2 alarm interrupt circuits (Alarm\_W for week, hour, and minute alarm settings and Alarm\_D for hour and minute alarm settings)
- 32768Hz clock output pin (N-channel open drain output)
- With Power-on flag to prove that the power supply starts from 0V
- With Oscillation halt sensing Flag to judge the validity of internal data
- Supply voltage monitoring circuit with two supply voltage monitoring threshold settings
- Automatic identification of leap years up to the year 2099
- Selectable 12-hour and 24-hour mode settings
- Oscillation adjustment circuit for correcting temperature frequency deviation or offset deviation
- CMOS process
- Two types of package, SOP14(10.1x7.4x3.1) or SON22(6.1x5.0x1.3)

## PIN CONFIGURATION

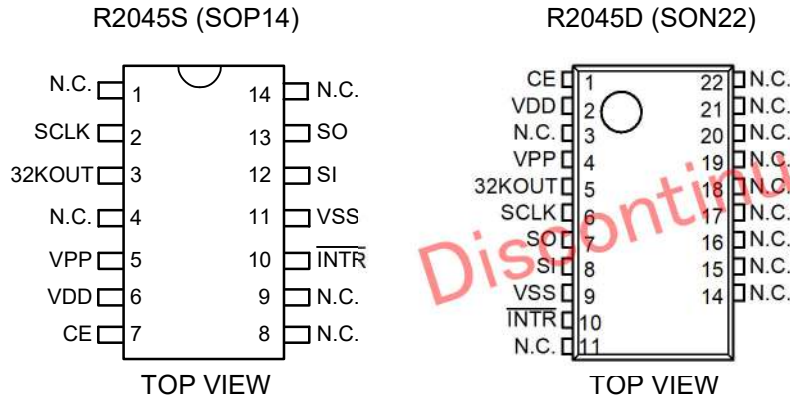

## BLOCK DIAGRAM

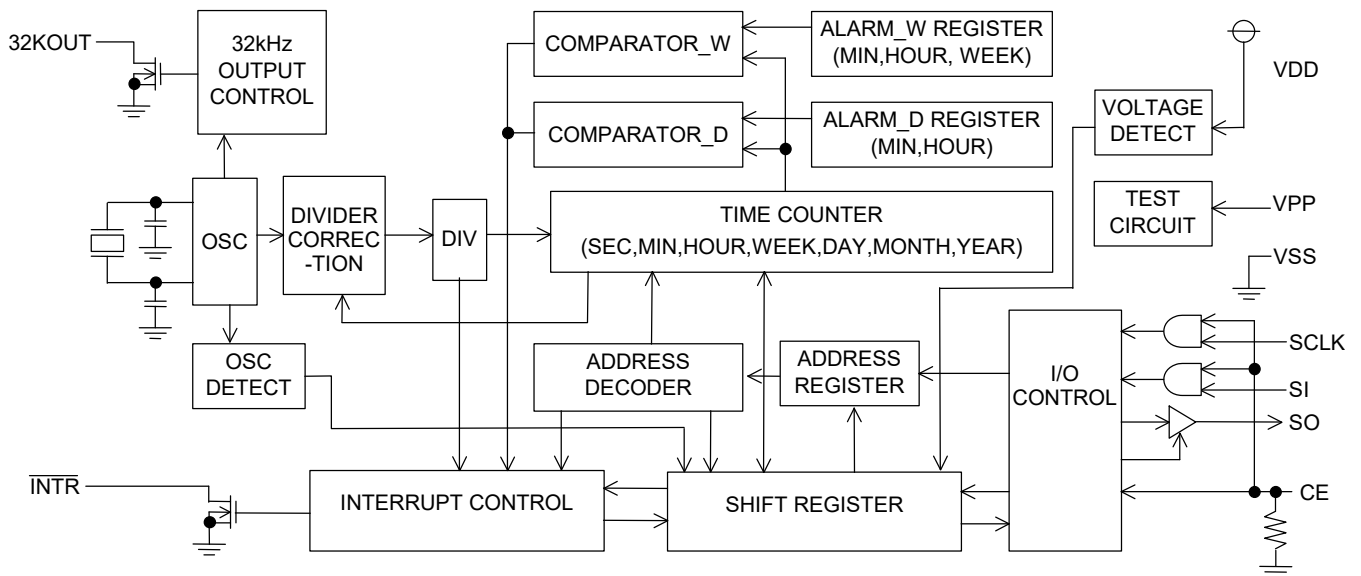

## SELECTION GUIDE

Part Number is designated as follows:

R2045 S- E2 - FE ←Part Number

↑ ↑ ↑

R2045 a - bb - cc

Code	Description
a	Designation of the package. D: SON22 S: SOP14
bb	Designation of the taping type. Only E2 is available.
cc	Designation of the lead plating. F: Lead free plating (SON22) FE: Lead free plating (SOP14)

## PIN DESCRIPTION

Symbol	Item	Description
CE	Chip enable Input	The CE pin is used for interfacing with the CPU. Should be held high to allow access to the CPU. Incorporates a pull-down resistor. Should be held low or open when the CPU is powered off. Allows a maximum input voltage of 5.5v regardless of supply voltage.
SCLK	Serial Clock Input	The SCLK pin is used to input clock pulses synchronizing the input and output of data to and from the SI and SO pins. Allows a maximum input voltage of 5.5v regardless of supply voltage.
SI	Serial Input	The SI pin is used to input data intended for writing in synchronization with the SCLK pin. CMOS input. Allows a maximum input voltage of 5.5v regardless of supply voltage.
SO	Serial Output	The SO pin is used to output data intended for reading in synchronization with the SCLK pin. CMOS output.
$\overline{\text{INTR}}$	Interrupt Output	The $\overline{\text{INTR}}$ pin is used to output alarm interrupt (Alarm_W) and alarm interrupt (Alarm_D) and output periodic interrupt signals to the CPU signals. Disabled at power-on from 0V. N-channel open drain output. Allows a maximum pull-up voltage of 5.5v regardless of supply voltage.
32KOUT	32kHz Clock Output	The 32KOUT pin is used to output 32.768-kHz clock pulses. And controlled by resister setting. When VDD power-on from 0v, this output is enabled. The pin is N-channel open drain output. Allows a maximum pull-up voltage of 5.5v regardless of supply voltage.
VDD	Positive Power Supply Input	The VDD pin is connected to the power supply.
VSS	Negative Power Supply Input	The VSS pin is grounded.
VPP	Test input	This pin is power pin for testing in the factory. Please don't connect to any other pins.
N.C.	No Connection	These pins are not connected to internal IC chip. In R2045D (SON22), N.C. pins from 14 pin to 22 pin are connected together internally. Never connect these pins to any lines, or connect to VDD or VSS. And never connect different voltage level lines each other.

## ABSOLUTE MAXIMUM RATINGS

(V<sub>SS</sub>=0V)

Symbol	Item	Pin Name and Condition	Description	Unit
V <sub>DD</sub>	Supply Voltage	VDD	-0.3 to +6.5	V
V <sub>i</sub>	Input Voltage 1	CE, SCLK, SI	-0.3 to +6.5	V
	Input Voltage 2	VPP	-0.3 to V <sub>DD</sub> +0.3	
V <sub>o</sub>	Output Voltage 1	SO	-0.3 to V <sub>DD</sub> +0.3	V
	Output Voltage 2	$\overline{\text{INTR}}$ , 32KOUT	-0.3 to +6.5	
P <sub>d</sub>	Power Dissipation	T <sub>opt</sub> =25°C	300	mW
T <sub>opt</sub>	Operating Temperature		-40 to +85	°C
T <sub>stg</sub>	Storage Temperature		-55 to +125	°C

Electronic and mechanical stress momentarily exceeded absolute maximum ratings may cause the permanent damage and may degrade the lifetime and safety for both device and system using the device in the field. The functional operation at or over these absolute maximum ratings is not assured.

## RECOMMENDED OPERATING CONDITION

(V<sub>SS</sub>=0V, T<sub>opt</sub>=-40 to +85°C)

Symbol	Item	Pin Name and Condition	Min.	Typ.	Max.	Unit
V <sub>ACCESS</sub>	Supply Voltage	VDD power supply voltage for interfacing with CPU	1.7		5.5	V
V <sub>CLK</sub>	Time Keeping Voltage		1.15		5.5	V
V <sub>PUP</sub>	Pull-up Voltage	$\overline{\text{INTR}}$			5.5	V

All of electronic equipment should be designed that the mounted semiconductor devices operate within the recommended operating conditions. The semiconductor devices cannot operate normally over the recommended operating conditions, even if when they are used over such conditions by momentary electronic noise or surge. And the semiconductor devices may receive serious damage when they continue to operate over the recommended operating conditions.

## FREQUENCY CHARACTERISTICS

(V<sub>SS</sub>=0V)

Symbol	Item	Condition	Min.	Typ.	Max.	Unit
$\Delta f/f_0$	Frequency Deviation	T <sub>opt</sub> =25°C, V <sub>DD</sub> =3V	-5	0	+5	ppm
F <sub>v</sub>	Frequency Voltage Characteristics	T <sub>opt</sub> =25°C, V <sub>DD</sub> =2.0V to 5.5V	-1		+1	ppm
Top	Frequency Temperature Characteristics	T <sub>opt</sub> =-20°C to +70°C 25°C as standard	-120		+10	ppm
t <sub>sta</sub>	Oscillation Start-up Time	T <sub>opt</sub> =25°C, V <sub>DD</sub> =2V			+1	sec
f <sub>a</sub>	Aging	T <sub>opt</sub> =25°C, V <sub>DD</sub> =3V, First year	-5		+5	ppm

## DC ELECTRICAL CHARACTERISTICS

Unless otherwise specified:  $V_{SS}=0V, V_{DD}=3V, T_{opt}=-40$  to  $+85^{\circ}C$

Symbol	Item	Pin Name	Condition	Min.	Typ.	Max.	Unit
$V_{IH}$	"H" Input Voltage	CE, SCLK, SI	$V_{DD}=1.7$ to $5.5V$	$0.8 \times V_{DD}$		5.5	V
$V_{IL}$	"L" Input Voltage			-0.3		$0.2 \times V_{DD}$	
$I_{OH}$	"H" Output Current	SO	$V_{OH}=V_{DD}-0.5V$			-0.5	mA
$I_{OL1}$	"L" Output Current	$\overline{INTR}$	$V_{OL}=0.4V$	2.0			mA
$I_{OL2}$		SO, 32KOUT		0.5			
$I_{IL}$	Input Leakage Current	SCLK, SI	$V_I=5.5V$ or $V_{SS}$ $V_{DD}=5.5V$	-1.0		1.0	$\mu A$
$R_{DNCE}$	Pull-down Resistance	CE		40	120	400	k $\Omega$
$I_{OZ1}$	Output Off-state Leakage Current	SO	$V_O=5.5V$ or $V_{SS}$ $V_{DD}=5.5V$	-1.0		1.0	$\mu A$
$I_{OZ2}$		$\overline{INTR}$ , 32KOUT	$V_O=5.5V$	-1.0		1.0	
$I_{DD1}$	Time Keeping Current	VDD	$V_{DD}=3V$ , CE, SCLK, SI, SO, $\overline{INTR}$ , 32KOUT $=V_{SS}$ 32KOUT disabled		0.48	1.20	$\mu A$
$I_{DD2}$		VDD	$V_{DD}=5V$ , CE, SCLK, SI, SO, $\overline{INTR}$ , 32KOUT $=V_{SS}$ 32KOUT disabled		0.60	1.80	
$I_{DD3}$		VDD	$V_{DD}=3V$ , CE, SCLK, SI, SO, $\overline{INTR}$ , 32KOUT $=V_{SS}$ 32KOUT enabled		0.65	2.00	
$V_{DETH}$	Supply Voltage Monitoring Voltage ("H")	VDD	$T_{opt}=-30$ to $+70^{\circ}C$	1.90	2.10	2.30	V
$V_{DETL}$	Supply Voltage Monitoring Voltage ("L")	VDD	$T_{opt}=-30$ to $+70^{\circ}C$	1.15	1.30	1.45	V

## AC ELECTRICAL CHARACTERISTICS

Unless otherwise specified:  $V_{SS}=0V$ ,  $T_{opt}=-40$  to  $+85^{\circ}C$

Input / Output condition:  $V_{IH}=0.8xV_{DD}$ ,  $V_{IL}=0.2xV_{DD}$ ,  $V_{OH}=0.8xV_{DD}$ ,  $V_{OL}=0.2xV_{DD}$ ,  $C_L=50pF$

Symbol	Item	Condi- tions	$V_{DD} \geq 1.7V$			Unit
			Min.	Typ.	Max.	
$t_{CES}$	CE Set-up Time		400			ns
$t_{CEH}$	CE Hold Time		400			ns
$t_{CR}$	CE Recovery Time		62			$\mu s$
$f_{SCLK}$	SCLK Clock Frequency				1.0	MHz
$t_{CKH}$	SCLK Clock High Time		400			ns
$t_{CKL}$	SCLK Clock Low Time		400			ns
$t_{CKS}$	SCLK Set-up Time		200			ns
$t_{RD}$	Data Output Delay Time				300	ns
$t_{RZ}$	Data Output Floating Time				300	ns
$t_{CEZ}$	Data Output Delay Time After Falling of CE				300	ns
$t_{DS}$	Input Data Set-up Time		200			ns
$t_{DH}$	Input Data Hold Time		200			ns

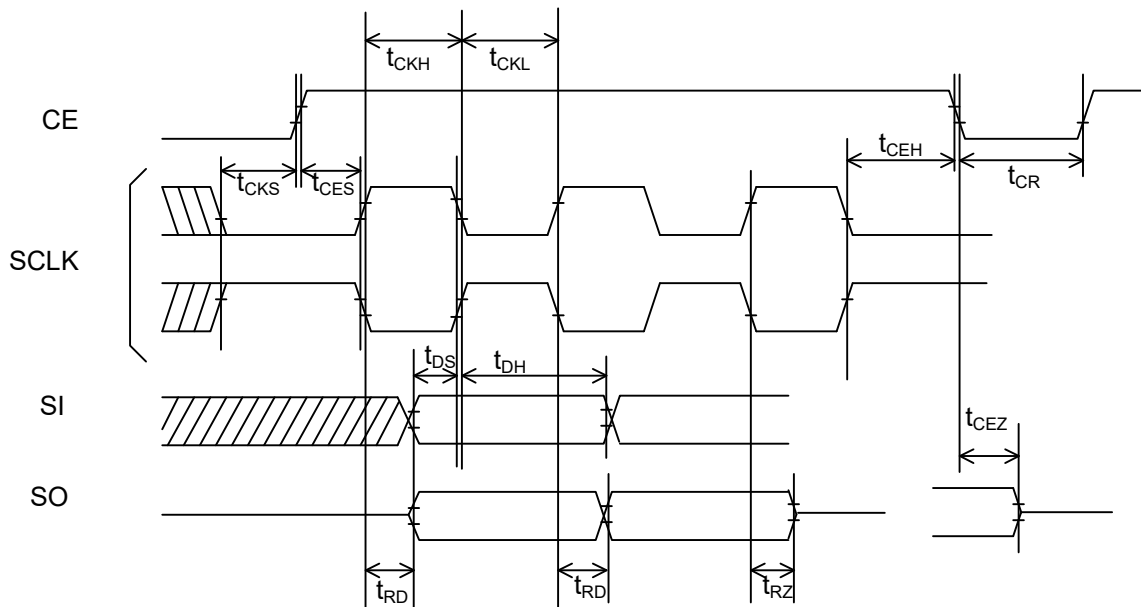

\*) For reading/writing timing, see "Considerations in Reading and Writing Time Data under special condition".

## PACKAGE DIMENSIONS

### • R2045S (SOP14)

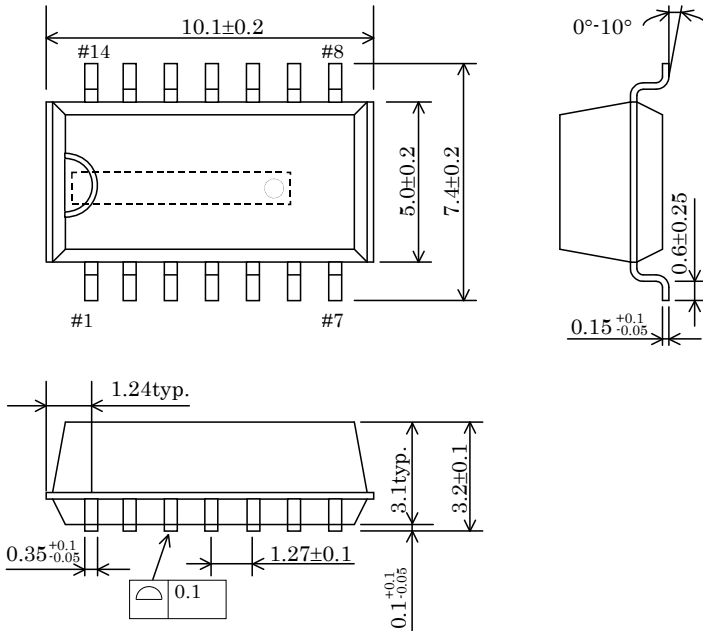

### • R2045D (SON22)

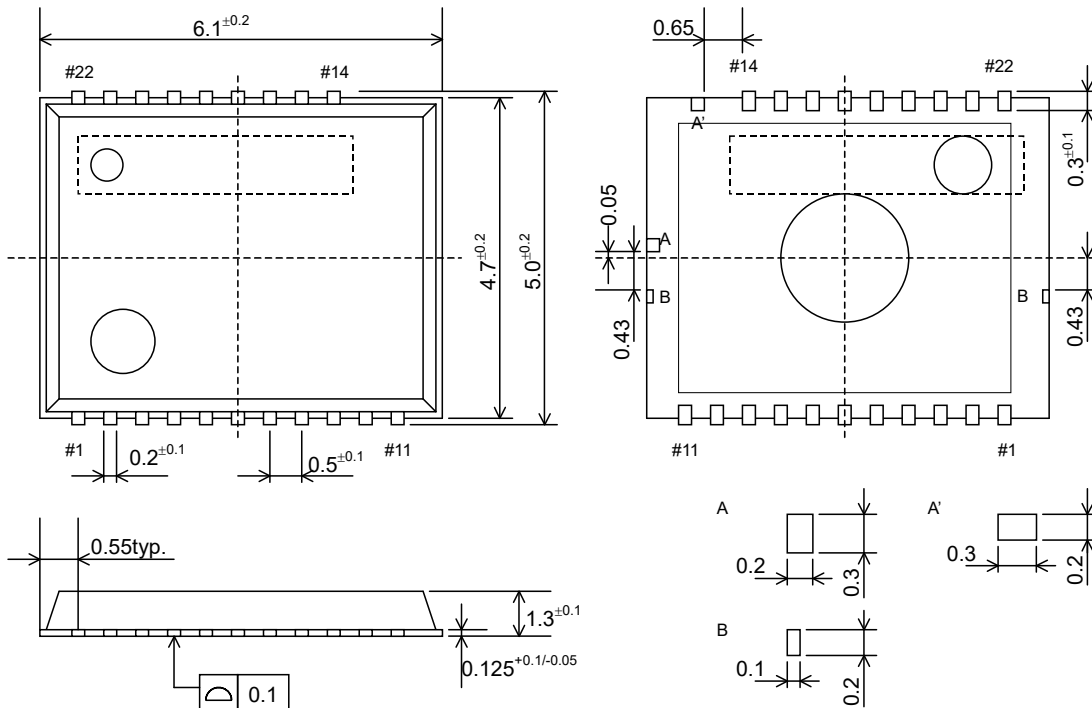

## MARK SPECIFICATION

- **R2045S (SOP14)**

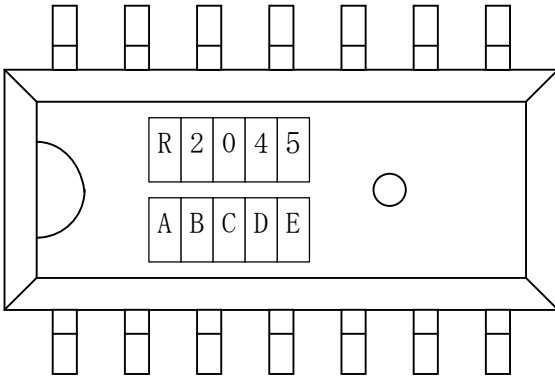

ABCDE : Lot Number

- **R2045D (SON22)**

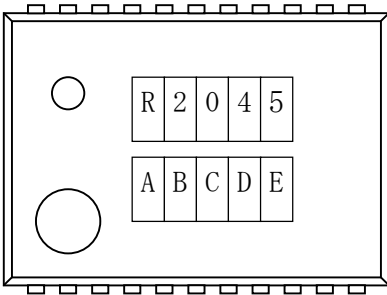

ABCDE : Lot Number



## GENERAL DESCRIPTION

### • Interface with CPU

The R2045S/D is connected to the CPU by four signal lines CE (Chip Enable), SCLK (Serial Clock), SI (Serial Input), and SO (Serial Output), through which it reads and writes data from and to the CPU. The CPU can be accessed when the CE pin is held high. Access clock pulses have a maximum frequency of 1 MHz allowing high-speed data transfer to the CPU.

### • Clock and Calendar Function

The R2045S/D reads and writes time data from and to the CPU in units ranging from seconds to the last two digits of the calendar year. The calendar year will automatically be identified as a leap year when its last two digits are a multiple of 4. Consequently, leap years up to the year 2099 can automatically be identified as such.

### • Alarm Function

The R2045S/D incorporates the alarm interrupt circuit configured to generate interrupt signals to the CPU at preset times. The alarm interrupt circuit allows two types of alarm settings specified by the Alarm\_W registers and the Alarm\_D registers. The Alarm\_W registers allow week, hour, and minute alarm settings including combinations of multiple day-of-week settings such as "Monday, Wednesday, and Friday" and "Saturday and Sunday". The Alarm\_D registers allow hour and minute alarm settings. The Alarm\_W outputs from  $\overline{\text{INTR}}$  pin, and the Alarm\_D outputs also from  $\overline{\text{INTR}}$  pin. Each alarm function can be checked from the CPU by using a polling function.

### High-precision Oscillation Adjustment Function

To correct deviations in the oscillation frequency of the crystal oscillator, the oscillation adjustment circuit is configured to allow correction of a time count gain or loss (up to  $\pm 1.5$  ppm at 25°C) from the CPU within a maximum range of approximately + 189 ppm in increments of approximately 3 ppm. Such oscillation frequency adjustment in each system has the following advantages:

- \* Corrects seasonal frequency deviations through seasonal oscillation adjustment.
- \* Allows timekeeping with higher precision particularly with a temperature sensing function out of RTC, through oscillation adjustment in tune with temperature fluctuations.

### • Oscillation Halt Sensing Flag, Power-on Reset Flag, and Supply Voltage Monitoring Function

The R2045S/D incorporates an oscillation halt sensing circuit equipped with internal registers configured to record any past oscillation halt.

Power-on reset flag is set to "1" When R2045S/D is powered on from 0V.

As such, the oscillation halt sensing flag and Power-on reset flag are useful for judging the validity of time data.

The R2045S/D also incorporates a supply voltage monitoring circuit equipped with internal registers configured to record any drop in supply voltage below a certain threshold value. Supply voltage monitoring threshold settings can be selected between 2.1 and 1.3 volts through internal register settings. The oscillation halt sensing circuit is configured to confirm the established invalidation of time data in contrast to the supply voltage monitoring circuit intended to confirm the potential invalidation of time data. Further, the supply voltage monitoring circuit can be applied to battery supply voltage monitoring.

- **Periodic Interrupt Function**

The R2045S/D incorporates the periodic interrupt circuit configured to generate periodic interrupt signals aside from interrupt signals generated by the periodic interrupt circuit for output from the  $\overline{\text{INTR}}$  pin. Periodic interrupt signals have five selectable frequency settings of 2 Hz (once per 0.5 seconds), 1 Hz (once per 1 second), 1/60 Hz (once per 1 minute), 1/3600 Hz (once per 1 hour), and monthly (the first day of every month). Further, periodic interrupt signals also have two selectable waveforms, a normal pulse form (with a frequency of 2 Hz or 1 Hz) and special form adapted to interruption from the CPU in the level mode (with second, minute, hour, and month interrupts). The condition of periodic interrupt signals can be monitored by using a polling function.

- **32kHz Clock Output**

The R2045S/D incorporates a 32-kHz clock circuit configured to generate clock pulses with the oscillation frequency of a 32.768kHz crystal oscillator for output from the 32KOUT pin. The 32-kHz clock output can be disabled by certain register settings but cannot be disabled without manipulation of any two registers with different addresses to prevent disabling in such events as the runaway of the CPU.

## Address Mapping

	Address				Register Name	Data							
	A3	A2	A1	A0		D7	D6	D5	D4	D3	D2	D1	D0
0	0	0	0	0	Second Counter	- *2)	S40	S20	S10	S8	S4	S2	S1
1	0	0	0	1	Minute Counter	-	M40	M20	M10	M8	M4	M2	M1
2	0	0	1	0	Hour Counter	-	-	H20 P/ $\bar{A}$	H10	H8	H4	H2	H1
3	0	0	1	1	Day-of-week Counter	-	-	-	-	-	W4	W2	W1
4	0	1	0	0	Day-of-month Counter	-	-	D20	D10	D8	D4	D2	D1
5	0	1	0	1	Month Counter and Century Bit	19 /20	-	-	MO10	MO8	MO4	MO2	MO1
6	0	1	1	0	Year Counter	Y80	Y40	Y20	Y10	Y8	Y4	Y2	Y1
7	0	1	1	1	Oscillation Adjustment Register *3)	(0) *4)	F6	F5	F4	F3	F2	F1	F0
8	1	0	0	0	Alarm_W (Minute Register)	-	WM40	WM20	WM10	WM8	WM4	WM2	WM1
9	1	0	0	1	Alarm_W (Hour Register)	-	-	WH20 WP/ $\bar{A}$	WH10	WH8	WH4	WH2	WH1
A	1	0	1	0	Alarm_W (Day-of-week Register)	-	WW6	WW5	WW4	WW3	WW2	WW1	WW0
B	1	0	1	1	Alarm_D (Minute Register)	-	DM40	DM20	DM10	DM8	DM4	DM2	DM1
C	1	1	0	0	Alarm_D (Hour Register)	-	-	DH20 DP/ $\bar{A}$	DH10	DH8	DH4	DH2	DH1
D	1	1	0	1		-	-	-	-	-	-	-	-
E	1	1	1	0	Control Register 1 *3)	WALE	DALE	12 /24	CLEN2	TEST	CT2	CT1	CT0
F	1	1	1	1	Control Register 2 *3)	VDSL	VDET	XST	PON *5)	CLEN1	CTFG	WAFG	DAFG

## Notes:

\*1) All the data listed above accept both reading and writing.

\*2) The data marked with "-" is invalid for writing and reset to 0 for reading.

\*3) When the PON bit is set to 1 in Control Register 2, all the bits are reset to 0 in Oscillation Adjustment Register, Control Register 1 and Control Register 2 excluding the  $\bar{XST}$  and PON bits.

\*4) The (0) bit should be set to 0.

\*5)  $\bar{XST}$  is oscillation halt sensing bit.

\*6) PON is power-on reset flag.

## Register Settings

### • Control Register 1 (ADDRESS Eh)

D7	D6	D5	D4	D3	D2	D1	D0	
WALE	DALE	$\overline{12}/24$	$\overline{CLEN2}$	TEST	CT2	CT1	CT0	(For Writing)
WALE	DALE	$\overline{12}/24$	$\overline{CLEN2}$	TEST	CT2	CT1	CT0	(For Reading)
0	0	0	0	0	0	0	0	Default Settings *)

\*) Default settings: Default value means read / written values when the PON bit is set to "1" due to VDD power-on from 0 volts.

#### (1) WALE, DALE Alarm\_W Enable Bit, Alarm\_D Enable Bit

WALE,DALE	Description	
0	Disabling the alarm interrupt circuit (under the control of the settings of the Alarm_W registers and the Alarm_D registers).	(Default)
1	Enabling the alarm interrupt circuit (under the control of the settings of the Alarm_W registers and the Alarm_D registers)	

#### (2) $\overline{12}/24$ $\overline{12}/24$ -hour Mode Selection Bit

$\overline{12}/24$	Description	
0	Selecting the 12-hour mode with a.m. and p.m. indications.	(Default)
1	Selecting the 24-hour mode	

Setting the  $\overline{12}/24$  bit to 0 and 1 specifies the 12-hour mode and the 24-hour mode, respectively.

24-hour mode	12-hour mode	24-hour mode	12-hour mode
00	12 (AM12)	12	32 (PM12)
01	01 (AM 1)	13	21 (PM 1)
02	02 (AM 2)	14	22 (PM 2)
03	03 (AM 3)	15	23 (PM 3)
04	04 (AM 4)	16	24 (PM 4)
05	05 (AM 5)	17	25 (PM 5)
06	06 (AM 6)	18	26 (PM 6)
07	07 (AM 7)	19	27 (PM 7)
08	08 (AM 8)	20	28 (PM 8)
09	09 (AM 9)	21	29 (PM 9)
10	10 (AM10)	22	30 (PM10)
11	11 (AM11)	23	31 (PM11)

Setting the  $\overline{12}/24$  bit should precede writing time data

#### (3) $\overline{CLEN2}$ 32-kHz Clock Output Bit2

$\overline{CLEN2}$	Description	
0	Enabling the 32-kHz clock output	(Default)
1	Disabling the 32-kHz clock output	

Setting the  $\overline{CLEN2}$  bits or the  $\overline{CLEN1}$  bit (D3 in the control register 2) to 0 specifies generating clock pulses with the oscillation frequency of the 32.768-kHz crystal oscillator for output from the 32KOUT pin. Conversely, setting both the  $\overline{CLEN1}$  and the  $\overline{CLEN2}$  bit to 1 specifies disabling ("H") such output.

**(4) TEST**

**Test Bit**

TEST	Description
0	Normal operation mode.
1	Test mode.

(Default)

The TEST bit is used only for testing in the factory and should normally be set to 0.

**(5) CT2,CT1, and CT0 Periodic Interrupt Selection Bits**

CT2	CT1	CT0	Description	
			Wave form mode	Interrupt Cycle and Falling Timing
0	0	0	-	OFF(H)
0	0	1	-	Fixed at "L"
0	1	0	Pulse Mode *1)	2Hz(Duty50%)
0	1	1	Pulse Mode *1)	1Hz(Duty50%)
1	0	0	Level Mode *2)	Once per 1 second (Synchronized with second counter increment)
1	0	1	Level Mode *2)	Once per 1 minute (at 00 seconds of every minute)
1	1	0	Level Mode *2)	Once per hour (at 00 minutes and 00 seconds of every hour)
1	1	1	Level Mode *2)	Once per month (at 00 hours, 00 minutes, and 00 seconds of first day of every month)

(Default)

\* 1) Pulse Mode: 2-Hz and 1-Hz clock pulses are output in synchronization with the increment of the second counter as illustrated in the timing chart below.

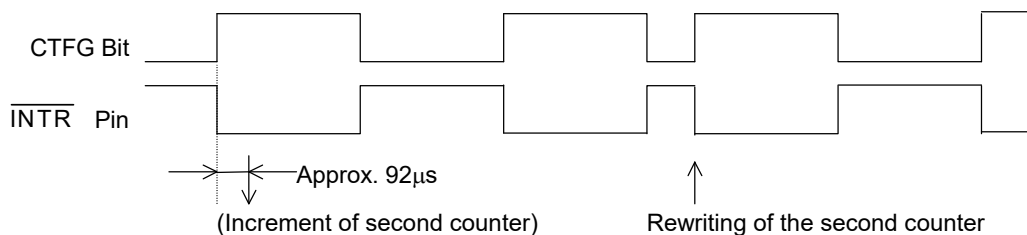

In the pulse mode, the increment of the second counter is delayed by approximately 92 μs from the falling edge of clock pulses. Consequently, time readings immediately after the falling edge of clock pulses may appear to lag behind the time counts of the real-time clocks by approximately 1 second. Rewriting the second counter will reset the other time counters of less than 1 second, driving the  $\overline{\text{INTR}}$  pin low.

\* 2) Level Mode: Periodic interrupt signals are output with selectable interrupt cycle settings of 1 second, 1 minute, 1 hour, and 1 month. The increment of the second counter is synchronized with the falling edge of periodic interrupt signals. For example, periodic interrupt signals with an interrupt cycle setting of 1 second are output in synchronization with the increment of the second counter as illustrated in the timing chart below.

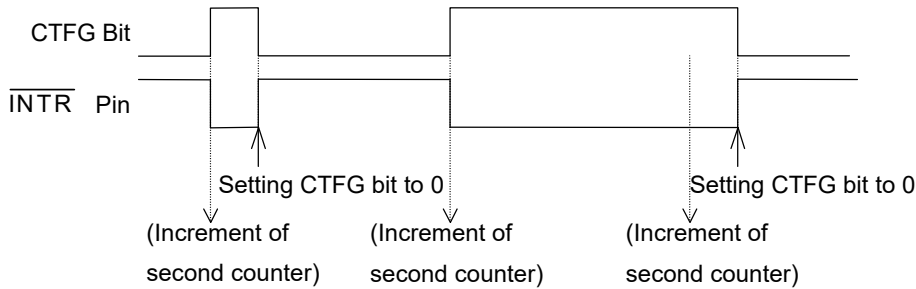

\*1), \*2) When the oscillation adjustment circuit is used, the interrupt cycle will fluctuate once per 60sec. as follows:

Pulse Mode:

The "L" period of output pulses will increment or decrement by a maximum of  $\pm 3.784$  ms. For example, 1-Hz clock pulses will have a duty cycle of  $50 \pm 0.3784\%$ .

Level Mode:

A periodic interrupt cycle of 1 second will increment or decrement by a maximum of  $\pm 3.784$  ms.

• **Control Register 2 (Address Fh)**

D7	D6	D5	D4	D3	D2	D1	D0	
VDSL	VDET	$\overline{XST}$	PON	$\overline{CLEN1}$	CTFG	WAF G	DAFG	(For Writing)
VDSL	VDET	$\overline{XST}$	PON	$\overline{CLEN1}$	CTFG	WAF G	DAFG	(For Reading)
0	0	Indefinite	1	0	0	0	0	Default Settings *)

\*) Default settings: Default value means read / written values when the PON bit is set to "1" due to VDD power-on from 0 volts.

(1) **VDSL VDD Supply Voltage Monitoring Threshold Selection Bit**

VDSL	Description	
0	Selecting the VDD supply voltage monitoring threshold setting of 2.1v.	(Default)
1	Selecting the VDD supply voltage monitoring threshold setting of 1.3v.	

The VDSL bit is intended to select the VDD supply voltage monitoring threshold settings.

(2) **VDET Supply Voltage Monitoring Result Indication Bit**

VDET	Description	
0	Indicating supply voltage above the supply voltage monitoring threshold settings.	(Default)
1	Indicating supply voltage below the supply voltage monitoring threshold settings.	

Once the VDET bit is set to 1, the supply voltage monitoring circuit will be disabled while the VDET bit will hold the setting of 1. The VDET bit accepts only the writing of 0, which restarts the supply voltage monitoring circuit. Conversely, setting the VDET bit to 1 causes no event.

**(3)  $\overline{XST}$  Oscillation Halt Sensing Monitor Bit**

$\overline{XST}$	Description
0	Sensing a halt of oscillation
1	Sensing a normal condition of oscillation

The  $\overline{XST}$  accepts the reading and writing of 0 and 1. The  $\overline{XST}$  bit will be set to 0 when the oscillation halt sensing. The  $\overline{XST}$  bit will hold 0 even after the restart of oscillation.

**(4) PON Power-on-reset Flag Bit**

PON	Description
0	Normal condition
1	Detecting VDD power-on -reset

(Default)

The PON bit is for sensing power-on reset condition.

\* The PON bit will be set to 1 when VDD power-on from 0 volts. The PON bit will hold the setting of 1 even after power-on.

\* When the PON bit is set to 1, all bits will be reset to 0, in the Oscillation Adjustment Register, Control Register 1, and Control Register 2, except  $\overline{XST}$  and PON. As a result,  $\overline{INTR}$  pin stops outputting, and 32KOUT starts outputting.

\* The PON bit accepts only the writing of 0. Conversely, setting the PON bit to 1 causes no event.

**(5)  $\overline{CLEN1}$  32-kHz Clock Output Bit 1**

$\overline{CLEN1}$	Description
0	Enabling the 32-kHz clock output
1	Disabling the 32-kHz clock output

(Default)

Setting the  $\overline{CLEN1}$  bit or the  $\overline{CLEN2}$  bit (D4 in the control register 1) to 0 specifies generating clock pulses with the oscillation frequency of the 32.768-kHz crystal oscillator for output from the 32KOUT pin.

Conversely, setting both the  $\overline{CLEN1}$  and the  $\overline{CLEN2}$  bit to 1 specifies disabling ("H") such output.

**(6) CTFG Periodic Interrupt Flag Bit**

CTFG	Description
0	Periodic interrupt output = "H"
1	Periodic interrupt output = "L"

(Default)

The CTFG bit is set to 1 when the periodic interrupt signals are output from the  $\overline{INTR}$  pin ("L"). The CTFG bit accepts only the writing of 0 in the level mode, which disables ("H") the  $\overline{INTR}$  pin until it is enabled ("L") again in the next interrupt cycle. Conversely, setting the CTFG bit to 1 causes no event.

**(7) WAFG,DAFG Alarm\_W Flag Bit and Alarm\_D Flag Bit**

WAFG,DAFG	Description
0	Indicating a mismatch between current time and preset alarm time
1	Indicating a match between current time and preset alarm time

(Default)

The WAFG and DAFG bits are valid only when the WALE and DALE have the setting of 1, which is caused approximately 61 $\mu$ s after any match between current time and preset alarm time specified by the Alarm\_W registers and the Alarm\_D registers. The WAFG (DAFG) bit accepts only the writing of 0.  $\overline{INTR}$  pin outputs off ("H") when this bit is set to 0. And  $\overline{INTR}$  pin outputs "L" again at the next preset alarm time. Conversely, setting the WAFG and DAFG bits to 1 causes no event. The WAFG and DAFG bits will have the reading of 0 when the alarm interrupt circuit is disabled with the WALE and DALE bits set to 0.

The settings of the WAFG (DAFG) bit is synchronized with the output of the  $\overline{INTR}$  pin as shown in the timing chart below.

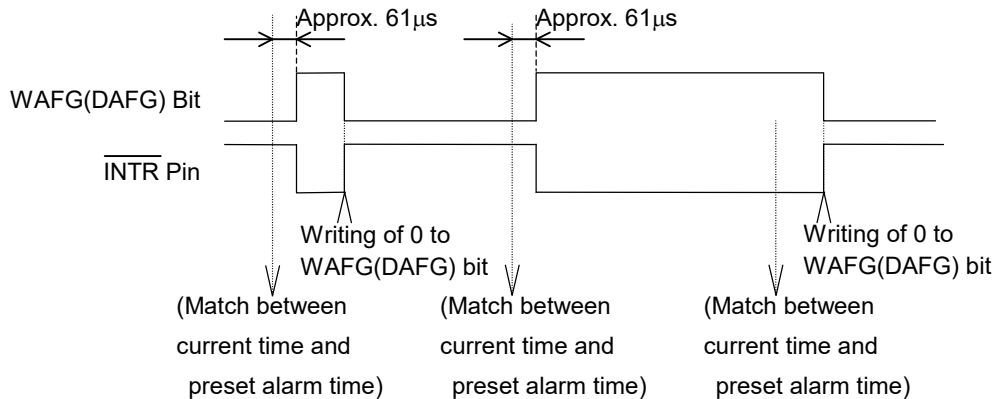

• Time Counter (Address 0-2h)

Second Counter (Address 0h)

D7	D6	D5	D4	D3	D2	D1	D0	
-	S40	S20	S10	S8	S4	S2	S1	(For Writing)
0	S40	S20	S10	S8	S4	S2	S1	(For Reading)
0	Indefinite	Indefinite	Indefinite	Indefinite	Indefinite	Indefinite	Indefinite	Default Settings *)

Minute Counter (Address 1h)

D7	D6	D5	D4	D3	D2	D1	D0	
-	M40	M20	M10	M8	M4	M2	M1	(For Writing)
0	M40	M20	M10	M8	M4	M2	M1	(For Reading)
0	Indefinite	Indefinite	Indefinite	Indefinite	Indefinite	Indefinite	Indefinite	Default Settings *)

Hour Counter (Address 2h)

D7	D6	D5	D4	D3	D2	D1	D0	
-	-	P/ $\bar{A}$ or H20	H10	H8	H4	H2	H1	(For Writing)
0	0	P/ $\bar{A}$ or H20	H10	H8	H4	H2	H1	(For Reading)
0	0	Indefinite	Indefinite	Indefinite	Indefinite	Indefinite	Indefinite	Default Settings *)

\*) Default settings: Default value means read / written values when the PON bit is set to "1" due to VDD power-on from 0 volts.

\* Time digit display (BCD format) as follows:

The second digits range from 00 to 59 and are carried to the minute digit in transition from 59 to 00.

The minute digits range from 00 to 59 and are carried to the hour digits in transition from 59 to 00.

The hour digits range as shown in "P12 •Control Register 1 (ADDRESS Eh) (2)  $\bar{12}/24$ :  $\bar{12}$  -24-hour Mode Selection Bit" and are carried to the day-of-month and day-of-week digits in transition from PM11 to AM12 or from 23 to 00.

\* Any writing to the second counter resets divider units of less than 1 second.

\* Any carry from lower digits with the writing of non-existent time may cause the time counters to malfunction. Therefore, such incorrect writing should be replaced with the writing of existent time data.



• **Day-of-week Counter (Address 3h)**

D7	D6	D5	D4	D3	D2	D1	D0	
-	-	-	-	-	W4	W2	W1	(For Writing)
0	0	0	0	0	W4	W2	W1	(For Reading)
0	0	0	0	0	Indefinite	Indefinite	Indefinite	Default Settings *)

\*) Default settings: Default value means read / written values when the PON bit is set to "1" due to VDD power-on from 0 volts.

\* The day-of-week counter is incremented by 1 when the day-of-week digits are carried to the day-of-month digits.

\* Day-of-week display (incremented in septimal notation):  
(W4, W2, W1) = (0, 0, 0) → (0, 0, 1) → ... → (1, 1, 0) → (0, 0, 0)

\* Correspondences between days of the week and the day-of-week digits are user-definable (e.g. Sunday = 0, 0, 0)

\* The writing of (1, 1, 1) to (W4, W2, W1) is prohibited except when days of the week are unused.

• **Calendar Counter (Address 4-6h)**

**Day-of-month Counter (Address 4h)**

D7	D6	D5	D4	D3	D2	D1	D0	
-	-	D20	D10	D8	D4	D2	D1	(For Writing)
0	0	D20	D10	D8	D4	D2	D1	(For Reading)
0	0	Indefinite	Indefinite	Indefinite	Indefinite	Indefinite	Indefinite	Default Settings *)

**Month Counter + Century Bit (Address 5h)**

D7	D6	D5	D4	D3	D2	D1	D0	
19 /20	-	-	MO10	MO8	MO4	MO2	MO1	(For Writing)
19 /20	0	0	MO10	MO8	MO4	MO2	MO1	(For Reading)
Indefinite	0	0	Indefinite	Indefinite	Indefinite	Indefinite	Indefinite	Default Settings *)

**Year Counter (Address 6h)**

D7	D6	D5	D4	D3	D2	D1	D0	
Y80	Y40	Y20	Y10	Y8	Y4	Y2	Y1	(For Writing)
Y80	Y40	Y20	Y10	Y8	Y4	Y2	Y1	(For Reading)
Indefinite	Indefinite	Indefinite	Indefinite	Indefinite	Indefinite	Indefinite	Indefinite	Default Settings *)

\*) Default settings: Default value means read / written values when the PON bit is set to "1" due to VDD power-on from 0 volts.

\* The calendar counters are configured to display the calendar digits in BCD format by using the automatic calendar function as follows:

The day-of-month digits (D20 to D1) range from 1 to 31 for January, March, May, July, August, October, and December; from 1 to 30 for April, June, September, and November; from 1 to 29 for February in leap years; from 1 to 28 for February in ordinary years. The day-of-month digits are carried to the month digits in reversion from the last day of the month to 1. The month digits (MO10 to MO1) range from 1 to 12 and are carried to the year digits in reversion from 12 to 1.

The year digits (Y80 to Y1) range from 00 to 99 (00, 04, 08, ..., 92, and 96 in leap years) and are carried to the 19 /20 digits in reversion from 99 to 00.

The 19 /20 digits cycle between 0 and 1 in reversion from 99 to 00 in the year digits.

\* Any carry from lower digits with the writing of non-existent calendar data may cause the calendar counters to malfunction. Therefore, such incorrect writing should be replaced with the writing of existent calendar data.

### ● Oscillation Adjustment Register (Address 7h)

D7	D6	D5	D4	D3	D2	D1	D0	
(0)	F6	F5	F4	F3	F2	F1	F0	(For Writing)
0	F6	F5	F4	F3	F2	F1	F0	(For Reading)
0	0	0	0	0	0	0	0	Default Settings *)

\*) Default settings: Default value means read / written values when the PON bit is set to "1" due to VDD power-on from 0 volts.

(0) bit:

(0) bit should be set to 0

F6 to F0 bits:

\* The Oscillation Adjustment Circuit is configured to change time counts of 1 second on the basis of the settings of the Oscillation Adjustment Register when the second digits read 00, 20, or 40 seconds. Normally, the Second Counter is incremented once per 32768 32.768-kHz clock pulses generated by the crystal oscillator. Writing to the F6 to F0 bits activates the oscillation adjustment circuit.

\* The Oscillation Adjustment Circuit will not operate with the same timing (00, 20, or 40 seconds) as the timing of writing to the Oscillation Adjustment Register.

\* The F6 bit setting of 0 causes an increment of time counts by  $((F5, F4, F3, F2, F1, F0) - 1) \times 2$ .

The F6 bit setting of 1 causes a decrement of time counts by  $((\overline{F5}, \overline{F4}, \overline{F3}, \overline{F2}, \overline{F1}, \overline{F0}) + 1) \times 2$ .

The settings of "\*", 0, 0, 0, 0, 0, "\*" ("\*" representing either "0" or "1") in the F6, F5, F4, F3, F2, F1, and F0 bits cause neither an increment nor decrement of time counts.

Example:

When the second digits read 00, 20, or 40, the settings of "0, 0, 0, 0, 1, 1, 1" in the F6, F5, F4, F3, F2, F1, and F0 bits cause an increment of the current time counts of 32768 by  $(7 - 1) \times 2$  to 32780 (a current time count loss). When the second digits read 00, 20, or 40, the settings of "0, 0, 0, 0, 0, 0, 1" in the F6, F5, F4, F3, F2, F1, and F0 bits cause neither an increment nor a decrement of the current time counts of 32768.

When the second digits read 00, 20, or 40, the settings of "1, 1, 1, 1, 1, 1, 0" in the F6, F5, F4, F3, F2, F1, and F0 bits cause a decrement of the current time counts of 32768 by  $(-2) \times 2$  to 32764 (a current time count gain).

An increase of two clock pulses once per 20 seconds causes a time count loss of approximately 3 ppm ( $2 / (32768 \times 20) = 3.051$  ppm). Conversely, a decrease of two clock pulses once per 20 seconds causes a time count gain of 3 ppm. Consequently, deviations in time counts can be corrected with a precision of  $\pm 1.5$  ppm. Note that the oscillation adjustment circuit is configured to correct deviations in time counts and not the oscillation frequency of the 32.768-kHz clock pulses. For further details, see "**Correction of Time Count Deviations**".

• Alarm\_W Registers (Address 8-Ah)

Alarm\_W Minute Register (Address 8h)

D7	D6	D5	D4	D3	D2	D1	D0	
-	WM40	WM20	WM10	WM8	WM4	WM2	WM1	(For Writing)
0	WM40	WM20	WM10	WM8	WM4	WM2	WM1	(For Reading)
0	Indefinite	Indefinite	Indefinite	Indefinite	Indefinite	Indefinite	Indefinite	Default Settings *)

Alarm\_W Hour Register (Address 9h)

D7	D6	D5	D4	D3	D2	D1	D0	
-	-	WH20	WH10	WH8	WH4	WH2	WH1	(For Writing)
0	0	WP/ $\bar{A}$	WH10	WH8	WH4	WH2	WH1	(For Reading)
0	0	Indefinite	Indefinite	Indefinite	Indefinite	Indefinite	Indefinite	Default Settings *)

Alarm\_W Day-of-week Register (Address Ah)

D7	D6	D5	D4	D3	D2	D1	D0	
-	WW6	WW5	WW4	WW3	WW2	WW1	WW0	(For Writing)
0	WW6	WW5	WW4	WW3	WW2	WW1	WW0	(For Reading)
0	Indefinite	Indefinite	Indefinite	Indefinite	Indefinite	Indefinite	Indefinite	Default Settings *)

\*) Default settings: Default value means read / written values when the PON bit is set to "1" due to VDD power-on from 0 volts.

\* The D5 bit of the Alarm\_W Hour Register represents WP/  $\bar{A}$  when the 12-hour mode is selected (0 for a.m. and 1 for p.m.) and WH20 when the 24-hour mode is selected (tens in the hour digits).

\* The Alarm\_W Registers should not have any non-existent alarm time settings.

(Note that any mismatch between current time and preset alarm time specified by the Alarm\_W registers may disable the alarm interrupt circuit.)

\* When the 12-hour mode is selected, the hour digits read 12 and 32 for 0 a.m. and 0 p.m., respectively. (See "Register Settings Control Register 1 (ADDRESS Eh) (2)  $\bar{12}$  /24: 12-/24-hour Mode Selection Bit")

\* WW0 to WW6 correspond to W4, W2, and W1 of the day-of-week counter with settings ranging from (0, 0, 0) to (1, 1, 0).

\* WW0 to WW6 with respective settings of 0 disable the outputs of the Alarm\_W Registers.

Example of Alarm Time Setting

Alarm Preset alarm time	Day-of-week							12-hour mode				24-hour mode			
	Sun.	Mon.	Tue.	Wed.	Th.	Fri.	Sat.	10 hr.	1 hr.	10 min	1 min	10 hr.	1 hr.	10 min	1 min.
	ww	ww	ww	ww	ww	ww	ww								
	0	1	2	3	4	5	6								
00:00 a.m. on all days	1	1	1	1	1	1	1	1	2	0	0	0	0	0	0
01:30 a.m. on all days	1	1	1	1	1	1	1	0	1	3	0	0	1	3	0
11:59 a.m. on all days	1	1	1	1	1	1	1	1	1	5	9	1	1	5	9
00:00 p.m. on Mon. to Fri.	0	1	1	1	1	1	0	3	2	0	0	1	2	0	0
01:30 p.m. on Sun.	1	0	0	0	0	0	0	2	1	3	0	1	3	3	0
11:59 p.m. on Mon., Wed., and Fri.	0	1	0	1	0	1	0	3	1	5	9	2	3	5	9

Note that the correspondence between WW0 to WW6 and the days of the week shown in the above table is only an example and not mandatory.

● Alarm\_D Register (Address B-Ch)

Alarm\_D Minute Register (Address Bh)

D7	D6	D5	D4	D3	D2	D1	D0	
-	DM40	DM20	DM10	DM8	DM4	DM2	DM1	(For Writing)
0	DM40	DM20	DM10	DM8	DM4	DM2	DM1	(For Reading)
0	Indefinite	Indefinite	Indefinite	Indefinite	Indefinite	Indefinite	Indefinite	Default Settings *)

Alarm\_D Hour Register (Address Ch)

D7	D6	D5	D4	D3	D2	D1	D0	
-	-	DH20 DP/ $\bar{A}$	DH10	DH8	DH4	DH2	DH1	(For Writing)
0	0	DH20 DP/ $\bar{A}$	DH10	DH8	DH4	DH2	DH1	(For Reading)
0	0	Indefinite	Indefinite	Indefinite	Indefinite	Indefinite	Indefinite	Default Settings *)

\*) Default settings: Default value means read / written values when the PON bit is set to "1" due to VDD power-on from 0 volts.

\* The D5 bit represents DP/ $\bar{A}$  when the 12-hour mode is selected (0 for a.m. and 1 for p.m.) and DH20 when the 24-hour mode is selected (tens in the hour digits).

\* The Alarm\_D registers should not have any non-existent alarm time settings.

(Note that any mismatch between current time and preset alarm time specified by the Alarm\_D registers may disable the alarm interrupt circuit.)

\* When the 12-hour mode is selected, the hour digits read 12 and 32 for 0a.m. and 0p.m., respectively.

(See "Register Settings • Control Register 1 (ADDRESS Eh) (2)  $\bar{12}$  /24: 12/24-hour Mode Selection Bit")

## Interfacing with the CPU

### • DATA TRANSFER FORMATS

#### (1) Timing between CE Pin Transition and Data Input / Output

The R2045S/D adopts a 4-wire serial interface by which they use the CE (Chip Enable), SCLK (Serial Clock), SI (Serial Input), and SO (Serial Output) pins to receive and send data to and from the CPU. The 4-wire serial interface provides two types of input/output timings with which the SO pin output and the SI pin input are synchronized with the rising or falling edges of the SCLK pin input, respectively, and vice versa. The R2045S/D is configured to select either one of two different input/output timings depending on the level of the SCLK pin in the low to high transition of the CE pin. Namely, when the SCLK pin is held low in the low to high transition of the CE pin, the models will select the timing with which the SO pin output is synchronized with the rising edge of the SCLK pin input, and the SI pin input is synchronized with the falling edge of the SCLK pin input, as illustrated in the timing chart below.

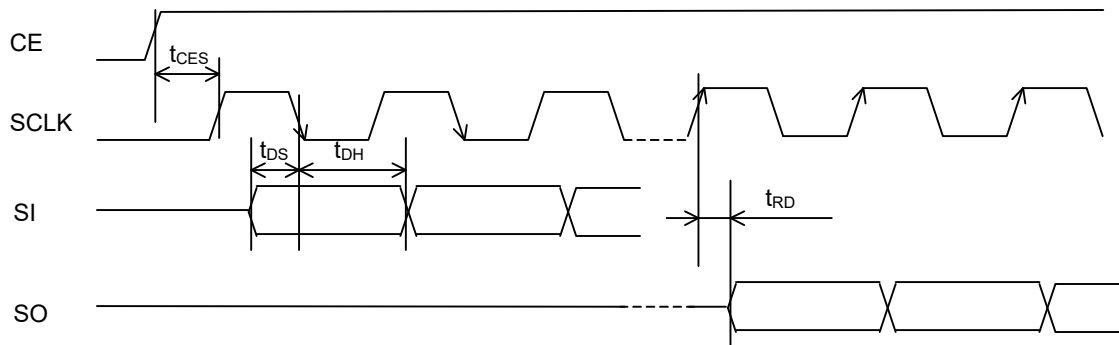

Conversely, when the SCLK pin is held high in the low to high transition of the CE pin, the models will select the timing with which the SO pin output is synchronized with the falling edge of the SCLK pin input, and the SI pin input is synchronized with the rising edge of the SCLK pin input, as illustrated in the timing chart below.

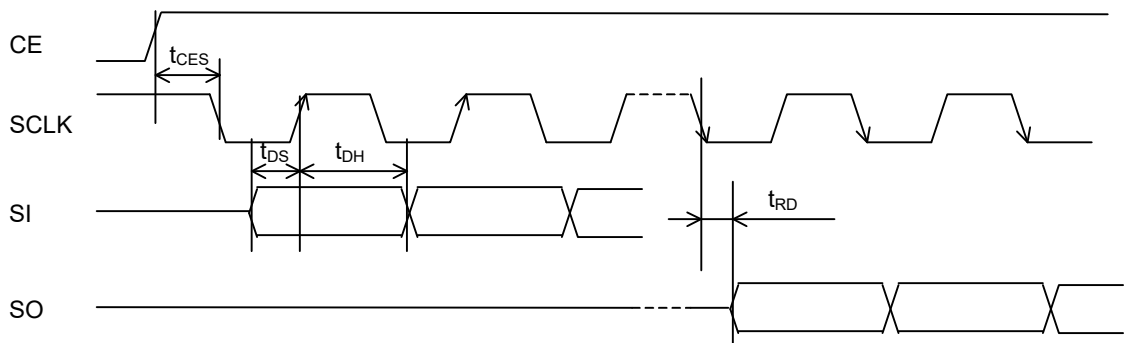

#### (2) Data Transfer Formats

Data transfer is commenced in the low to high transition of the CE pin input and completed in its high to low transition. Data transfer is conducted serially in multiple units of 1 byte (8 bits). The former 4 bits are used to specify in the Address Pointer a head address with which data transfer is to be commenced from the host. The latter 4 bits are used to select either reading data transfer or writing data transfer, and to set the Transfer Format Register to specify an appropriate data transfer format. All data transfer formats are designed to transfer the most significant bit (MSB) first.

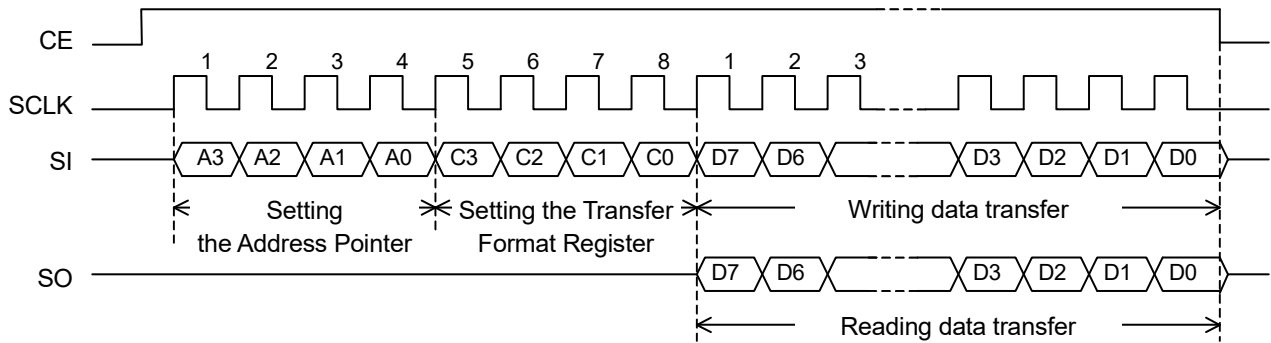

Two types of data transfer formats are available for reading data transfer and writing data transfer each.

• **Writing Data Transfer Formats**

**(1) 1-byte Writing Data Transfer Format**

The first type of writing data transfer format is designed to transfer 1-byte data at a time and can be selected by specifying in the address pointer a head address with which writing data transfer is to be commenced and then writing the setting of 8h to the transfer format register. This 1-byte writing data transfer can be completed by driving the CE pin low or continued by specifying a new head address in the address pointer and setting the data transfer format.

Example of 1-byte Writing Data Transfer (For Writing Data to Addresses Fh and 7h)

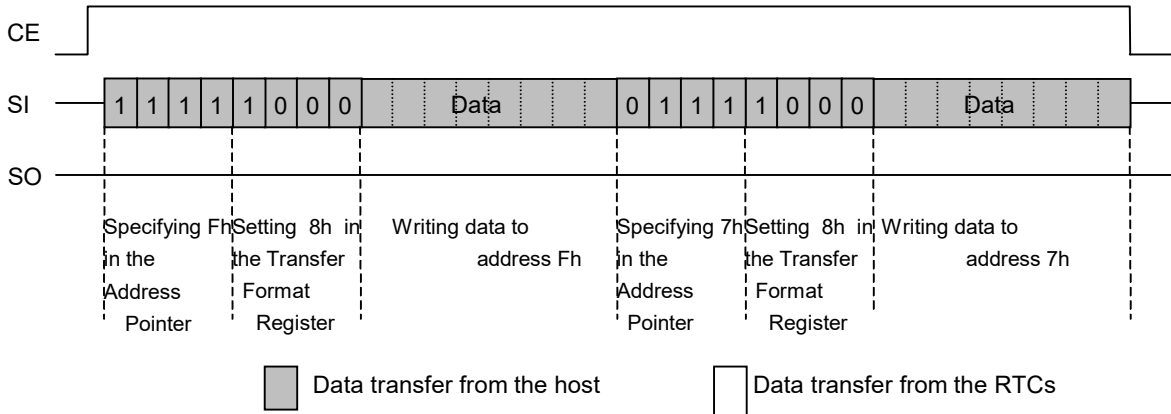

## (2) Burst Writing Data Transfer Format

The second type of writing data transfer format is designed to transfer a sequence of data serially and can be selected by specifying in the address pointer a head address with which writing data transfer is to be commenced and then writing the setting of 0h to the transfer format register. The address pointer is incremented for each transfer of 1-byte data and cycled from Fh to 0h. This burst writing data transfer can be completed by driving the CE pin low.

Example of Burst Writing Data Transfer (For Writing Data to Addresses Eh, Fh, and 0h)

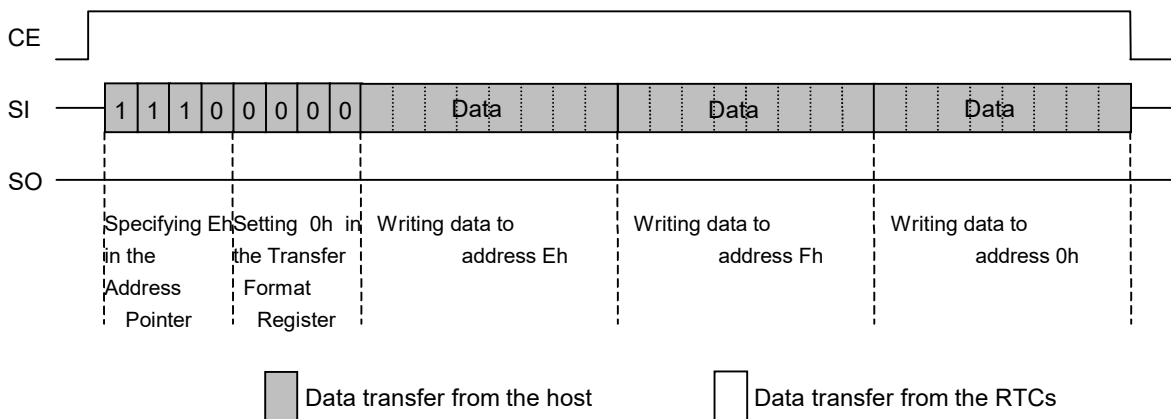

## • Reading Data Transfer Formats

### (1) 1-byte Reading Data Transfer Format

The first type of reading data transfer format is designed to transfer 1-byte data at a time and can be selected by specifying in the Address Pointer a head address with which reading data transfer is to be commenced and then the setting of writing Ch to the Transfer Format Register. This 1-byte reading data transfer can be completed by driving the CE pin low or continued by specifying a new head address in the Address Pointer and selecting this type of reading data Transfer Format.

Example of 1-byte Reading Data Transfer (For Reading Data from Addresses Eh and 2h)

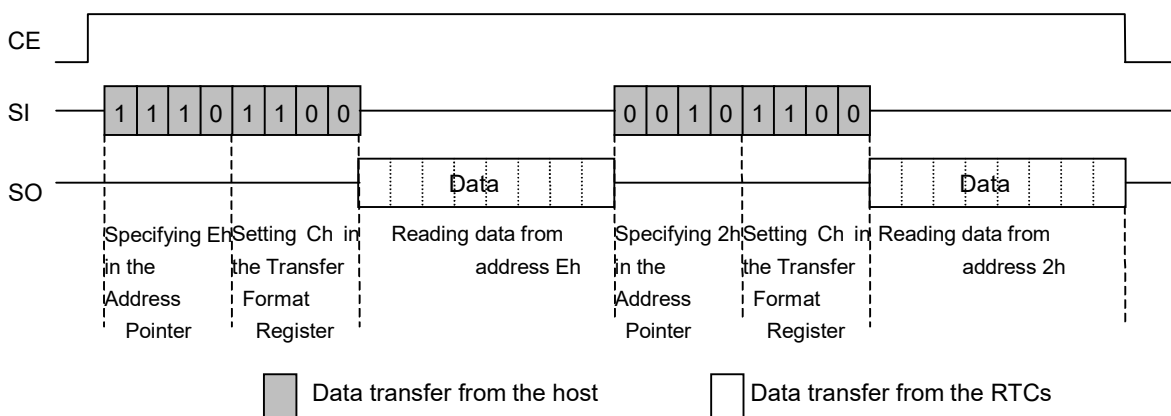

**(2) Burst Reading Data Transfer Format**

The second type of reading data transfer format is designed to transfer a sequence of data serially and can be selected by specifying in the address pointer a head address with which reading data transfer is to be commenced and then writing the setting of 4h to the transfer format register. The address pointer is incremented for each transfer of 1-byte data and cycled from Fh to 0h. This burst reading data transfer can be completed by driving the CE pin low.

Example of Burst Reading Data Transfer (For Reading Data from Addresses Fh, 0h, and 1h)

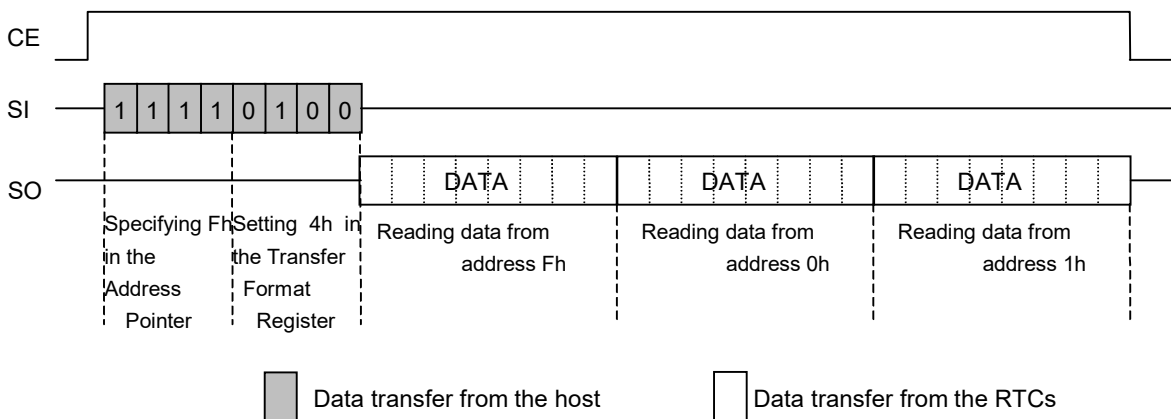

**(3) Combination of 1-byte Reading and writing Data Transfer Formats**

The 1-byte reading and writing data transfer formats can be combined together and further followed by any other data transfer format.

Example of Reading Modify Writing Data Transfer

(For Reading and Writing Data from and to Address Fh)

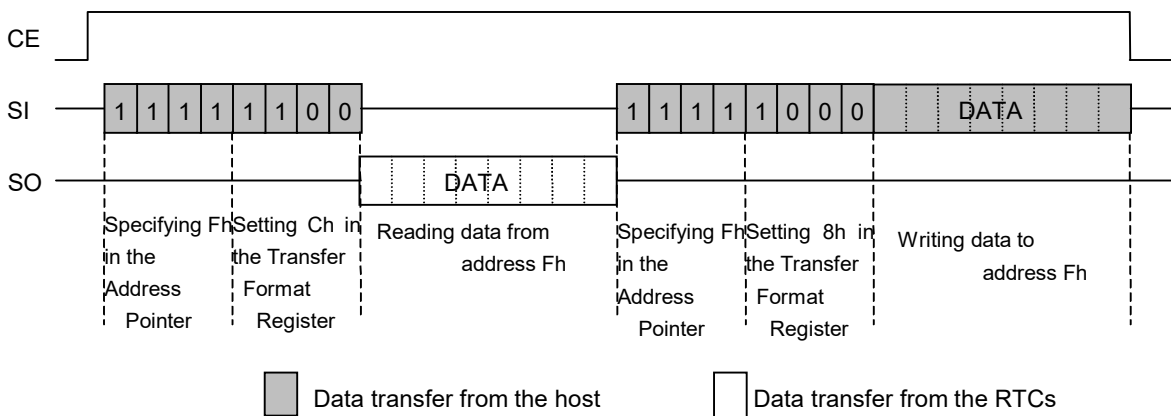

The reading and writing data transfer formats correspond to the settings in the transfer format register as shown in the table below.

	1 Byte	Burst
Writing data transfer	8h (1,0,0,0)	0h (0,0,0,0)
Reading data transfer	Ch (1,1,0,0)	4h (0,1,0,0)



### • Considerations in Reading and Writing Time Data under special condition

Any carry to the second digits in the process of reading or writing time data may cause reading or writing erroneous time data. For example, suppose a carry out of 13:59:59 into 14:00:00 occurs in the process of reading time data in the middle of shifting from the minute digits to the hour digits. At this moment, the second digits, the minute digits, and the hour digits read 59 seconds, 59 minutes, and 14 hours, respectively (indicating 14:59:59) to cause the reading of time data deviating from actual time virtually 1 hour. A similar error also occurs in writing time data. To prevent such errors in reading and writing time data, the R2045S/D has the function of temporarily locking any carry to the second digits during the high interval of the CE pin and unlocking such a carry in its high to low transition. Note that a carry to the second digits can be locked for only 1 second, during which time the CE pin should be driven low.

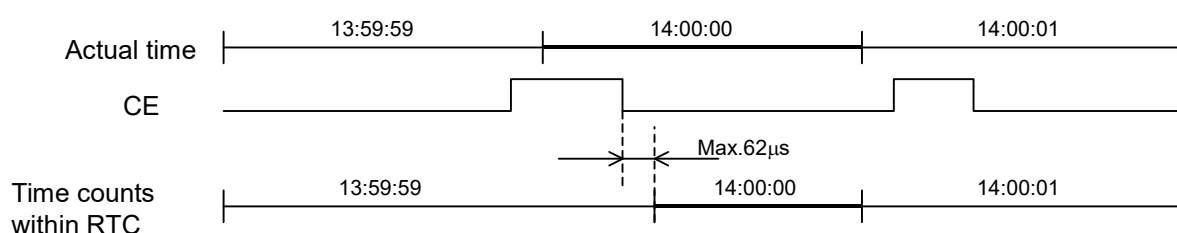

The effective use of this function requires the following considerations in reading and writing time data:

- (1) Hold the CE pin high in each session of reading or writing time data.
- (2) Ensure that the high interval of the CE pin lasts within 1 second. Should there be any possibility of the host going down in the process of reading or writing time data, make arrangements in the peripheral circuitry as to drive the CE pin low or open at the moment that the host actually goes down.
- (3) Leave a time span of 31µs or more from the low to high transition of the CE pin to the start of access to addresses 0h to 6h in order that any ongoing carry of the time digits may be completed within this time span.
- (4) Leave a time span of 62µs or more from the high to low transition of the CE pin to its low to high transition in order that any ongoing carry of the time digits during the high interval of the CE pin may be adjusted within this time span.

The considerations listed in (1), (3), and (4) above are not required when the process of reading or writing time data is obviously free from any carry of the time digits.

(e.g. reading or writing time data in synchronization with the periodic interrupt function in the level mode or the alarm interrupt function).

Good and bad examples of reading and writing time data are illustrated on the next page.

Bad Example (1)

Where the CE pin is once driven low in the process of reading time data

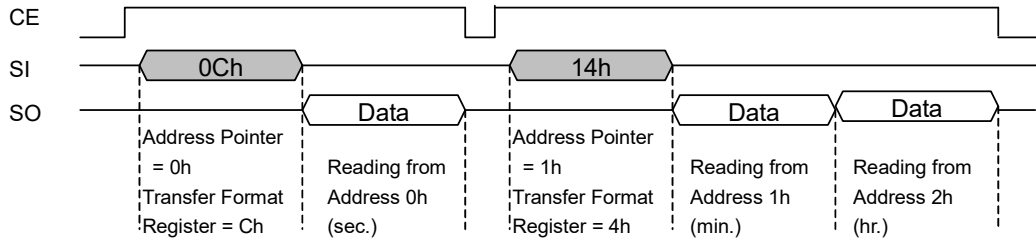

Bad Example (2)

The high interval of the CE pin is more than 1sec.

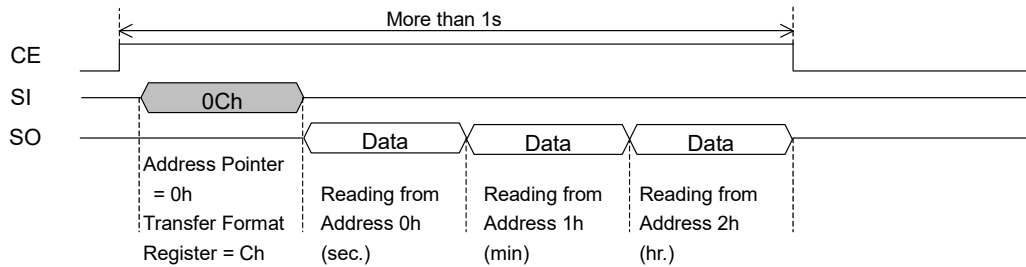

Bad Example (3)

Where a time span of less than 31µs is left until the start of the process of writing or reading time data

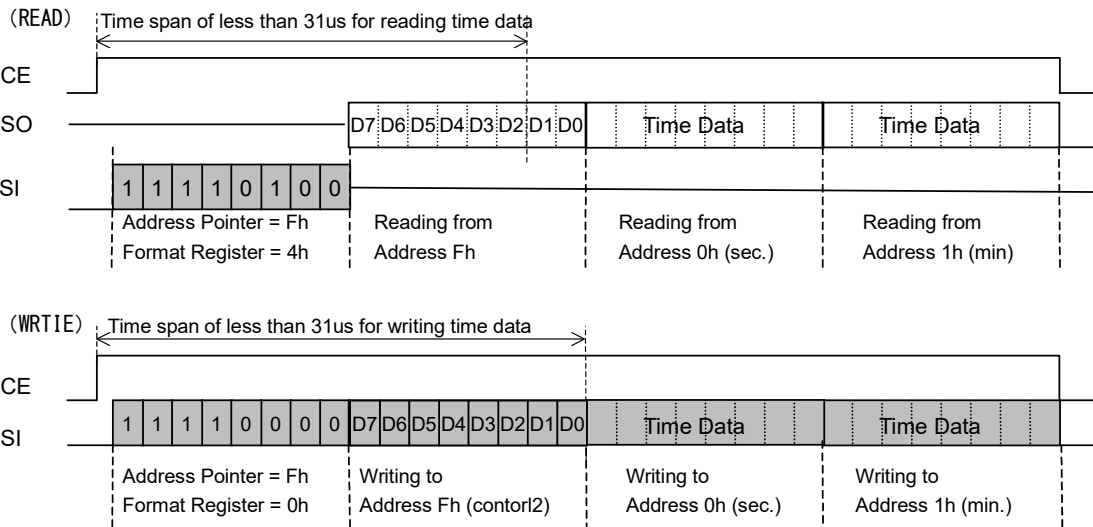

Bad Example (4)

(Where a time span of less than 61µs is left between the adjacent processes of reading time data)

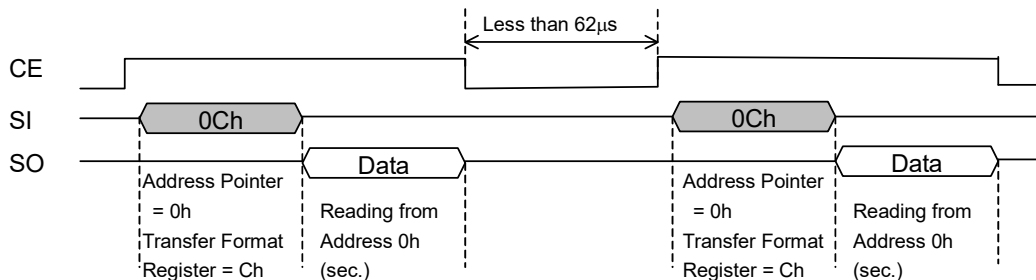

## Correction of Time Count Deviations

### • The Necessity for Correction of Time Count Deviations

The oscillation frequency for R2045S/D is corrected to  $0\pm 5\text{ppm}$  at  $25^\circ\text{C}$  in fabrication. Oscillation frequency is the fastest at  $25^\circ\text{C}$ , (Please see **Typical Characteristics** Oscillation Frequency Deviation vs. Operating temperature). In normal condition, temperature is not kept constant at  $25^\circ\text{C}$ . That is, R2045S/D loses without correction of time counts deviation. Generally, a clock is corrected to gain 3 to 6ppm at  $25^\circ\text{C}$ . R2045S/D is corrected it by setting clock adjustment register. Ricoh suggests to set 7Fh to clock adjustment register (Address 7h) for time setting to gain 3ppm at  $25^\circ\text{C}$ , for the equipment used indoors. And suggests to set 7Eh to clock adjustment register (Address 7h) for time setting to gain 6ppm at  $25^\circ\text{C}$ , for the equipment used outdoors.

### • Measurement of Oscillation Frequency

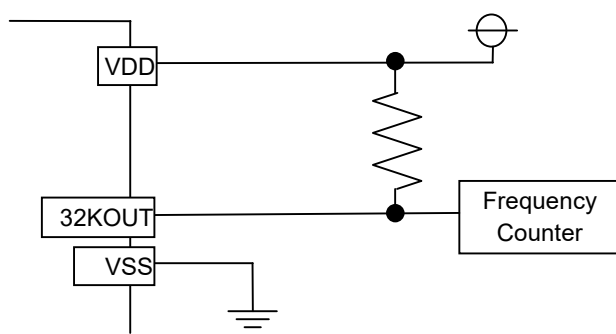

\* 1) When power-on, the R2045S/D is configured to generate 32.768-kHz clock pulses for output from the 32KOUT pin.

\* 2) A frequency counter with 6 (more preferably 7) or more digits on the order of 1ppm is recommended for use in the measurement of the oscillation frequency of the oscillation circuit.

### • Oscillation Adjustment Circuit

The oscillation adjustment circuit can be used to correct a time count gain or loss with high precision by varying the number of 1-second clock pulses once per 20 seconds. The oscillation adjustment circuit can be disabled by writing the settings of "\*", 0, 0, 0, 0, 0, "\*" ("\*" representing "0" or "1") to the F6, F5, F4, F3, F2, F1, and F0 bits in the oscillation adjustment circuit. Conversely, when such oscillation adjustment is to be made, an appropriate oscillation adjustment value can be calculated by the equation below for writing to the oscillation adjustment circuit.

(1) When Oscillation Frequency (\* 1) Is Higher Than Target Frequency (\* 2) (Causing Time Count Gain)

Oscillation adjustment value (\*3) =  $\frac{\text{Oscillation frequency} - \text{Target Frequency} + 0.1}{\text{Oscillation frequency} \times 3.051 \times 10^{-6}}$

$$\approx (\text{Oscillation Frequency} - \text{Target Frequency}) \times 10 + 1$$

\* 1) Oscillation frequency:

Frequency of clock pulse output from the 32KOUT pin at normal temperature in the manner described in "Measurement of Oscillation Frequency".

\* 2) Target frequency:

Desired frequency to be set. Generally, a 32.768-kHz crystal oscillator has such temperature characteristics as to have the highest oscillation frequency at normal temperature. Consequently, the crystal oscillator is recommended to have target frequency settings on the order of 32.768 to 32.76810 kHz (+3.05ppm relative to 32.768 kHz). Note that the target frequency differs depending on the environment or location where the equipment incorporating the RTC is expected to be operated.

\* 3) Oscillation adjustment value:

Value that is to be finally written to the F0 to F6 bits in the Oscillation Adjustment Register and is represented in 7-bit coded decimal notation.

(2) When Oscillation Frequency Is Equal To Target Frequency (Causing Time Count neither Gain nor Loss)  
Oscillation adjustment value = 0, +1, -64, or -63

(3) When Oscillation Frequency Is Lower Than Target Frequency (Causing Time Count Loss)

Oscillation adjustment value =  $\frac{\text{Oscillation frequency} - \text{Target Frequency}}{\text{Oscillation frequency} \times 3.051 \times 10^{-6}}$

$$\approx (\text{Oscillation Frequency} - \text{Target Frequency}) \times 10$$

Oscillation adjustment value calculations are exemplified below

(A) For an oscillation frequency = 32768.85Hz and a target frequency = 32768.05Hz

$$\begin{aligned} \text{Oscillation adjustment value} &= (32768.85 - 32768.05 + 0.1) / (32768.85 \times 3.051 \times 10^{-6}) \\ &\approx (32768.85 - 32768.05) \times 10 + 1 \\ &= 9.001 \approx 9 \end{aligned}$$

In this instance, write the settings ((0),F6,F5,F4,F3,F2,F1,F0)=(0,0,0,0,1,0,0,1) in the oscillation adjustment register. Thus, an appropriate oscillation adjustment value in the presence of any time count gain represents a distance from 01h.

(B) For an oscillation frequency = 32762.22Hz and a target frequency = 32768.05Hz

$$\begin{aligned} \text{Oscillation adjustment value} &= (32762.22 - 32768.05) / (32762.22 \times 3.051 \times 10^{-6}) \\ &\approx (32762.22 - 32768.05) \times 10 \\ &= -58.325 \approx -58 \end{aligned}$$

To represent an oscillation adjustment value of -58 in 7-bit coded decimal notation, subtract 58 (3Ah) from 128 (80h) to obtain 46h. In this instance, write the settings of ((0),F6,F5,F4,F3,F2,F1,F0) = (0,1,0,0,0,1,1,0) in the oscillation adjustment register. Thus, an appropriate oscillation adjustment value in the presence of any time count loss represents a distance from 80h.

Notes:

- 1) Oscillation adjustment does not affect the frequency of 32.768-kHz clock pulses output from the 32KOUT pin.
- 2) Oscillation adjustment value range: When the oscillation frequency is higher than the target frequency (causing a time count gain), an appropriate time count gain ranges from -3.05ppm to -189.2ppm with the settings of "0, 0, 0, 0, 0, 1, 0" to "0, 1, 1, 1, 1, 1, 1" written to the F6, F5, F4, F3, F2, F1, and F0 bits in the oscillation adjustment register, thus allowing correction of a time count gain of up to +189.2ppm. Conversely, when the oscillation frequency is lower than the target frequency (causing a time count loss), an appropriate time count gain ranges from +3.05ppm to +189.2ppm with the settings of "1, 1, 1, 1, 1, 1, 1" to "1, 0, 0, 0, 0, 1, 0" written to the F6, F5, F4, F3, F2, F1, and F0 bits in the oscillation adjustment register, thus allowing correction of a time count loss of up to -189.2ppm.
- 3) If following 3 conditions are completed, actual clock adjustment value could be different from target adjustment value that set by oscillator adjustment function.
  1. Using oscillator adjustment function
  2. Access to R2045S/D at random, or synchronized with external clock that has no relation to R2045S/D, or synchronized with periodic interrupt in pulse mode.
  3. Access to R2045S/D more than 2 times per each second on average.
 For more details, please contact to Ricoh.

• How to evaluate the clock gain or loss

The oscillator adjustment circuit is configured to change time counts of 1 second on the basis of the settings of the oscillation adjustment register once in 20 seconds. The oscillation adjustment circuit does not affect the frequency of 32768Hz-clock pulse output from the 32OUT pin. Therefore, after writing the oscillation adjustment register, we cannot measure the clock error with probing 32KOUT clock pulses. The way to measure the clock error as follows:

- (1) Output a 1Hz clock pulse of Pulse Mode with interrupt pin  
Set (0,0,x,x,0,0,1,1) to Control Register 1 at address Eh.

- (2) After setting the oscillation adjustment register, 1Hz clock period changes every 20seconds (or every 60 seconds) like next page figure.

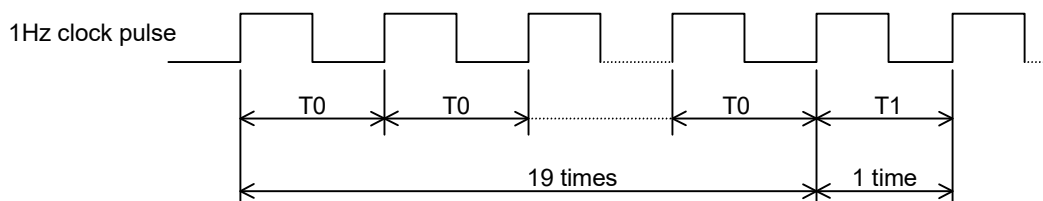

Measure the interval of T0 and T1 with frequency counter. A frequency counter with 7 or more digits is recommended for the measurement.

- (3) Calculate the typical period from T0 and T1  

$$T = (19 \times T0 + 1 \times T1) / 20$$
 Calculate the time error from T.

## Power-on Reset, Oscillation Halt Sensing, and Supply Voltage Monitoring

### • PON, $\overline{XST}$ , and VDET

The power-on reset circuit is configured to reset control register1, 2, and clock adjustment register when  $V_{DD}$  power up from 0v. The oscillation halt sensing circuit is configured to record a halt on oscillation by 32.768-kHz clock pulses. The supply voltage monitoring circuit is configured to record a drop in supply voltage below a threshold voltage of 2.1 or 1.3V.

Each function has a monitor bit. I.e. the PON bit is for the power-on reset circuit, and  $\overline{XST}$  bit is for the oscillation halt sensing circuit, and VDET is for the supply voltage monitoring circuit. PON and VDET bits are activated to "H". However,  $\overline{XST}$  bit is activated to "L". The PON and VDET accept only the writing of 0, but  $\overline{XST}$  accepts the writing of 0 and 1. The PON bit is set to 1, when VDD power-up from 0V, but VDET is set to 0, and  $\overline{XST}$  is indefinite.

The functions of these three monitor bits are shown in the table below.

	PON	$\overline{XST}$	VDET
Function	Monitoring for the power-on reset function	Monitoring for the oscillation halt sensing function	a drop in supply voltage below a threshold voltage of 2.1 or 1.3v
Address	D4 in Address Fh	D5 in Address Fh	D6 in Address Fh
Activated	High	Low	High
When VDD power up from 0v	1	indefinite	0
accept the writing	0 only	Both 0 and 1	0 only

The relationship between the PON,  $\overline{XST}$ , and VDET is shown in the table below.

PON	$\overline{XST}$	VDET	Conditions of supply voltage and oscillation	Condition of oscillator, and back-up status
0	0	0	Halt on oscillation, but no drop in VDD supply voltage below threshold voltage	Halt on oscillation cause of condensation etc.
0	0	1	Halt on oscillation and drop in VDD supply voltage below threshold voltage, but no drop to 0V	Halt on oscillation cause of drop in back-up battery voltage
0	1	0	No drop in VDD supply voltage below threshold voltage and no halt in oscillation	Normal condition
0	1	1	Drop in VDD supply voltage below threshold voltage and no halt on oscillation	No halt on oscillation, but drop in back-up battery voltage
1	*	*	Drop in supply voltage to 0v	Power-up from 0v,

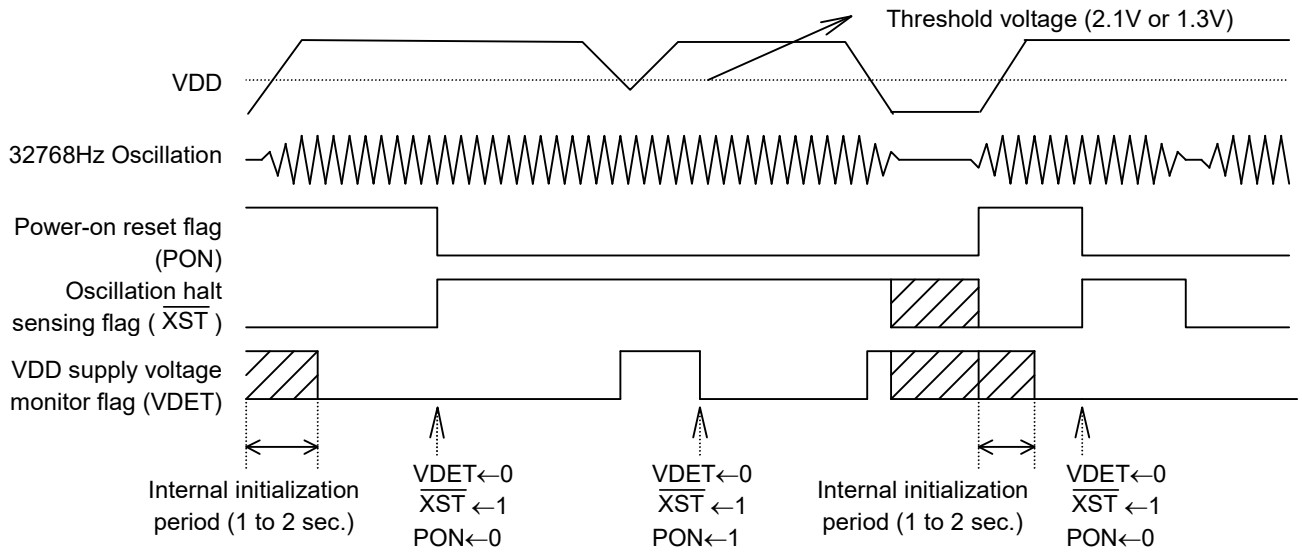

When the PON bit is set to 1 in the control register 2, the DEV, F6 to F0, WALE, DALE,  $\overline{12}/24$ ,  $\overline{CLEN2}$ , TEST, CT2, CT1, CT0, VDSL, VDET,  $\overline{CLEN1}$ , CTFG, WAFG, and DAFG bits are reset to 0 in the oscillation adjustment register, the control register 1, and the control register 2. The PON bit is also set to 1 at power-on from 0 volts.

< Considerations in Using Oscillation Halt Sensing Circuit >

Be sure to prevent the oscillation halt sensing circuit from malfunctioning by preventing the following:

- 1) Instantaneous power-down on the VDD
- 2) Applying to individual pins voltage exceeding their respective maximum ratings

In particular, note that the  $\overline{XST}$  bit may fail to be set to 0 in the presence of any applied supply voltage as illustrated below in such events as backup battery installation. Further, give special considerations to prevent excessive chattering in the oscillation halt sensing circuit.



● **Voltage Monitoring Circuit**

The VDD supply voltage monitoring circuit is configured to conduct a sampling operation during an interval of 7.8ms per second to check for a drop in supply voltage below a threshold voltage of 2.1 or 1.3V for the VDSL bit setting of 0 (the default setting) or 1, respectively, in the Control Register 2, thus minimizing supply current requirements as illustrated in the timing chart below. This circuit suspends a sampling operation once the VDET bit is set to 1 in the Control Register 2. The VDD supply voltage monitor is useful for back-up battery checking.

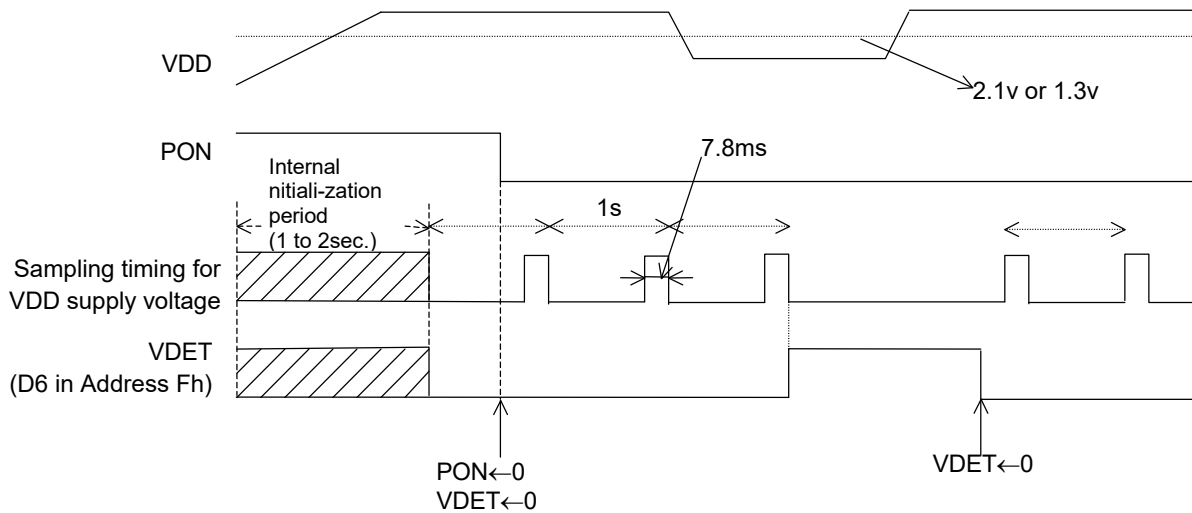

<Precautions for Using Voltage Monitoring Circuit>

After writing to the second counter, reset a VDET flag (writing 0) once for defining a value of VDET flag.



## Alarm and Periodic Interrupt

The R2045S/D incorporates the alarm interrupt circuit and the periodic interrupt circuit that are configured to generate alarm signals and periodic interrupt signals, respectively, for output from the  $\overline{\text{INTR}}$  pin as described below.

### (1) Alarm Interrupt Circuit

The alarm interrupt circuit is configured to generate alarm signals for output from the  $\overline{\text{INTR}}$ , which is driven low (enabled) upon the occurrence of a match between current time read by the time counters (the day-of-week, hour, and minute counters) and alarm time preset by the alarm registers (the Alarm\_W registers intended for the day-of-week, hour, and minute digit settings and the Alarm\_D registers intended for the hour and minute digit settings). Both The Alarm\_W and Alarm\_D are output from the  $\overline{\text{INTR}}$ .

### (2) Periodic Interrupt Circuit

The periodic interrupt circuit is configured to generate either clock pulses in the pulse mode or interrupt signals in the level mode for output from the  $\overline{\text{INTR}}$  pin depending on the CT2, CT1, and CT0 bit settings in the control register 1.

The above two types of interrupt signals are monitored by the flag bits (i.e. the WAFG, DAFG, and CTFG bits in the Control Register 2) and enabled or disabled by the enable bits (i.e. the WALE, DALE, CT2, CT1, and CT0 bits in the Control Register 1) as listed in the table below.

	Flag bits	Enable bits
Alarm_W	WAFG (D1 at Address Fh)	WALE (D7 at Address Eh)
Alarm_D	DAFG (D0 at Address Fh)	DALE (D6 at Address Eh)
Peridic Interrupt	CTFG (D2 at Address Fh)	CT2=CT1=CT0=0 (These bit setting of "0" disable the Periodic Interrupt) (D2 to D0 at Address Eh)

\* At power-on, when the WALE, DALE, CT2, CT1, and CT0 bits are set to 0 in the Control Register 1, the  $\overline{\text{INTR}}$  pin is driven high (disabled).

\* When two types of interrupt signals are output simultaneously from the  $\overline{\text{INTR}}$  pin, the output from the  $\overline{\text{INTR}}$  pin becomes an OR waveform of their negative logic.

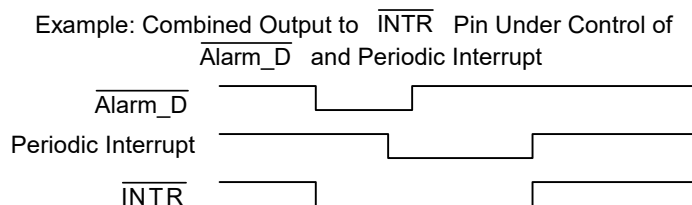

In this event, which type of interrupt signal is output from the  $\overline{\text{INTR}}$  pin can be confirmed by reading the DAFG, and CTFG bit settings in the Control Register 2.

• Alarm Interrupt

The alarm interrupt circuit is controlled by the enable bits (i.e. the WALE and DALE bits in the Control Register 1) and the flag bits (i.e. the WAFG and DAFG bits in the Control Register 2). The enable bits can be used to enable this circuit when set to 1 and to disable it when set to 0. When intended for reading, the flag bits can be used to monitor alarm interrupt signals. When intended for writing, the flag bits will cause no event when set to 1 and will drive high (disable) the alarm interrupt circuit when set to 0.

The enable bits will not be affected even when the flag bits are set to 0. In this event, therefore, the alarm interrupt circuit will continue to function until it is driven low (enabled) upon the next occurrence of a match between current time and preset alarm time.

The alarm function can be set by presetting desired alarm time in the alarm registers (the Alarm\_W Registers for the day-of-week digit settings and both the Alarm\_W Registers and the Alarm\_D Registers for the hour and minute digit settings) with the WALE and DALE bits once set to 0 and then to 1 in the Control Register 1. Note that the WALE and DALE bits should be once set to 0 in order to disable the alarm interrupt circuit upon the coincidental occurrence of a match between current time and preset alarm time in the process of setting the alarm function.

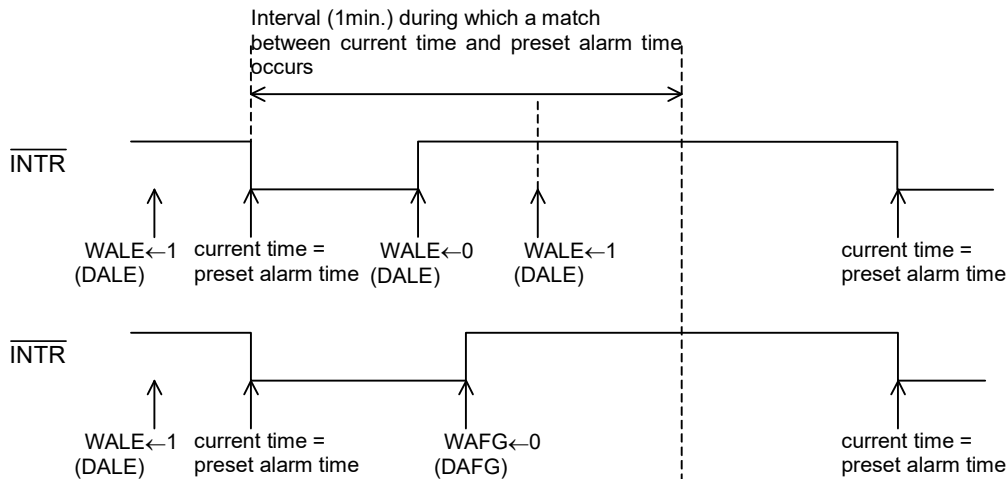

## • Periodic Interrupt

Setting of the periodic selection bits (CT2 to CT0) enables periodic interrupt to the CPU. There are two waveform modes: pulse mode and level mode. In the pulse mode, the output has a waveform duty cycle of around 50%. In the level mode, the output is cyclically driven low and, when the CTFG bit is set to 0, the output is return to High (OFF).

CT2	CT1	CT0	Description	
			Wave form mode	Interrupt Cycle and Falling Timing
0	0	0	-	OFF(H)
0	0	1	-	Fixed at "L"
0	1	0	Pulse Mode *1)	2Hz(Duty50%)
0	1	1	Pulse Mode *1)	1Hz(Duty50%)
1	0	0	Level Mode *2)	Once per 1 second (Synchronized with Second counter increment)
1	0	1	Level Mode *2)	Once per 1 minute (at 00 seconds of every Minute)
1	1	0	Level Mode *2)	Once per hour (at 00 minutes and 00 Seconds of every hour)
1	1	1	Level Mode *2)	Once per month (at 00 hours, 00 minutes, and 00 seconds of first day of every month)

(Default)

\*1) Pulse Mode: 2-Hz and 1-Hz clock pulses are output in synchronization with the increment of the second counter as illustrated in the timing chart below.

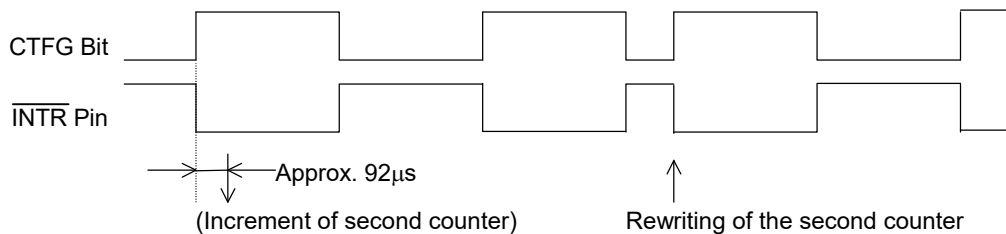

In the pulse mode, the increment of the second counter is delayed by approximately 92 μs from the falling edge of clock pulses. Consequently, time readings immediately after the falling edge of clock pulses may appear to lag behind the time counts of the real-time clocks by approximately 1 second. Rewriting the second counter will reset the other time counters of less than 1 second, driving the  $\overline{\text{INTR}}$  pin low.

\*2) Level Mode: Periodic interrupt signals are output with selectable interrupt cycle settings of 1 second, 1 minute, 1 hour, and 1 month. The increment of the second counter is synchronized with the falling edge of periodic interrupt signals. For example, periodic interrupt signals with an interrupt cycle setting of 1 second are output in synchronization with the increment of the second counter as illustrated in the timing chart below.

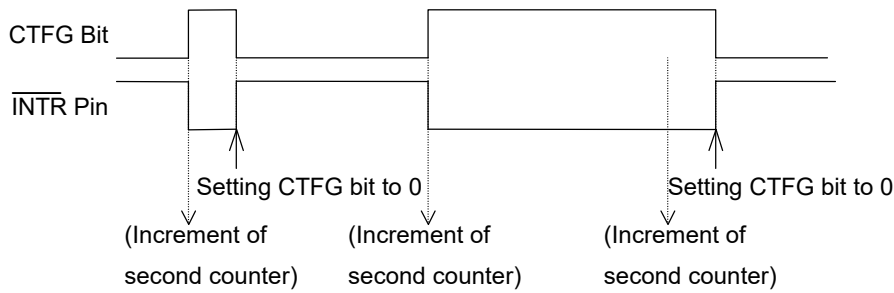

\*1), \*2) When the oscillation adjustment circuit is used, the interrupt cycle will fluctuate once per 20sec. as follows:

Pulse Mode: The "L" period of output pulses will increment or decrement by a maximum of  $\pm 3.784$ ms. For example, 1-Hz clock pulses will have a duty cycle of  $50 \pm 0.3784\%$ .

Level Mode: A periodic interrupt cycle of 1 second will increment or decrement by a maximum of  $\pm 3.784$  ms.

### 32-kHz CLOCK OUTPUT

For the R2045S/D, 32.768-kHz clock pulses are output from the 32KOUT pin when  $\overline{\text{CLEN1}}$  or  $\overline{\text{CLEN2}}$  bit is set to Low. If  $\overline{\text{CLEN1}}$  and  $\overline{\text{CLEN2}}$  are set to high, the 32KOUT pin is high impedance.

$\overline{\text{CLEN1}}$ bit (D3 at Address Fh)	$\overline{\text{CLEN2}}$ bit (D4 at Address Eh)	32KOUT output pin (N-channel open drain output)
1	1	OFF(H)
0(Default)	*	32kHz clock output
*	0(Default)	

The 32KOUT pin output is synchronized with the  $\overline{\text{CLEN1}}$  and  $\overline{\text{CLEN2}}$  bit settings as illustrated in the timing chart below.

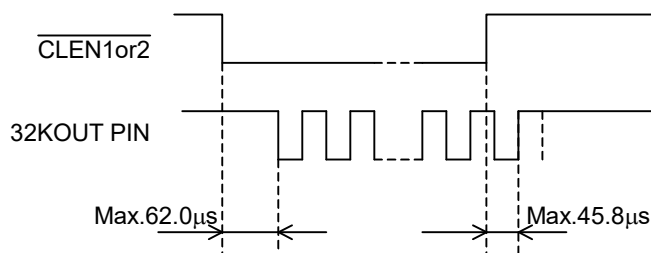

## Typical Applications

### • Typical Power Circuit Configurations

Sample circuit configuration 1

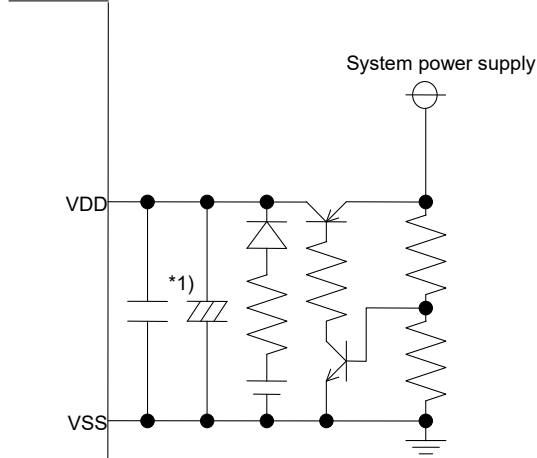

\*1) Install bypass capacitors for high frequency and low frequency applications in parallel in close vicinity to the R2045S/D.

Sample circuit configuration 2

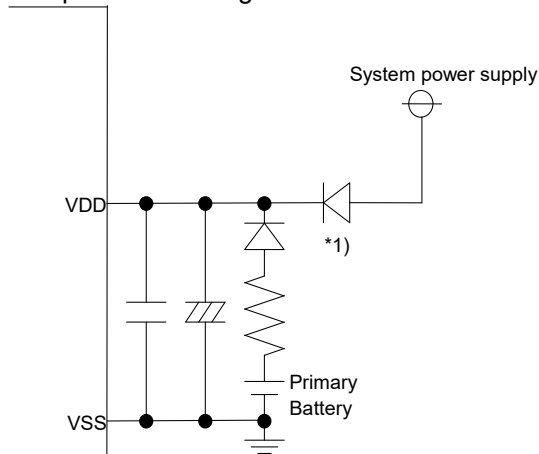

\*1) When using an OR diode as a power supply for the R2045S/D ensure that voltage exceeding the absolute maximum rating of  $V_{DD}+0.3V$  is not applied to the SO pin.

Sample circuit configuration 3

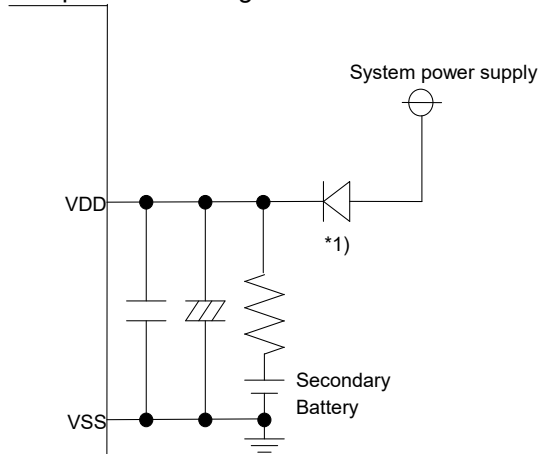

• **Connection of  $\overline{\text{INTR}}$  Pin**

The  $\overline{\text{INTR}}$  pin follows the N-channel open drain output logic and contains no protective diode on the power supply side. As such, it can be connected to a pull-up resistor of up to 5.5 volts regardless of supply voltage.

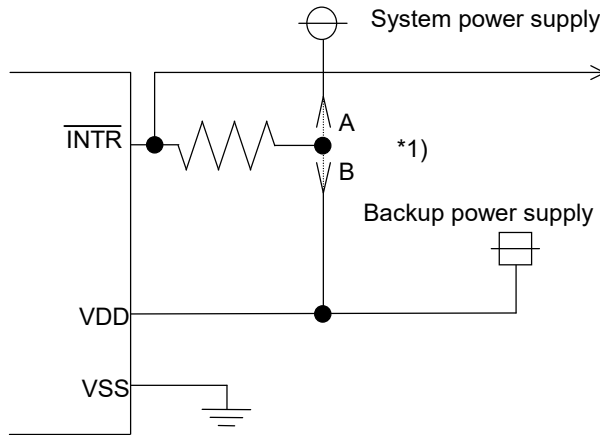

\*1) Depending on whether the  $\overline{\text{INTR}}$  pin is to be used during battery backup, it should be connected to a pull-up resistor at the following different positions:

- (1) Position A in the left diagram when it is not to be used during battery backup.
- (2) Position B in the left diagram when it is to be used during battery backup.

• **Connection of 32KOUT Pin**

The 32KOUT pin follows the Nch. open drain output and contains no protective diode on the power supply side. As such, it can be connected to a device with a supply voltage of up to 5.5 volts regardless of supply voltage, provided that such connection involves considerations for the supply current requirements of a pull-up resistor, which can be roughly calculated by the following equation:

$$I = 0.5 \times (V_{DD} \text{ or } V_{CC}) / R_p$$

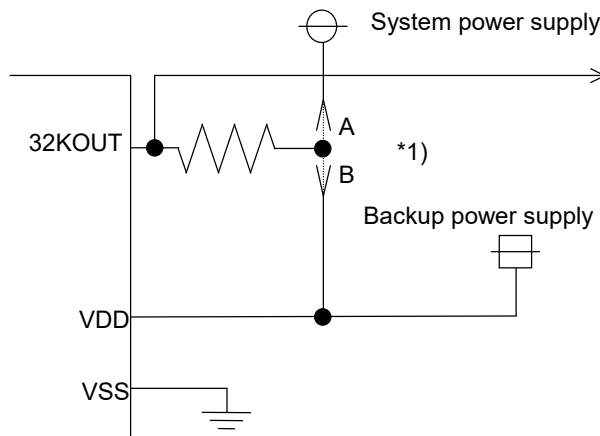

\*1) Depending on whether the 32KOUT pin is to be used during battery backup, it should be connected to a pull-up resistor at the following different positions:

- (1) Position A in the left diagram when it is not to be used during battery backup.
- (2) Position B in the left diagram when it is to be used during battery backup.

• **Connection of CE Pin**

Connection of the CE pin requires the following considerations:

- 1) The CE pin is configured to enable the oscillation halt sensing circuit only when driven low. As such, it should be driven low or open at power-on from 0 volts.
- 2) The CE pin should also be driven low or open immediately upon the host going down (see "**Considerations in Reading and Writing Time Data under special condition**").

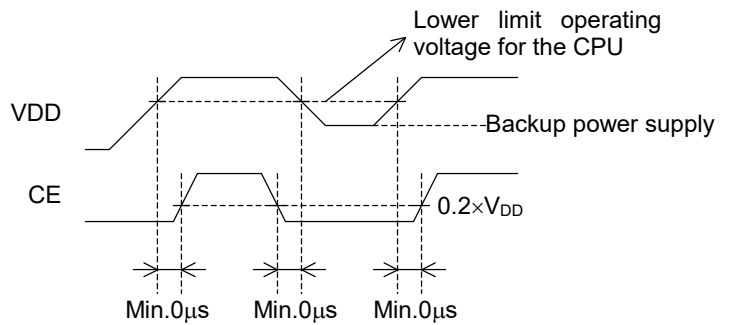
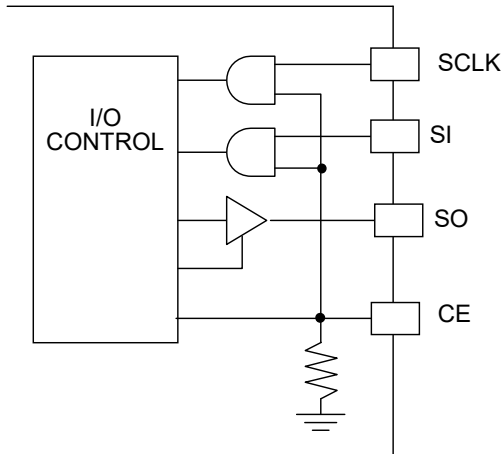

• **Connection With 3-Wire Serial Interface Bus**

To connect the R2045S/D with 3-wire serial interface bus, shorten the SI and SO pins and connect them to the data line as shown in the figure below.

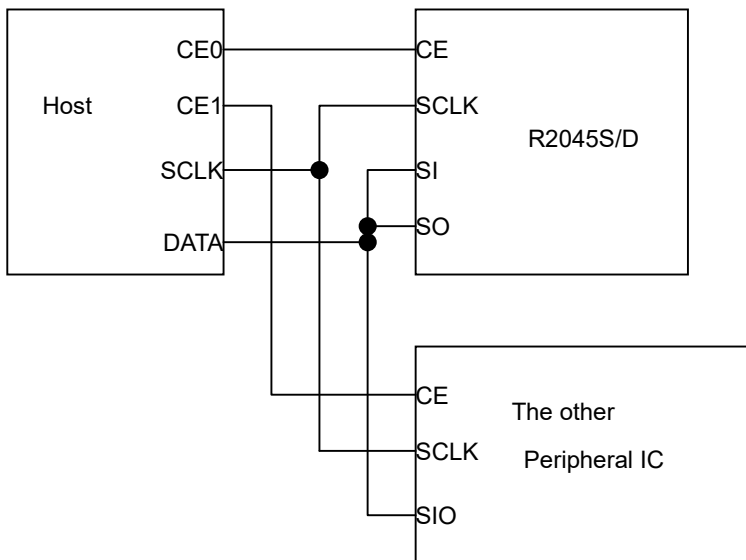

## Typical Characteristics

Test Circuit

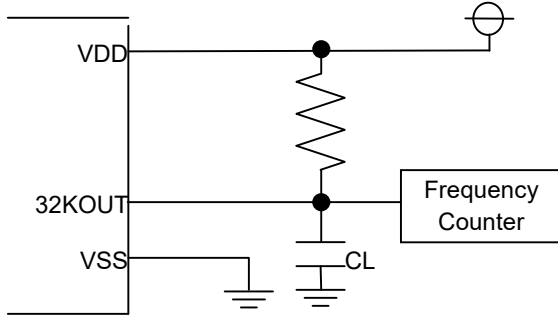

Topt : 25°C  
Output : Open

Timekeeping current vs. Supply Voltage  
(with no 32-kHz clock output)  
(Output=Open, Topt=25°C)

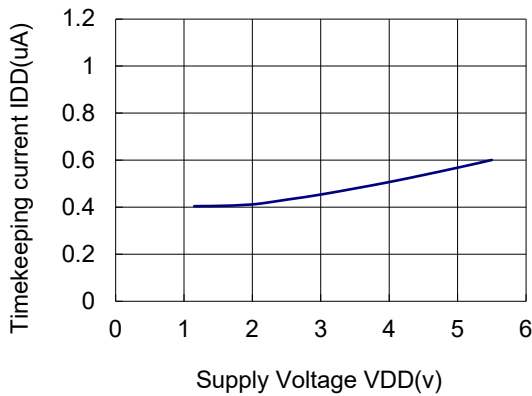

Timekeeping current vs. Supply Voltage  
(with 32-kHz clock output)  
(Output=Open, Topt=25°C)

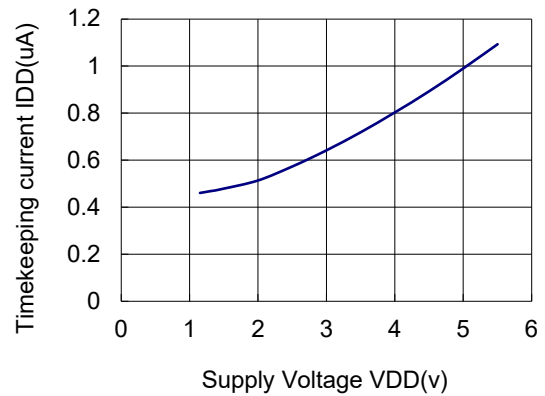

CPU Access Current vs. SCL Clock Frequency  
(Output=Open, Topt=25°C)  
(without pull-up resistor current)

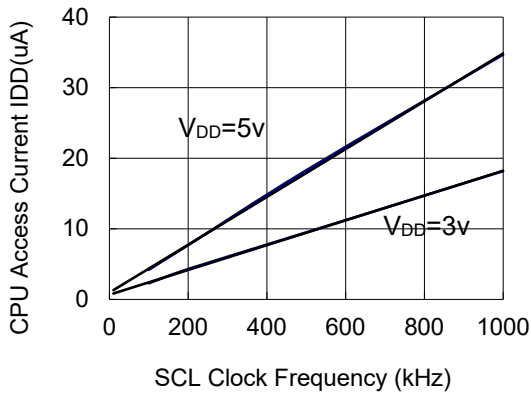

Timekeeping current vs. Operating Temperature  
(Output=Open, VDD=3V)

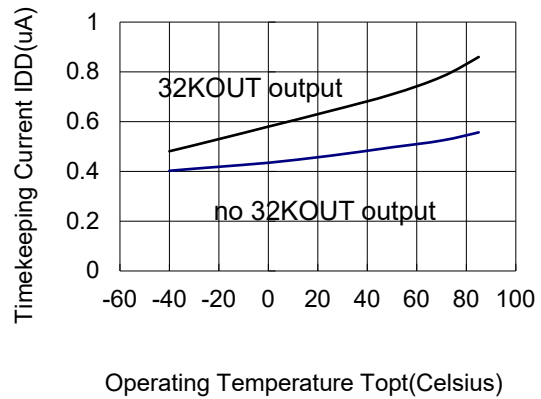



Oscillation Frequency Deviation vs. Supply Voltage  
( $T_{opt}=25^{\circ}\text{C}$ )

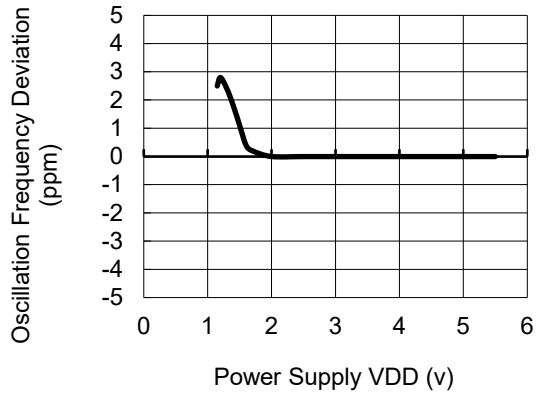

Oscillation Frequency Deviation vs. Operating Temperature  
( $V_{DD}=3\text{v}$ )

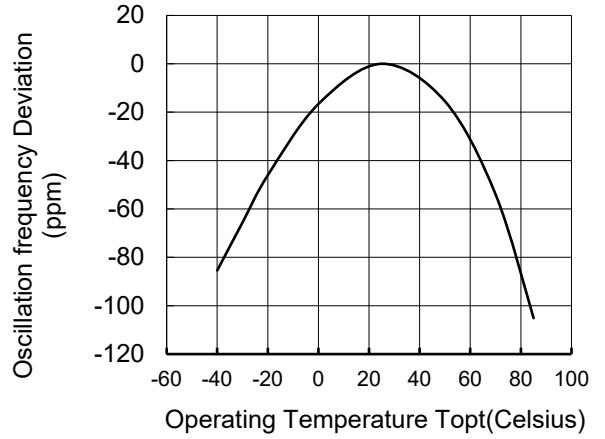

$V_{OL}$  vs.  $I_{OL}$  ( $\overline{\text{INTR}}$  pin)  
( $T_{opt}=25^{\circ}\text{C}$ )

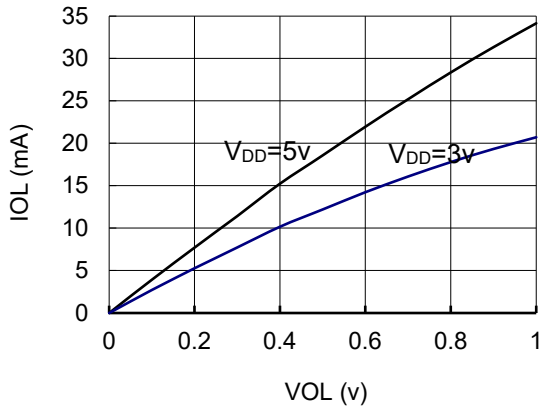

$V_{OL}$  vs.  $I_{OL}$  ( $\overline{\text{INTR}}$  pin)  
( $V_{IN}=V_{DD}, T_{opt}=25^{\circ}\text{C}$ )

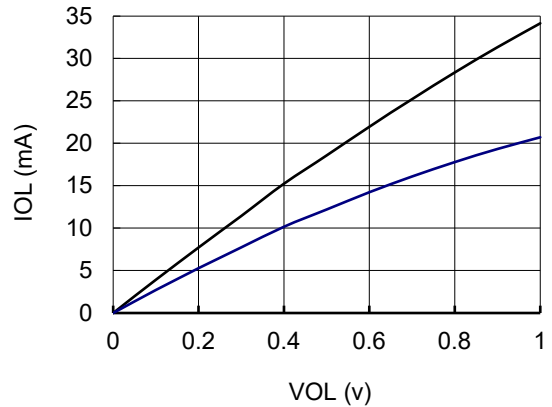

Oscillation Start Time vs. Power Supply  
( $T_{opt}=25^{\circ}\text{C}$ )

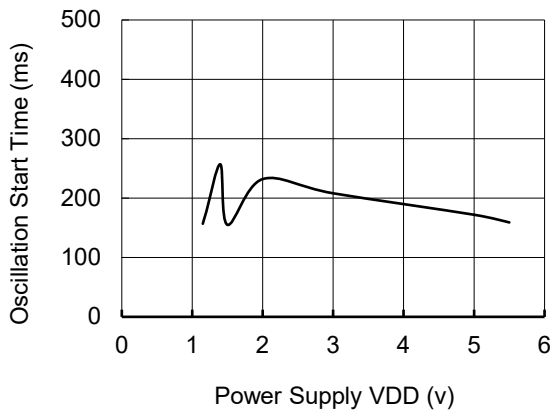

## Typical Software-based Operations

### • Initialization at Power-on

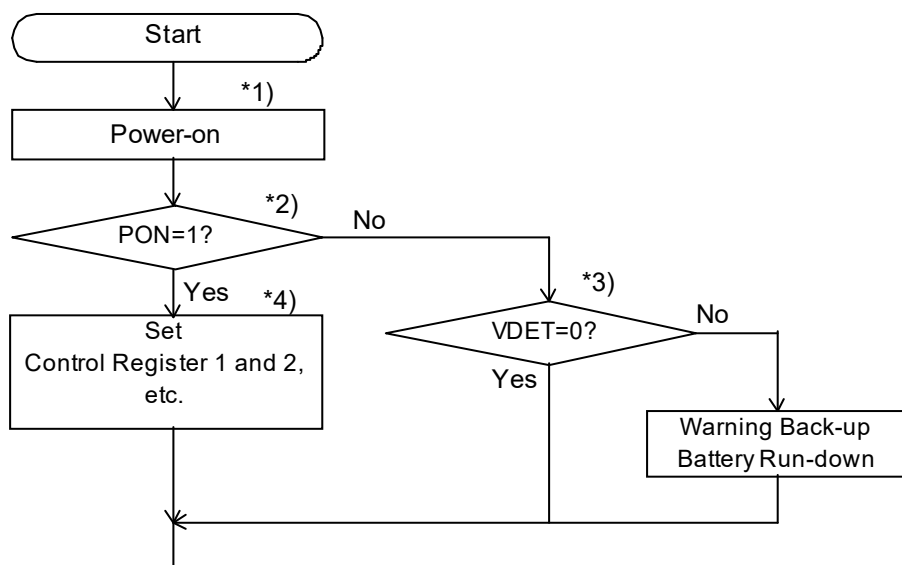

\*1) After power-on from 0 volt, the start of oscillation and the process of internal initialization require a time span on the order of 1 to 2sec, so that access should be done after the lapse of this time span or more.

\*2) The PON bit setting of 0 in the Control Register 1 indicates power-on from backup battery and not from 0v. For further details, see "**Power-on Reset, Oscillation Halt Sensing, and Supply Voltage Monitoring • PON,  $\overline{XST}$ , and VDET**".

\*3) This step is not required when the supply voltage monitoring circuit is not used.

When using this circuit, note as follows.

After writing to the second counter, reset a VDET flag (writing 0) once for defining a value of VDET flag.

\*4) This step involves ordinary initialization including the Oscillation Adjustment Register and interrupt cycle settings, etc.

• **Writing of Time and Calendar Data**

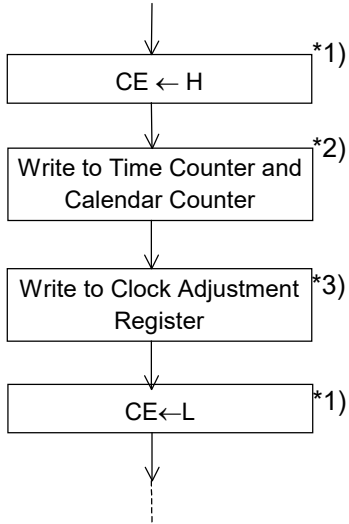

\*1) When writing to clock and calendar counters, do not drive CE to L until all times from second to year have been written to prevent error in writing time. For more detailed in "**Considerations in Reading and Writing Time Data under special condition**".

\*2) Any writing to the second counter will reset divider units lower than the second digits. After writing to the second counter, reset a VDET flag (writing 0) once for defining a value of VDET flag.

\*3) Please see "**The Necessity for Correction of Time Count Deviations**"

The R2045S/D may also be initialized not at power-on but in the process of writing time and calendar data.

• **Reading Time and Calendar Data**

(1) Ordinary Process of Reading Time and Calendar Data

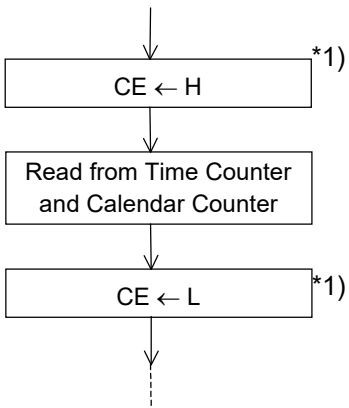

\*1) When reading clock and calendar counters, do not drive CE to L until all times from second to year have been written to prevent error in writing time. For more detailed in "**Considerations in Reading and Writing Time Data under special condition**".

(2) Basic Process of Reading Time and Calendar Data with Periodic Interrupt Function

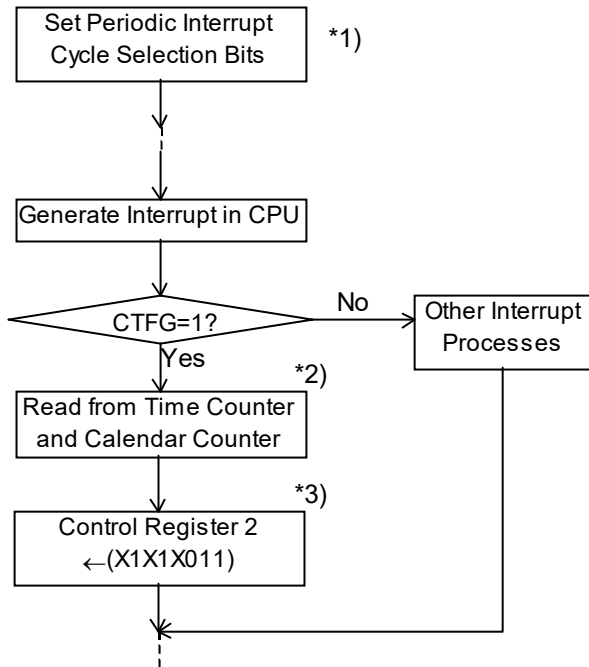

\*1) This step is intended to select the level mode as a waveform mode for the periodic interrupt function.

\*2) This step must be completed within 1.0 second.

\*3) This step is intended to set the CTFG bit to 0 in the Control Register 2 to cancel an interrupt to the CPU.

(3) Applied Process of Reading Time and Calendar Data with Periodic Interrupt Function

Time data need not be read from all the time counters when used for such ordinary purposes as time count indication. This applied process can be used to read time and calendar data with substantial reductions in the load involved in such reading.

For Time Indication in "Day-of-Month, Day-of-week, Hour, Minute, and Second" Format:

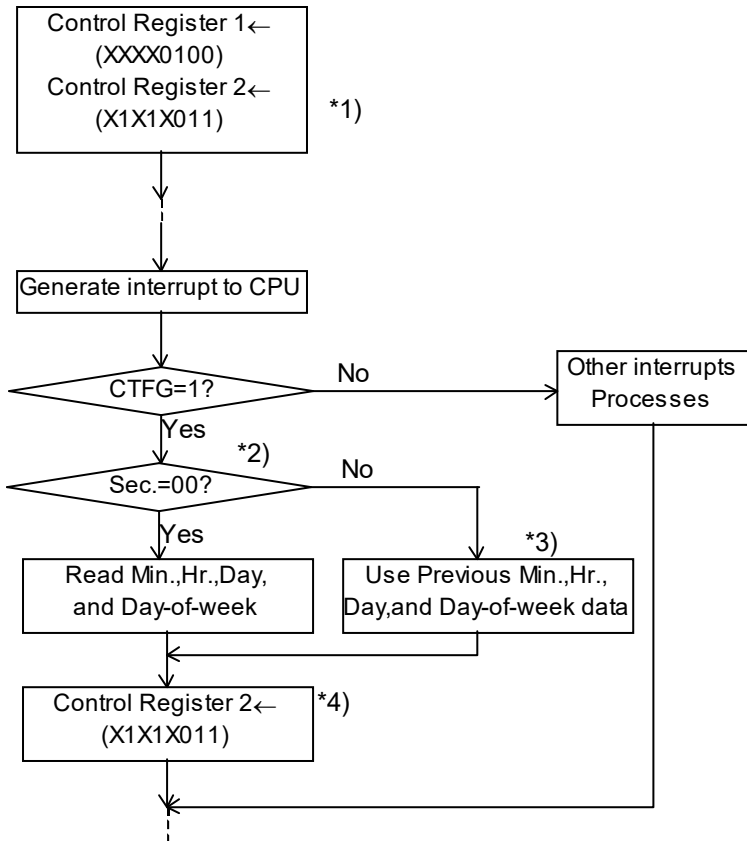

\*1) This step is intended to select the level mode as a waveform mode for the periodic interrupt function.

\*2) This step must be completed within 1.0 sec.

\*3) This step is intended to read time data from all the time counters only in the first session of reading time data after writing time data.

\*4) This step is intended to set the CTFG bit to 0 in the Control Register 2 to cancel an interrupt to the CPU.

● **Interrupt Process**

(1) Periodic Interrupt

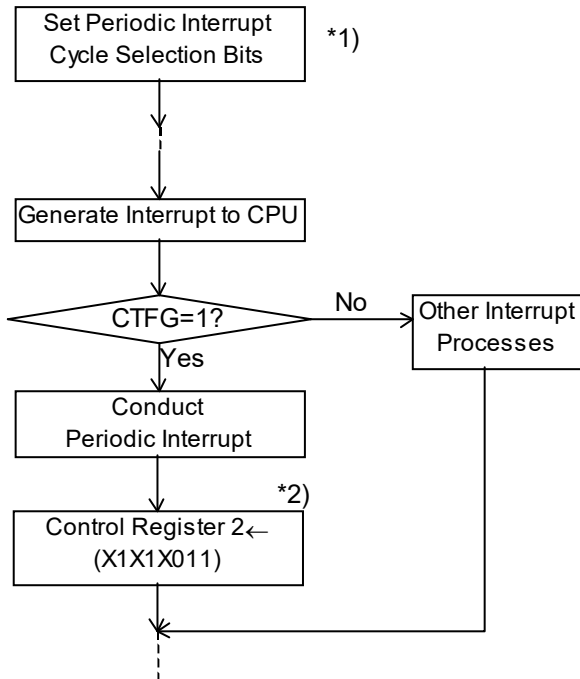

\*1) This step is intended to select the level mode as a waveform mode for the periodic interrupt function.

\*2) This step is intended to set the CTFG bit to 0 in the Control Register 2 to cancel an interrupt to the CPU.

(2) Alarm Interrupt

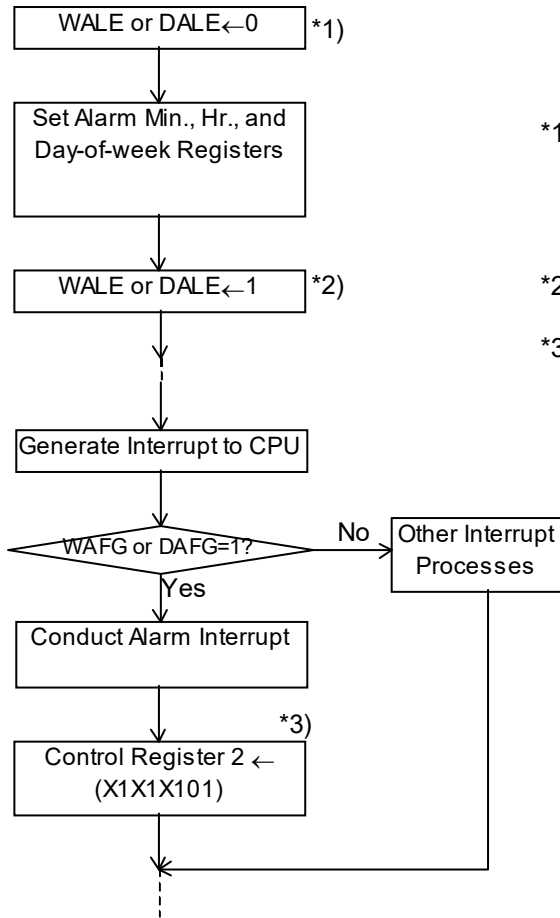

\*1) This step is intended to once disable the alarm interrupt circuit by setting the WALE or DALE bits to 0 in anticipation of the coincidental occurrence of a match between current time and preset alarm time in the process of setting the alarm interrupt function.

\*2) This step is intended to enable the alarm interrupt function after completion of all alarm interrupt settings.

\*3) This step is intended to once cancel the alarm interrupt function by writing the settings of "X,1,X, 1,X,1,0,1" and "X,1,X,1,X,1,1,0" to the Alarm\_W Registers and the Alarm\_D Registers, respectively.

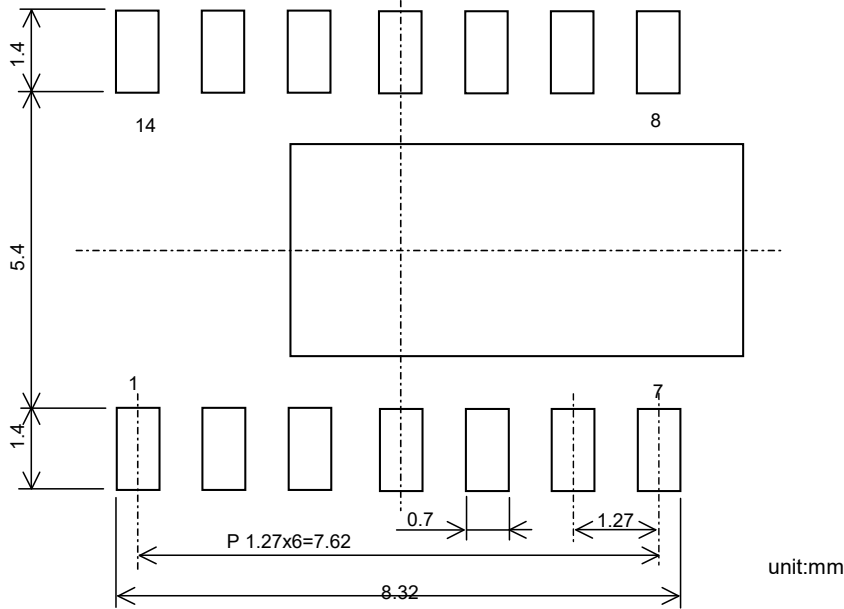

## Land Pattern (reference)

### • R2045S (SOP14)

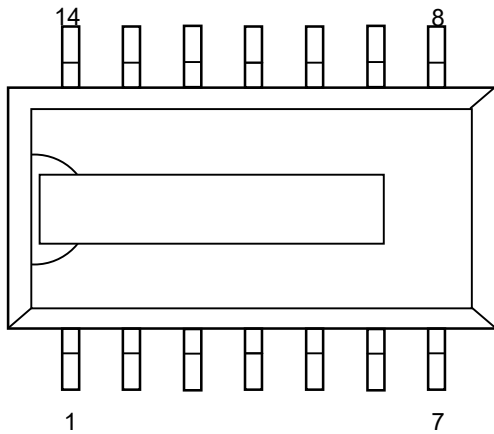

Package top view







1. Pad layout and size can modify by customers material, equipment, and method. Please adjust pad layout according to your conditions.
2. In the mount area which described as , is close to the inside oscillator circuit. To avoid the malfunction by noise, check the other signal lines close to the area, do not intervene with the oscillator circuit.
3. A part of a metal case of the crystal may be seen in the area which described as  in both sides of the package. It has no influence on the characteristics and quality of the product.

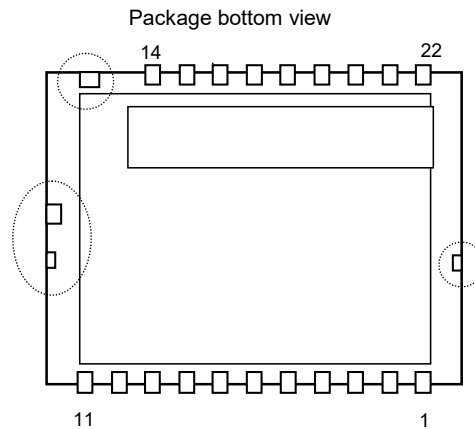
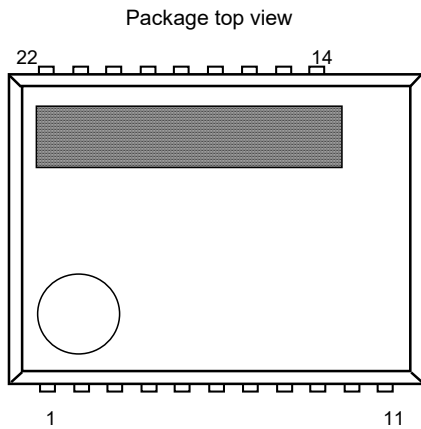
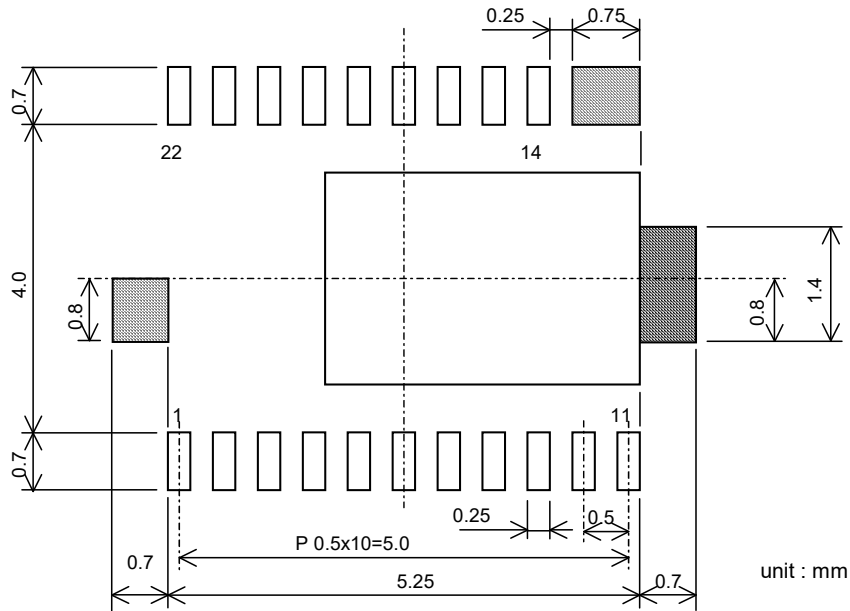

● R2045D (SON22)



1. Pad layout and size can modify by customers material, equipment, and method. Please adjust pad layout according to your conditions.
2. Any signal line should not pass through the area that described as  in the land pattern. If a signal line is located in that area, it may cause a short circuit with a tab suspension leads which is marked with  in the figure above or unnecessary remainder of cut lead.
3. In the mount area which described as , is close to the inside oscillator circuit. To avoid the malfunction by noise, check the other signal lines close to the area, do not intervene with the oscillator circuit.
4. A part of a metal case of the crystal may be seen in the area that described as  in both sides of the package. It has no influence on the characteristics and quality of the product.

1. The products and the product specifications described in this document are subject to change or discontinuation of production without notice for reasons such as improvement. Therefore, before deciding to use the products, please refer to our sales representatives for the latest information thereon.
2. The materials in this document may not be copied or otherwise reproduced in whole or in part without the prior written consent of us.
3. This product and any technical information relating thereto are subject to complementary export controls (so-called KNOW controls) under the Foreign Exchange and Foreign Trade Law, and related political ministerial ordinance of the law. (Note that the complementary export controls are inapplicable to any application-specific products, except rockets and pilotless aircraft, that are insusceptible to design or program changes.) Accordingly, when exporting or carrying abroad this product, follow the Foreign Exchange and Foreign Trade Control Law and its related regulations with respect to the complementary export controls.
4. The technical information described in this document shows typical characteristics and example application circuits for the products. The release of such information is not to be construed as a warranty of or a grant of license under our or any third party's intellectual property rights or any other rights.
5. The products listed in this document are intended and designed for use as general electronic components in standard applications (office equipment, telecommunication equipment, measuring instruments, consumer electronic products, amusement equipment etc.). Those customers intending to use a product in an application requiring extreme quality and reliability, for example, in a highly specific application where the failure or misoperation of the product could result in human injury or death should first contact us.
  - Aerospace Equipment
  - Equipment Used in the Deep Sea
  - Power Generator Control Equipment (nuclear, steam, hydraulic, etc.)
  - Life Maintenance Medical Equipment
  - Fire Alarms / Intruder Detectors
  - Vehicle Control Equipment (automotive, airplane, railroad, ship, etc.)
  - Various Safety Devices
  - Traffic control system
  - Combustion equipment

In case your company desires to use this product for any applications other than general electronic equipment mentioned above, make sure to contact our company in advance. Note that the important requirements mentioned in this section are not applicable to cases where operation requirements such as application conditions are confirmed by our company in writing after consultation with your company.

6. We are making our continuous effort to improve the quality and reliability of our products, but semiconductor products are likely to fail with certain probability. In order to prevent any injury to persons or damages to property resulting from such failure, customers should be careful enough to incorporate safety measures in their design, such as redundancy feature, fire containment feature and fail-safe feature. We do not assume any liability or responsibility for any loss or damage arising from misuse or inappropriate use of the products.
7. The products have been designed and tested to function within controlled environmental conditions. Do not use products under conditions that deviate from methods or applications specified in this datasheet. Failure to employ the products in the proper applications can lead to deterioration, destruction or failure of the products. We shall not be responsible for any bodily injury, fires or accident, property damage or any consequential damages resulting from misuse or misapplication of the products.
8. **Quality Warranty**
  - 8-1. **Quality Warranty Period**

In the case of a product purchased through an authorized distributor or directly from us, the warranty period for this product shall be one (1) year after delivery to your company. For defective products that occurred during this period, we will take the quality warranty measures described in section 8-2. However, if there is an agreement on the warranty period in the basic transaction agreement, quality assurance agreement, delivery specifications, etc., it shall be followed.
  - 8-2. **Quality Warranty Remedies**

When it has been proved defective due to manufacturing factors as a result of defect analysis by us, we will either deliver a substitute for the defective product or refund the purchase price of the defective product.

Note that such delivery or refund is sole and exclusive remedies to your company for the defective product.
  - 8-3. **Remedies after Quality Warranty Period**

With respect to any defect of this product found after the quality warranty period, the defect will be analyzed by us. On the basis of the defect analysis results, the scope and amounts of damage shall be determined by mutual agreement of both parties. Then we will deal with upper limit in Section 8-2. This provision is not intended to limit any legal rights of your company.
9. Anti-radiation design is not implemented in the products described in this document.
10. The X-ray exposure can influence functions and characteristics of the products. Confirm the product functions and characteristics in the evaluation stage.
11. WLCSP products should be used in light shielded environments. The light exposure can influence functions and characteristics of the products under operation or storage.
12. Warning for handling Gallium and Arsenic (GaAs) products (Applying to GaAs MMIC, Photo Reflector). These products use Gallium (Ga) and Arsenic (As) which are specified as poisonous chemicals by law. For the prevention of a hazard, do not burn, destroy, or process chemically to make them as gas or power. When the product is disposed of, please follow the related regulation and do not mix this with general industrial waste or household waste.
13. Please contact our sales representatives should you have any questions or comments concerning the products or the technical information.



**Nisshinbo Micro Devices Inc.**

**Official website**

<https://www.nisshinbo-microdevices.co.jp/en/>

**Purchase information**

<https://www.nisshinbo-microdevices.co.jp/en/buy/>