

- 1
- 2
- 3
- 4
- 5
- 6
- 7
- 8
- 9
- 10
- 11
- 12
- 13
- 14
- 15
- 16
- 17
- 18

MATERIAL

Glass-fibre reinforced polyamide based (PA) technopolymer, grey-black colour, matte finish.

HUB CAP

- ECM.K: glass-fibre reinforced polyamide based (PA) technopolymer, in Elecolors colours, matte finish, press-fit assembly. Supplied. Available also as accessory sold separately (see table).

STANDARD EXECUTION

Black-oxide steel hub, H7 reamed hole.
Revolving handle l.621+x (see page 406) in technopolymer.

FEATURES AND APPLICATIONS

The reticular structure of the crank arm and the technopolymer used make this handle very strong and therefore suitable for transmitting high torque values.

ACCESSORIES ON REQUEST

- GN 184: axial retaining washer in black-oxide steel (see page 897).
- ECM.K: glass-fibre reinforced polyamide based (PA) technopolymer hub cap, in Elecolors colours, matte finish, press-fit assembly (see table).



- C1**
RAL7021
- C2**
RAL2004
- C3**
RAL7035
- C4**
RAL1021
- C5**
RAL5024
- C6**
RAL3000

ERGOSTYLE® ELESA Original design



ECM.K

Code	Description	Hub cap for
29633-*	ECM.K3-*	EKH.100
29634-*	ECM.K4-*	EKH.125

* Complete with colour index (C1, ..., C6).

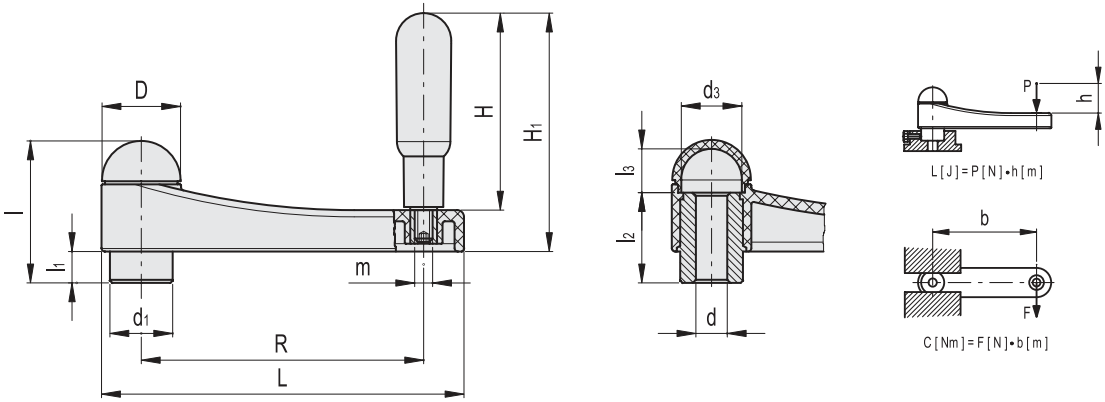

Conversion Table	
1 mm = 0.039 inch	
R	
mm	inch
101	3.98
126	4.96



* Complete with colour index, example: 210241-C2 EKH.100 A-12-C2

- C1**
RAL7021
- C2**
RAL2004
- C3**
RAL7035
- C4**
RAL1021
- C5**
RAL5024
- C6**
RAL3000

Code	Description	R	dH7	L	D	d1	d3	l	l1	l2	l3	H	H1	m	C# [Nm]	L# [J]	⚖️
210241-*	EKH.100 A-12-*	101	12	131.5	30.5	24	23.5	52.5	10	33	17	65	81	M8	200	27	231
210251-*	EKH.125 A-14-*	126	14	161.5	35	28	26.5	62	14	40	18	80	98.5	M8	350	45	316

For maximum applicable torque (C) and impact strength (L) see Technical data on page A-3.