

DP83825EVM User's Guide

This User's Guide discusses how to properly operate and configure the DP83825EVM.

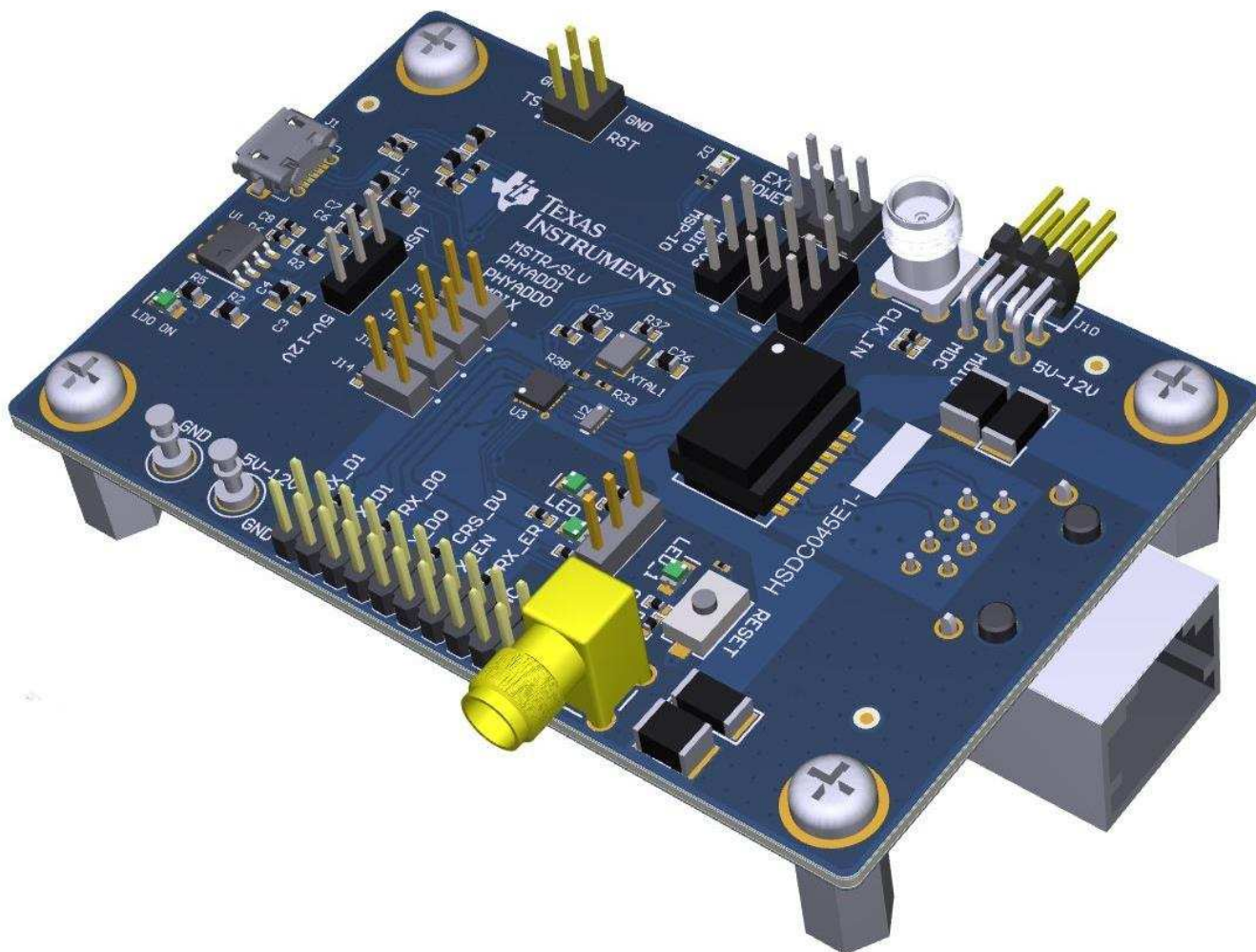

Contents

1	Definitions	2
2	Introduction	3
3	Board Setup Details	8
4	Configurations Options	9
5	REACH Compliance	12

List of Figures

1	DP83825EVM – Top Side	3
2	DP83825EVM – Bottom Side	4
3	LDO Operation	5
4	Supply Selection Jumpers - LDO	6
5	Supply Selection Jumpers - LDO	6
6	DP83825EVM Block Diagram	8
7	Strap Pins	10
8	LED_0 Strap	10

List of Tables

1	Terminology	2
2	EVM Applications	9
3	Strap Value	9
4	Strap Options Table	11

Trademarks

All trademarks are the property of their respective owners.

1 Definitions

Table 1. Terminology

ACRONYM	DEFINITION
PHY	Physical Layer Transceiver
MAC	Media Access Controller
SMI	Serial Management Interface
MDIO	Management Data I/O
MDC	Management Data Clock
RGMII	Reduced Gigabit Media Independent Interface
SFD	Start-of-Frame Detection
VDDA	Analog Core Supply Rail
VDDIO	Digital Supply Rail
PD	Pulldown
PU	Pullup
MC	Microcontroller

2 Introduction

The DP83825 is a smallest form factor, lowest power Ethernet Physical Layer transceiver with integrated PMD sublayers to support 10BASE-Te, 100BASE-TX Ethernet protocols. The DP83825 interfaces directly to twisted pair media via an external transformer. It interfaces to the MAC layer through Reduced MII (RMII) both in Master and Slave mode. 50 MHz clock in RMII Master mode is synchronized to MDI derived clock to improve the jitter in the system. The DP83825EVM will demonstrate all features of DP83825. The EVM will support 10BASE-Te and 100BASE-TX Ethernet protocols. The EVM will have connections to use the DP83825 RMII pins through header pins.

2.1 Key Features

- 100Base-TX, 10Base-Te
- RMII Onboard Clock
- Output Clock
- Onboard MSP430F5529 for easy MDIO Register Access
- LDO and External Power Supply Options
- Status LEDs
- Variable I/O Voltage Range: 1.8-V and 3.3-V
- Bootstraps for Hardware Configuration
- 100BASE-TX Data Transfer Over 150 Meters CAT5 Cable

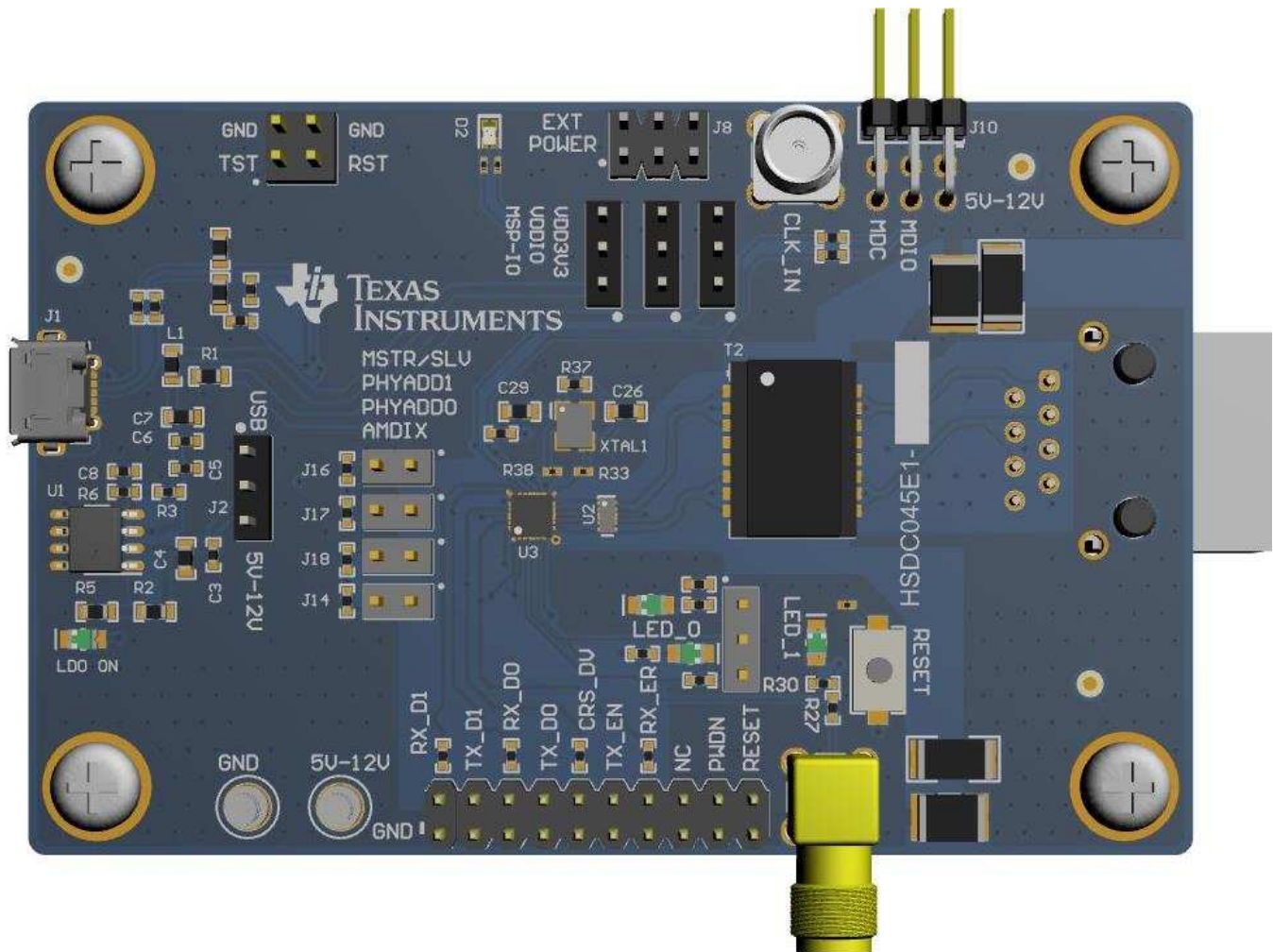

Figure 1. DP83825EVM – Top Side

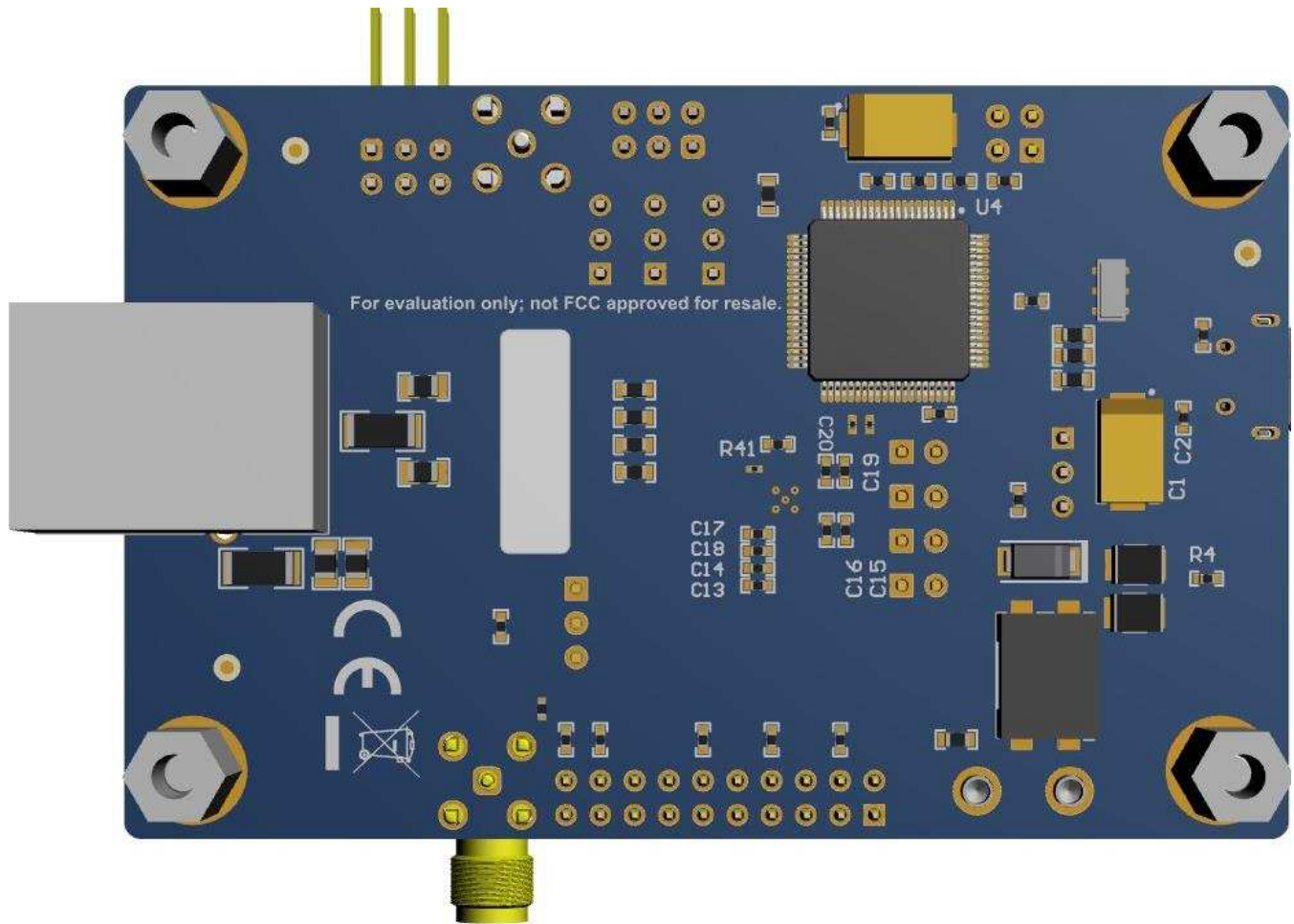

Figure 2. DP83825EVM – Bottom Side

2.2 Operation – Quick Setup

2.2.1 Power Supply

The EVM can be supplied power via multiple options. Single supply operation uses on-board LDOs to generate the voltages required for operating various sections of the EVM (PHY, MSP430 etc). Power can also be supplied externally to individual voltage rails.

2.2.1.1 LDO Supply

The EVM can be used in LDO operation by providing power by using power supply turrets or USB connector. The following jumper connections need to be connected to configure the board for LDO operation.

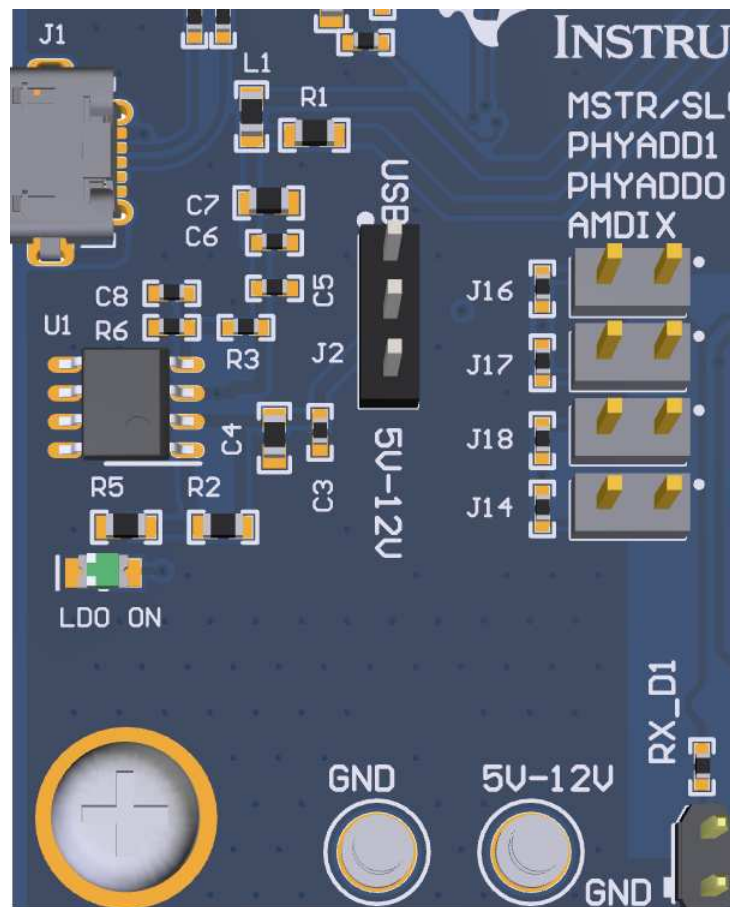

Figure 3. LDO Operation

- For Turret, connect jumper to position 2-3 on J2 connector as shown in [Figure 3](#) and supply power through '5V-12V' and 'GND' turrets.
- For USB power, connect jumper to position 1-2 on J2 connector as shown in [Figure 3](#) and supply power through J1 USB connector.
- On the VDD3V3, VDDIO, and MSP-IO connections ensure that the jumpers are populated on position 1-2 for all three connectors shown in [Figure 4](#).

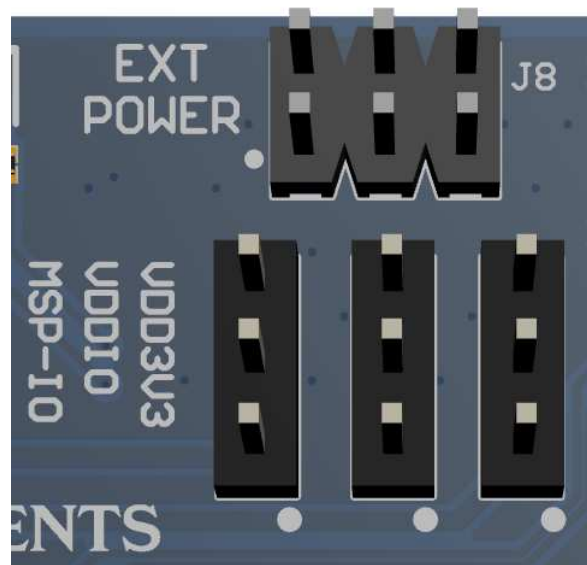

Figure 4. Supply Selection Jumpers - LDO

2.2.1.2 External Supply

DP83825EVM provides the option to power individual voltage rails from external power source giving customers more flexibility with EVM testing. 'VDD3V3', 'VDDIO', and 'MSP-IO' connectors shown above are used to switch individual rails from LDO source to External source. Connect jumper between pin 2-3 to switch from LDO supply to External power source. Then supply power through corresponding pin on J8.

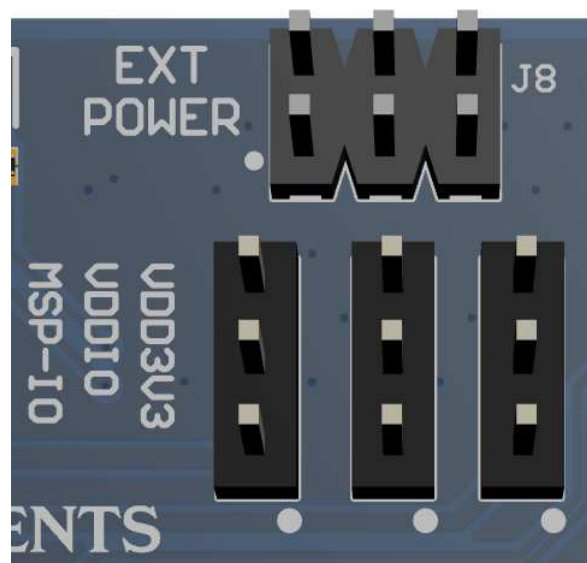

Figure 5. Supply Selection Jumpers - LDO

For example: If VDD3V3 needs to be supplied externally, switch the jumper on VDD3V3 connector from position 1-2 to 2-3. Then supply 3.3V external power through pin 5 on J8.

2.2.2 Software

The on-board MSP430 comes pre-programmed and ready to use. When using this EVM for the first time on a Windows 7 (or above) PC, MSP430 drivers and USB2MDIO software utility will have to be installed. USB2MDIO software can be used for accessing registers.

2.2.2.1 MSP430 Driver

Install the latest MSP430 drive from this website: http://software-dl.ti.com/msp430/msp430_public_sw/mcu/msp430/MSP430_FET_Drivers/latest/index_FDS.html .

2.2.2.2 USB2MDIO Software

Download the software from <http://www.ti.com/tool/usb-2-mdio> .

The webpage also contains User's Guide for installing and using the software. Because MSP430 is on board the EVM, it is not required to purchase a separate MSP430 Launchpad kit and connect to the PHY using wires. The entire EVM can be powered and controlled via USB connector. MSP430 and USB2MDIO utility can be used even when power is not supplied via USB.

Incase the onboard MSP430 cannot be used due to some reason, MDIO and MDC pins are also broken out on J10 connector. Customers can connect a MSP430 launchpad or their own MDIO-MDC utility on J10 to access the PHY registers.

3 Board Setup Details

3.1 Block Diagram

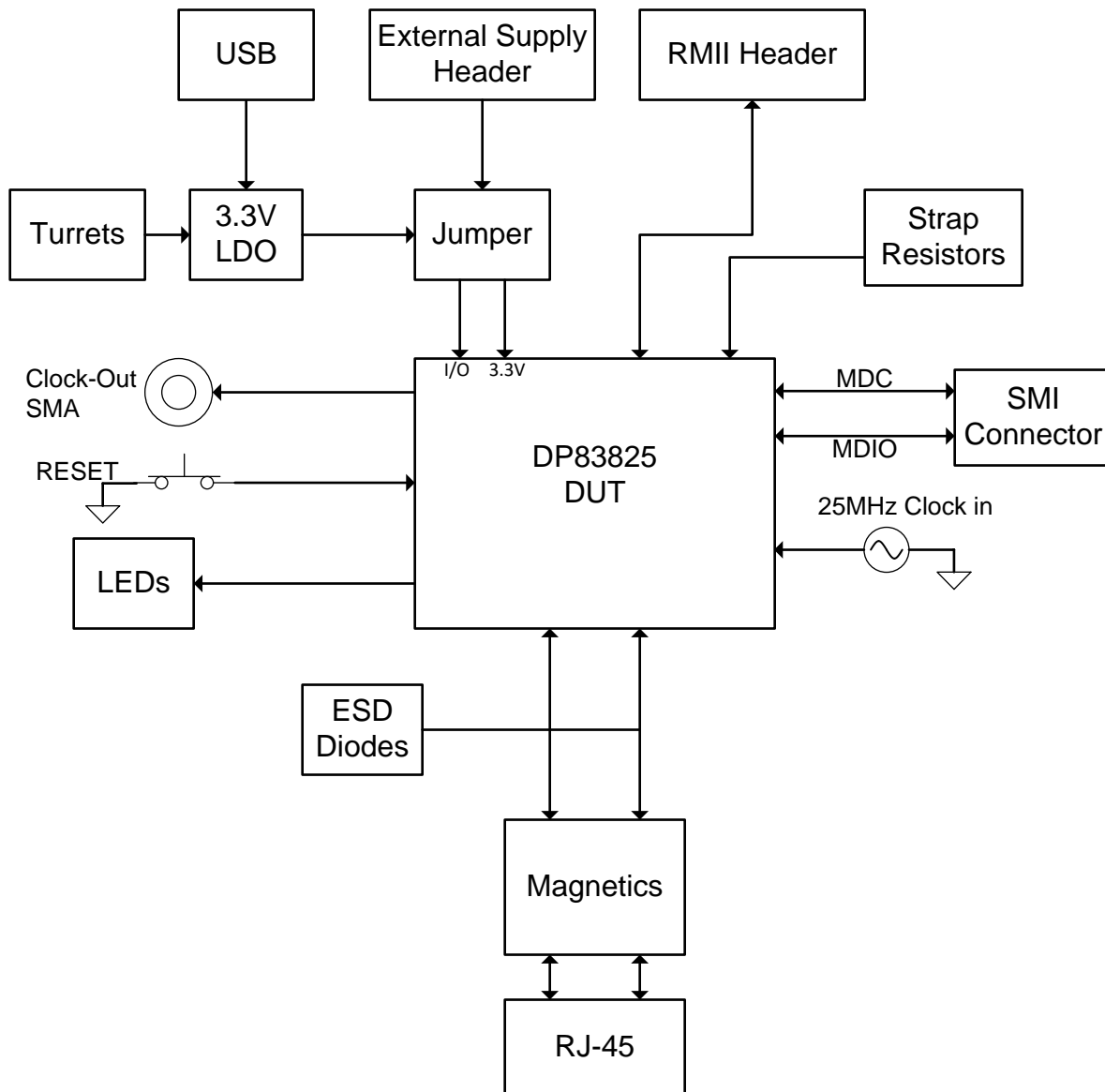

Figure 6. DP83825EVM Block Diagram

3.2 EVM High Level Summary

Table 2. EVM Applications

NO.	DP83825 MODE	APPLICATIONS	HOW TO USE
1	RMII to Copper	Run traffic between RMII and Copper.	Connect to DP83822 EVM or MAC System using Header pins.
		Perform IEEE and UNH compliance testing	Using onboard MSP430 and software.
		Run EMI/EMC Test on EVM	Use internal PRBS and loopback. MSP430 launchpad can be used for register access.
		Measure Power Dissipation	Connect external power supplies.
		External MAC loopback	Connect external MAC to headers and use MAC loopback register settings
		50MHz output clock	Optional Clock out SMA
2	RMII Loopback	Data received by the PHY can be looped back through the RMII interface without needing a MAC.	Use jumpers to connect TXD0->RXD0, TXD1->RXD1, and TXEN->RXDV.
3	Repeater Mode	RMII back to back as range extender.	Two EVMs can be connected back to back using custom header cable.
4	Low Power modes	Demonstrate EEE	Straps to enable EEE.
		Demonstrate Sleep and Power down mode	Use MSP430 launchpad to activate low power mode

4 Configurations Options

4.1 Strap Options

All straps are only two level straps in DP83825. DP83825 contains internal pull down resistors on the strap pins. The EVM takes advantage of this feature and has only pull up resistors on the board. When DP83825 strap pins are using internal pull down the corresponding pin is strapped to '0' and when the strap pin has an external pull up resistor connected, the corresponding pin will be strapped to '1'. J14, J16, J17, J18 are used as pull up strap jumper connectors as shown in the picture below. When any strap pin needs to be strapped to '0' on the EVM, disconnect the corresponding jumper. When a strap pin needs to be strapped to '1', populated the corresponding jumper.

Table 3. Strap Value

STRAP VALUE	'1'	'0'
Resistor Pull Up	2.49 kΩ	Open
Resistor Pull Down	Open	2.49 kΩ (optional)

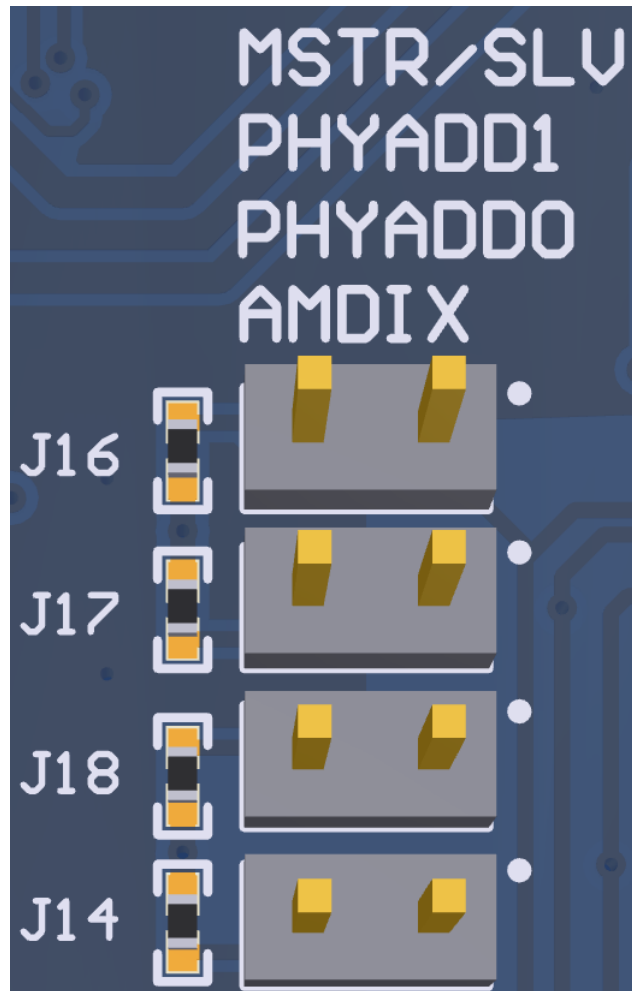

Figure 7. Strap Pins

The LED_0 pin also has a strap. Because LED pins have automatic polarity, separate LEDs are used on the EVM depending on LED_0 pin being strapped high or low. In position 1-2 LED_0 will be pulled low (0) and in position 2-3 LED_0 will be pulled high (1).

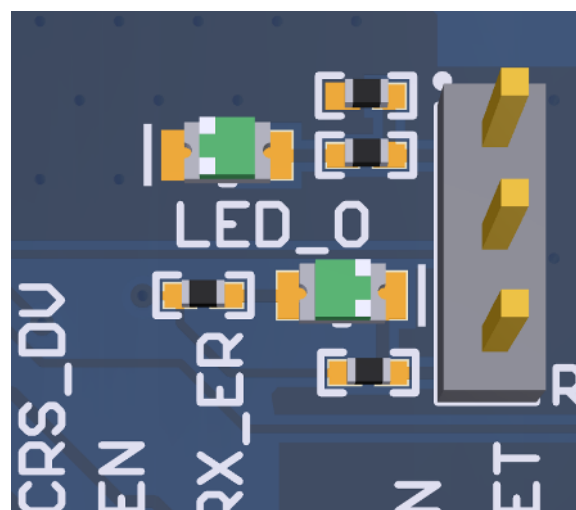

Figure 8. LED_0 Strap

Table 4. Strap Options Table

PIN NAME	STRAP NAME	PIN NO	DEFAULT	VALUE	DESCRIPTION
LED_0	ANEG_DIS	4	0	0	Enable Auto negotiation
				1	Disable Auto negotiation
RX_D1	RMII_MAS	17	0	0	RMII Master Mode
				1	RMII Slave Mode
RX_D0	PHY_AD[0]	18	0	0	PHY_AD[0] = 0
				1	PHY_AD[0] = 1
CRS_DV	PHY_AD[1]	20	0	0	PHY_AD[1] = 0
				1	PHY_AD[1] = 1
RX_ER	AMDIX_DIS	22	0	0	AMDIX Enabled
				1	AMDIX Disabled

5 REACH Compliance

In compliance with the Article 33 provision of the EU REACH regulation we are notifying you that this EVM includes component(s) containing at least one Substance of Very High Concern (SVHC) above 0.1%. These uses from Texas Instruments do not exceed 1 ton per year. The SVHC's are:

Component Manufacturer	Component Part Number	SVHC Substance	SVHC CAS
Murata	CSTCR4M00G15L99-R0	Lead titanium zirconium oxide (Pb(Ti,Zr)O ₃)	12626-81-2

This component is used only in the prototype version of the EVM and will be replaced in the next revision.

IMPORTANT NOTICE AND DISCLAIMER

TI PROVIDES TECHNICAL AND RELIABILITY DATA (INCLUDING DATA SHEETS), DESIGN RESOURCES (INCLUDING REFERENCE DESIGNS), APPLICATION OR OTHER DESIGN ADVICE, WEB TOOLS, SAFETY INFORMATION, AND OTHER RESOURCES "AS IS" AND WITH ALL FAULTS, AND DISCLAIMS ALL WARRANTIES, EXPRESS AND IMPLIED, INCLUDING WITHOUT LIMITATION ANY IMPLIED WARRANTIES OF MERCHANTABILITY, FITNESS FOR A PARTICULAR PURPOSE OR NON-INFRINGEMENT OF THIRD PARTY INTELLECTUAL PROPERTY RIGHTS.

These resources are intended for skilled developers designing with TI products. You are solely responsible for (1) selecting the appropriate TI products for your application, (2) designing, validating and testing your application, and (3) ensuring your application meets applicable standards, and any other safety, security, regulatory or other requirements.

These resources are subject to change without notice. TI grants you permission to use these resources only for development of an application that uses the TI products described in the resource. Other reproduction and display of these resources is prohibited. No license is granted to any other TI intellectual property right or to any third party intellectual property right. TI disclaims responsibility for, and you will fully indemnify TI and its representatives against, any claims, damages, costs, losses, and liabilities arising out of your use of these resources.

TI's products are provided subject to [TI's Terms of Sale](#) or other applicable terms available either on ti.com or provided in conjunction with such TI products. TI's provision of these resources does not expand or otherwise alter TI's applicable warranties or warranty disclaimers for TI products.

TI objects to and rejects any additional or different terms you may have proposed.

Mailing Address: Texas Instruments, Post Office Box 655303, Dallas, Texas 75265
Copyright © 2022, Texas Instruments Incorporated