

PART NUMBER	REV	FIRST USED
680518-1	B	122500-1
680518-2	B	565435-5
680518-3	B	354500-1

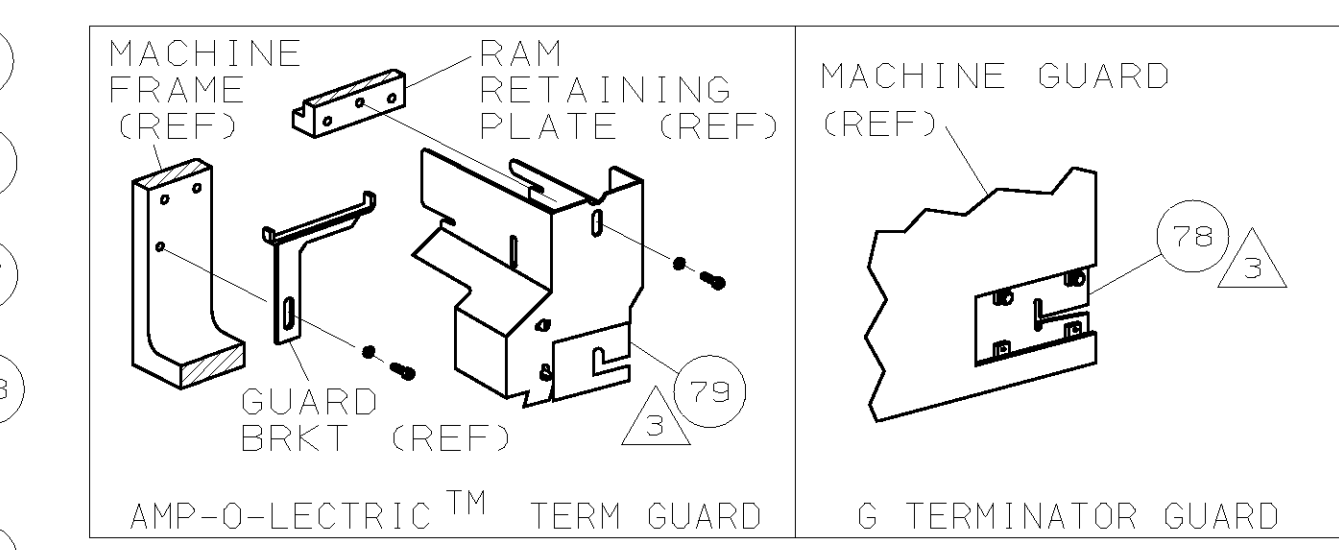
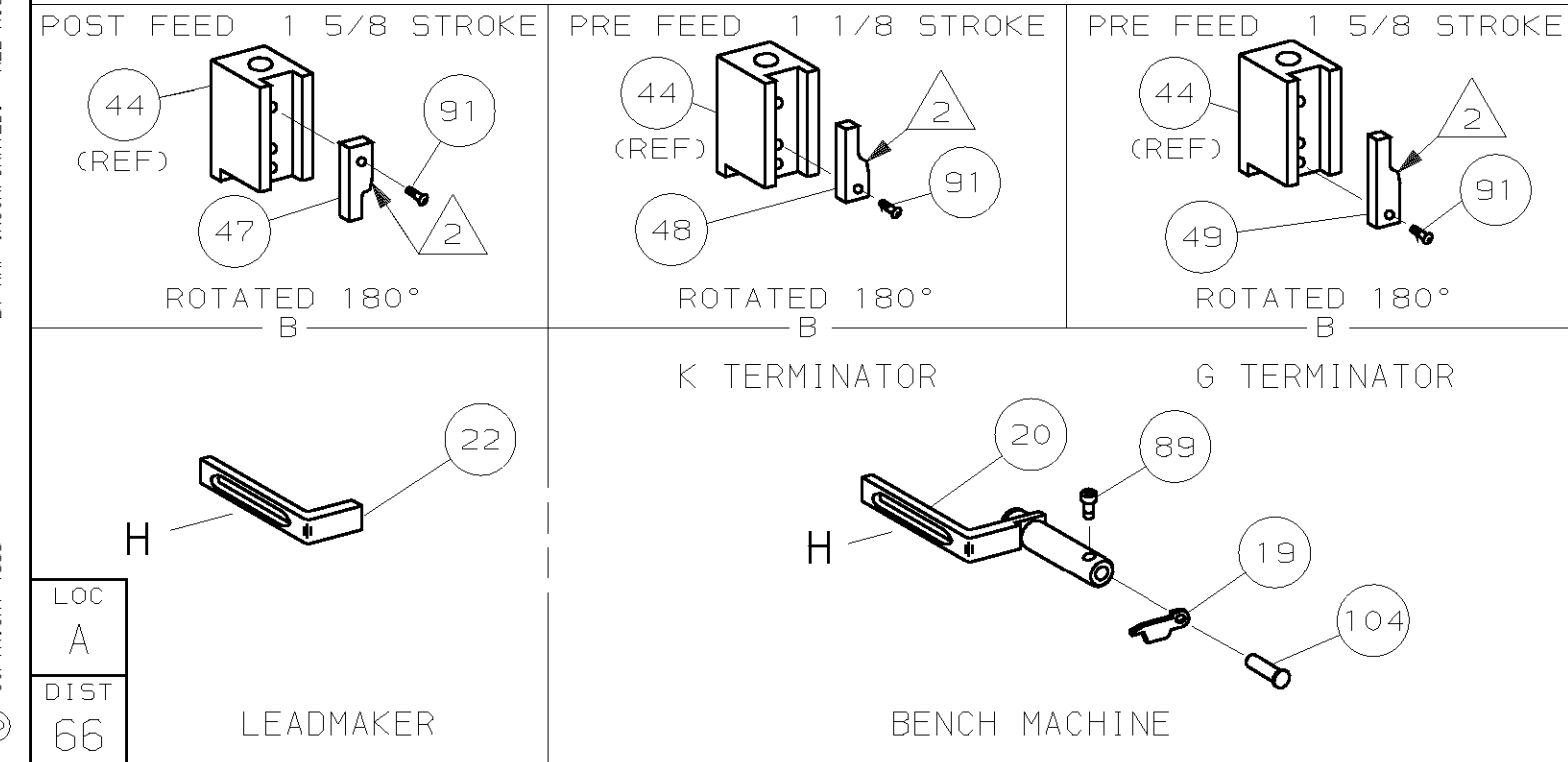
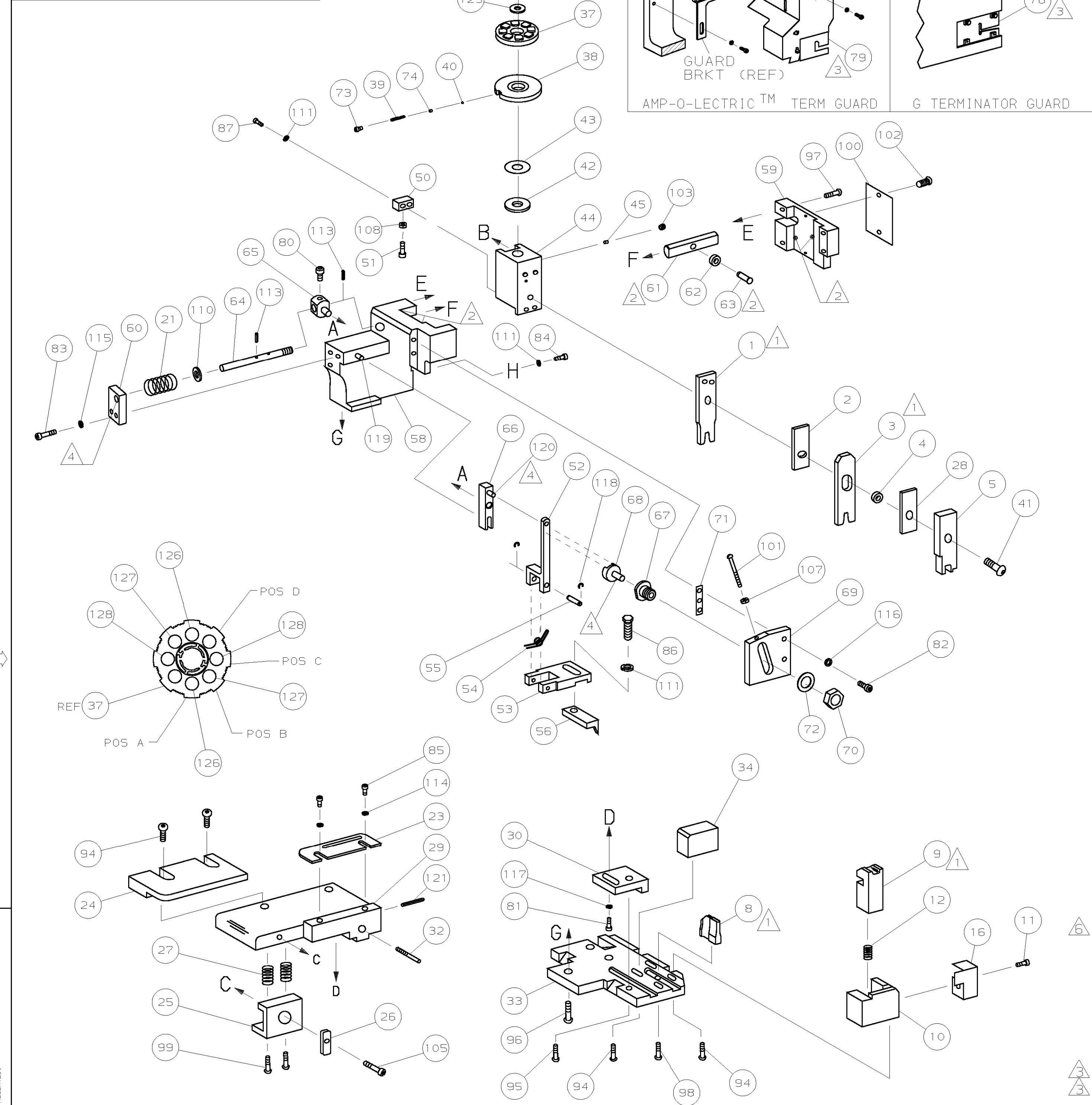

- 1 RECOMMENDED SPARE PARTS.
- 2 GREASE LIGHTLY.
- 3 GUARD MUST BE IN PLACE WHEN OPERATING APPLICATOR IN A BENCH MACHINE.
- 4 LUBRICATE DAILY USING NO. 20 MACHINE OIL.
- 5. ITEMS WITH QTY OF REF SPECIFIED (EXCEPT ITEMS 78 AND 79) ARE USED ON ITEM 46.
- 6 CUT TO LENGTH AT ASSY

TERMINAL NAME: TERMINAL, TAB		CRIMPING DATA	
PAD LTR	CRIMP HEIGHT	WIRE SIZE	
A	.059 ±.002 [1.50 ±0.05mm]	18	
B	.057 ±.002 [1.45 ±0.05mm]	18AU	
C	.053 ±.002 [1.35 ±0.05mm]	20 or 20AU	
D	NOT	USED	
CRIMP	SIZE	TYPE	RANGE
WIRE	.096 [2.44mm]	F	20-18
INSUL	.110 [2.79mm]	0	φ.076-.084

QTY	REF	REF	REF	U/M	DWG SIZE	PART NO	DESCRIPTION	ITEM NO
2	2	2	-	C		3-354779-4	PIN, WIRE DISC (.3160)C	129
2	2	2	-	C		2-354779-6	PIN, WIRE DISC (.3120)B	128
2	2	2	-	C		1-354779-7	PIN, WIRE DISC (.3075)A	126
1	1	1	-	A		986950-1	WASHER, FLAT PRECISION	125
1	1	1	-	A		217238-1	GENERAL INSTRUCTION PACKAGE	124
1	1	1	-	-		4088040	SF APPL INST 408-8040	123
1	1	1	-	A		4-21028-0	PIN,SLT SPR(φ.093x.75)ST GDE PL	122
REF	REF	REF	-	A		1-21030-1	PIN,DOWEL(φ.187x.50)LEVER	120
REF	REF	REF	-	A		1-21030-6	PIN,DOWEL(φ.187x.1.25)HOUSING	119
REF	REF	REF	-	A		21045-3	RING,RET "C"(φ.187)FD FING PIN	118
1	1	1	-	A		21024-5	WASHER, LOCK(#10)ADJ BLOCK	117
REF	REF	REF	-	A		21024-5	WASHER,LOCK(#10)ADJ PLATE	116
REF	REF	REF	-	A		21024-5	WASHER,LOCK(#10)FEED GDE ROD	115
2	2	2	-	A		21024-2	WASHER,LOCK(#4)FRONT STP GUIDE	114
REF	REF	REF	-	A		5-21028-1	PIN,SLT SPR(φ.125x.50)ADJ ROD	113
4	4	4	-	A		21024-4	WASHER,LOCK(#8)STRIPPER	112
REF	REF	REF	-	A		21899-4	WASHER,FLAT(φ5/16)SCREW ADJ	110
1	1	1	-	A		21018-5	NUT,HEX(NO.6)HOLDDOWN	108
REF	REF	REF	-	A		21018-5	NUT,HEX(6-32)FEED ADJ	107
1	1	1	-	A		22353-8	SCR,5HLD(φ.187x.25)DRAG LEVER	105
1	1	1	-	A		992031-1	PIN, CLEVIS	104
1	1	1	-	A		21009-2	SCR,5KT SET(1/4-20x.25 LW)RAM	103
2	2	2	-	A		21017-2	SCR,DRIVE(#2x.19)ID PLATE	102
REF	REF	REF	-	A		6-23715-5	SCR,PAN HD(6-32x1.50)FEED ADJ	101
1	1	1	-	B		461264-1	PLATE, IDENTIFICATION	100
2	2	2	-	A		3-21002-0	SCR,BHC(10-32x.88)DRAG	99
1	1	1	-	A		22733-8	SCR,BHC(8-32x.38 LW)ANVIL	98
REF	REF	REF	-	A		2-21002-9	SCR,BHC(10-32x.75)CAP	97
REF	REF	REF	-	A		2-22733-8	SCR,BHC(1/4-20x.62)HOUSING	96
REF	REF	REF	-	A		2-21002-7	SCR,BHC(10-32x.50)5G ADJ BLOCK	95
6	6	6	-	A		2-21002-2	SCR,BHC(8-32x.50)TERM H DWN	94
1	1	1	-	A		1-21002-7	SCR,BHC(6-32x.38)CAM	91
1	1	-	-	A		7-21000-9	SCR,5HC(4-40x.19)STRIPPER	89
2	2	2	-	A		2-21000-7	SCR,5HC(8-32x.48)DEP-HOLD	87
1	1	1	-	A		2-22603-0	SCR,HEX HD(8-32x.31)FEED FINGER	86
2	2	2	-	A		1-21000-3	SCR,5HC(4-40x.25)F ST GUIDE	85
1	1	1	-	A		2-21000-7	SCR,5HC(8-32x.50)STRIPPER	84
REF	REF	REF	-	A		3-21000-7	SCR,5HC(10-32x.75)FEED ROD GD	83
REF	REF	REF	-	A		3-21000-6	SCR,5HC(10-32x.62)FD ADJ BLK	82
1	1	1	-	A		3-21000-4	SCR,5HC(10-32x.38)5G ADJ BL	81
REF	REF	REF	-	A		3-21000-4	SCR,5HC(10-32x.38)PIVOT BLK	80
-	REF	-	-	B		455749-1	GUARD, WINDOW	79
REF	-	-	-	B		679532-1	INSERT, GUARD	78
1	1	1	-	A		690603-1	SPRING, ASSIST	74
1	1	1	-	A		23030-1	SCR,5HC(6-32x.25 SL)INS DISC	73
REF	REF	REF	-	A		458109-1	WASHER, SPECIAL	72
REF	REF	REF	-	A		690517-1	SPACER	71

QTY	REF	REF	REF	U/M	DWG SIZE	PART NO	DESCRIPTION	ITEM NO
-1							LEADMAKER	
-2							BENCH MODEL K	
-3							BENCH MODEL G	
REF	REF	REF	-	B		22594-8	NUT,HEX(1/2-20)	70
REF	REF	REF	-	B		240628-1	PLATE, ADJUSTMENT	69
REF	REF	REF	-	B		240626-1	SHAFT, PIVOT	68
REF	REF	REF	-	B		240633-1	BUSHING	67
REF	REF	REF	-	A		455680-1	LEVER, INTERMEDIATE	66
REF	REF	REF	-	B		240629-1	BLOCK, PIVOT	65
REF	REF	REF	-	A		240632-2	SCREW, ADJ FEED ROD	64
REF	REF	REF	-	B		240659-3	PIN, CAM ROLLER	63
REF	REF	REF	-	B		240658-1	ROLLER, CAM	62
REF	REF	REF	-	B		454398-2	ROD, FEED	61
REF	REF	REF	-	A		454178-1	GUIDE, FEED ROD	60
REF	REF	REF	-	C		454220-1	CAP, RAM	59
REF	REF	REF	-	D		454485-1	HOUSING	58
1	1	1	-	B		694433-4	PAWL, FEED	56
REF	REF	REF	-	B		240624-1	PIN, FEED FINGER	55
REF	REF	REF	-	B		691499-1	SPRING, FEED FINGER	54
REF	REF	REF	-	B		690541-1	HOLDER, FEED FINGER	53
REF	REF	REF	-	A		455679-2	LEVER, TERMINAL FEED ARM	52
1	1	1	-	A		81124-2	BUMPER, HOLDDOWN	51
1	1	1	-	A		690753-1	SPACER, TONKER	50
1	-	-	-	B		690602-6	CAM, PRE-FEED 1 5/8 ST	49
-	1	-	-	B		690602-5	CAM, PRE-FEED 1 1/8 ST	48
-	-	1	-	B		690501-4	CAM, POST-FEED 1 5/8 ST	47
1	1	1	-	B		459456-2	APPLICATOR, BASIC (SUBASSY)	46
1	1	1	-	A		690191-1	PLUG, NYLON	45
1	1	1	-	C		455673-1	RAM	44
1	1	1	-	A		690125-1	WASHER, LAMINATED	43
1	1	1	-	A		690124-1	WASHER, RAM	42
1	1	1	-	A		7-21002-9	BOLT, CRIMPER(5/16x1.00)	41
1	1	1	-	A		23241-6	BALL, STEEL	40
1	1	1	-	A		690170-1	SPRING, COMPRESSION	39
1	1	1	-	C		690142-1	DISC, INSULATION	38
1	1	1	-	D		354777-1	WIRE DISC, PLASTIC	37
1	1	1	-	A		22480-5	WASHER, SPRING	36
1	1	1	-	B		690212-1	POST, RAM	35
1	1	1	-	B		690786-1	SUPPORT, TERMINAL	34
REF	REF	REF	-	D		455675-1	PLATE, BASE	33
1	1	1	-	A		690432-3	SCREW, ADJUSTMENT	32
REF	REF	REF	-	B		455689-1	BLOCK, STRIP GUIDE ADJ	30
1	1	1	-	C		458144-1	PLATE, STRIP GUIDE	29
1	1	1	-	C		1-455888-0	SPACER, FRONT SHEAR DEP	28
2	2	2	-	A		1-22284-0	SPRING, DRAG	27
1	1	1	-	B		240793-1	LEVER, DRAG RELEASE	26
1	1	1	-	B		240792-1	DRAG, TERMINAL	25
1	1	1	-	D		1-90765-8	GUIDE, STRIP (REAR)	24
1	1	1	-	A		690438-1	GUIDE, STRIP (FRONT)	23
-	-	1	-	B		690472-2	STRIPPER	22
REF	REF	REF	-	A		4-22284-9	SPRING, FEED RETURN	21
1	1	-	-	A		679218-1	STRIPPER WIRE STOP ASSY	20
1	1	-	-	B		458949-1	STRIPPER	19
1	1	1	-	B		318563-1	GUARD, CHIP, FRONT	16
1	1	1	-	C		2-455889-0	DEPRESSOR, SHEAR (FRONT)	5
1	1	1	-	B		1-238011-0	SPACER, BLOCK CRIMPER	4
1	1	1	-	C		6-683454-4	CRIMPER, INSULATION	3
1	1	1	-	C		1-455888-4	SPACER, CRIMPER	2
1	1	1	-	C		3-568176-3	CRIMPER, WIRE	1