

# Current Mode PWM Control Circuit with 50% Max Duty Cycle

## Description

The CS3845B provides all the necessary features to implement off-line fixed frequency current-mode control with a minimum number of external components.

The CS3845B incorporates a precision temperature-controlled oscillator to minimize variations in frequency. An internal toggle flip-flop, which blanks the output off every other clock cycle, ensures that the duty-cycle never

exceeds 50%. The undervoltage lock-out feature ensures that  $V_{REF}$  is stabilized within specification before the output stage is enabled. **The CS3845B has been optimized for lower start up current (500 $\mu$ A max).**

Other features include 1% trimmed band gap reference, pulse-by-pulse current limiting, and a high-current totem pole output for driving capacitive loads.

## Features

- Optimized for Off-line Use
- Temperature Compensated Oscillator
- 50% Maximum Duty-cycle Clamp
- Low Start-up Current (500 $\mu$ A max)
- Pulse-by-pulse Current Limiting
- Undervoltage Active Pull Down
- Double Pulse Suppression
- 1% Trimmed Bandgap Reference
- High Current Totem Pole Output

## Absolute Maximum Ratings

Supply Voltage ( $I_{CC} < 30\text{mA}$ )	Self Limiting
Supply Voltage (Low Impedance Source)	30V
Output Current	$\pm 1\text{A}$
Output Energy (Capacitive Load)	5 $\mu\text{J}$
Analog Inputs ( $V_{FB}$ , $V_{SENSE}$ )	-0.3V to 5.5V
Error Amp Output Sink Current	10mA
Lead Temperature Soldering	
Wave Solder (through hole styles only)	10 sec. max, 260°C peak
Reflow (SMD styles only)	60 sec. max above 183°C, 230°C peak

## Block Diagram

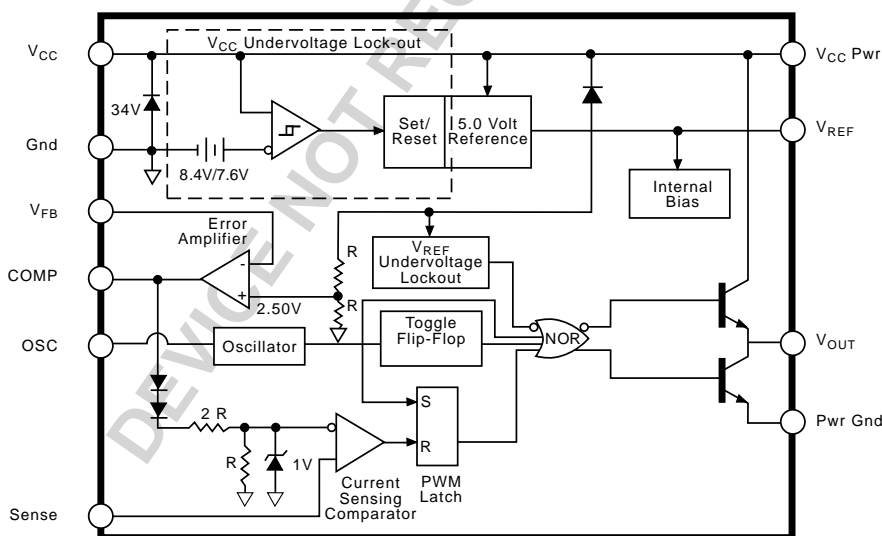

## Package Options

### 8 Lead PDIP & SO

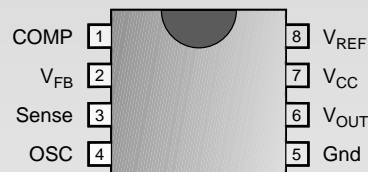

### 14 Lead SO Narrow

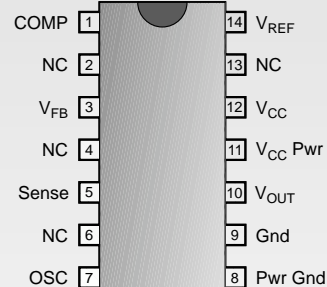

PARAMETER	TEST CONDITIONS	MIN	TYP	MAX	UNITS
<b>Reference Section</b>					
Output Voltage	$T_J = 25^\circ\text{C}$ , $I_{REF} = 1\text{mA}$	4.90	5.00	5.10	V
Line Regulation	$12 \leq V_{CC} \leq 25\text{V}$		6	20	mV
Load Regulation	$1 \leq I_{REF} \leq 20\text{mA}$		6	25	mV
Temperature Stability	(Note 1)		0.2	0.4	mV/ $^\circ\text{C}$
Total Output Variation	Line, Load, Temp. (Note 1)	4.82		5.18	V
Output Noise Voltage	$10\text{Hz} \leq f \leq 10\text{kHz}$ , $T_J = 25^\circ\text{C}$ (Note 1)		50		$\mu\text{V}$
Long Term Stability	$T_A = 125^\circ\text{C}$ , 1000 Hrs. (Note 1)		5	25	mV
Output Short Circuit	$T_A = 25^\circ\text{C}$	-30	-100	-180	mA
<b>Oscillator Section</b>					
Initial Accuracy	Sawtooth Mode, $T_J = 25^\circ\text{C}$	47	52	57	kHz
Voltage Stability	$12 \leq V_{CC} \leq 25\text{V}$		0.2	1.0	%
Temperature Stability	Sawtooth Mode $T_{MIN} \leq T_A \leq T_{MAX}$ (Note 1)		5		%
Amplitude	$V_{OSC}$ (peak to peak)(Note 1)		1.7		V
Discharge	$T_J = 25^\circ\text{C}$ ; (Note 1)	7.5	8.3	9.3	mA
	$T_{MIN} \leq T_A \leq T_{MAX}$ (Note 1)	7.2		9.5	mA
<b>Error Amp Section</b>					
Input Voltage	$V_{COMP} = 2.5\text{V}$	2.42	2.50	2.58	V
Input Bias Current	$V_{FB} = 0\text{V}$		-0.3	-2.0	$\mu\text{A}$
AVOL	$2 \leq V_{OUT} \leq 4\text{V}$	65	90		dB
Unity Gain Bandwidth	(Note 1)	0.7	1.0		MHz
PSRR	$12 \leq V_{CC} \leq 25\text{V}$	60	70		dB
Output Sink Current	$V_{FB} = 2.7\text{V}$ , $V_{COMP} = 1.1\text{V}$	2	6		mA
Output Source Current	$V_{FB} = 2.3\text{V}$ , $V_{COMP} = 5\text{V}$	-0.5	-0.8		mA
$V_{OUT}$ HIGH	$V_{FB} = 2.3\text{V}$ , $R_L$ 15k $\Omega$ to Gnd	5	6		V
$V_{OUT}$ LOW	$V_{FB} = 2.7\text{V}$ , $R_L = 15\text{k}\Omega$ to $V_{REF}$		0.7	1.1	V
<b>Current Sense Section</b>					
Gain	(Notes 2&3)	2.85	3.00	3.15	V/V
Maximum Input Signal	$V_{COMP} = 5\text{V}$ (Note 2)	0.9	1.0	1.1	V
PSRR	$12 \leq V_{CC} \leq 25\text{V}$ (Note 2)		70		dB
Input Bias Current	$V_{Sense} = 0\text{V}$		-2	-10	$\mu\text{A}$
Delay to Output	$T_J = 25^\circ\text{C}$ (Note 1)		150	300	ns
<b>Output Section</b>					
Output Low Level	$I_{SINK} = 20\text{mA}$		0.1	0.4	V
	$I_{SINK} = 200\text{mA}$		1.5	2.2	V
Output High Level	$I_{SOURCE} = 20\text{mA}$	13.0	13.5		V
	$I_{SOURCE} = 200\text{mA}$	12.0	13.5		V
Rise Time	$T_J = 25^\circ\text{C}$ , $C_L = 1\text{nF}$ (Note 1)		50	150	ns
Fall Time	$T_J = 25^\circ\text{C}$ , $C_L = 1\text{nF}$ (Note 1)		50	150	ns

## Electrical Characteristics: continued

PARAMETER	TEST CONDITIONS	MIN	TYP	MAX	UNITS
<b>■ Total Standby Current</b>					
Start-Up Current			300	500	μA
Operating Supply Current	$V_{FB} = V_{Sense} = 0V$ $R_T = 10k\Omega$ , $C_T = 3.3nF$		11	17	mA
$V_{CC}$ Zener Voltage	$I_{CC}=25mA$		34		V
<b>■ PWM Section</b>					
Maximum Duty Cycle		46	48	50	%
Minimum Duty Cycle				0	%
<b>■ Under-Voltage Lockout Section</b>					
Start Threshold		7.8	8.4	9.0	V
Min. Operating Voltage	After Turn On	7.0	7.6	8.2	V

- Notes:**
1. These parameters, although guaranteed, are not 100% tested in production.
  2. Parameter measured at trip point of latch with  $V_{FB}=0$

3. Gain defined as:  $A = \frac{\Delta V_{COMP}}{\Delta V_{Sense}}$ ;  $0 \leq V_{Sense} \leq 0.8V$ .

## Package Pin Description

PACKAGE PIN #		PIN SYMBOL	FUNCTION
8L PDIP & SO	14L SO		
1	1	COMP	Error amp output, used to compensate error amplifier
2	3	$V_{FB}$	Error amp inverting input
3	5	Sense	Noninverting input in Current Sense Comparator
4	7	OSC	Oscillator timing network with Capacitor to Gnd, resistor to $V_{REF}$
5	9	Gnd	Ground
6	10	$V_{OUT}$	Output drive pin
7	12	$V_{CC}$	Positive power supply
8	14	$V_{REF}$	Output of 5V internal reference
	8	Pwr Gnd	Output driver Gnd
	11	$V_{CC}$ Pwr	Output driver positive supply
	2, 4, 6, 13	NC	No Connection

**Test Circuit**

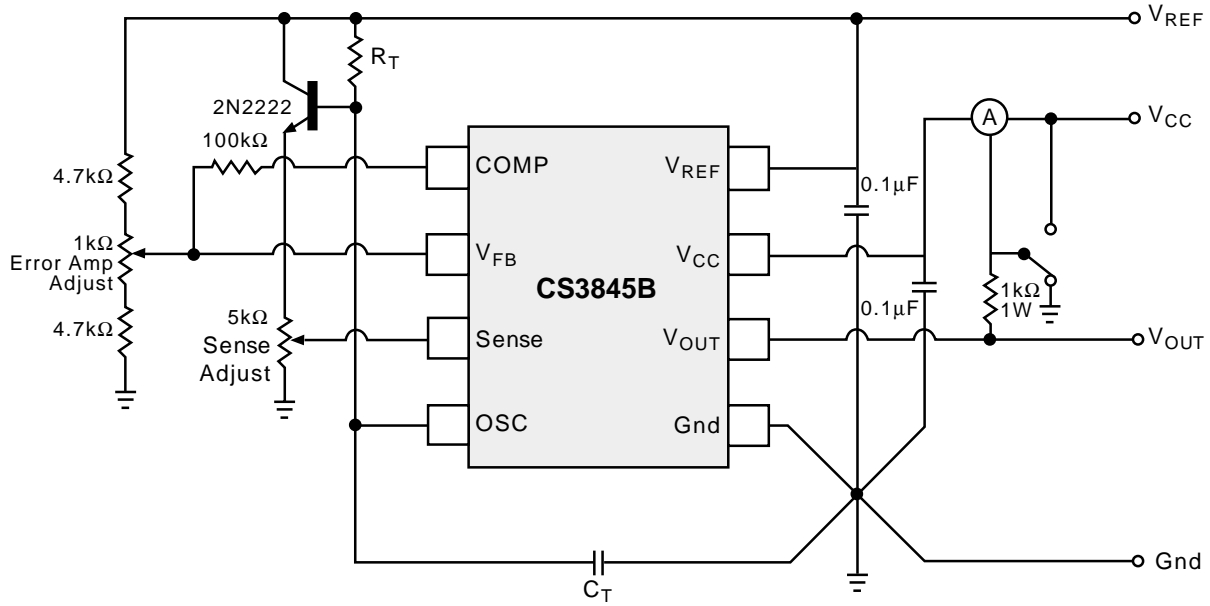

**Circuit Description**

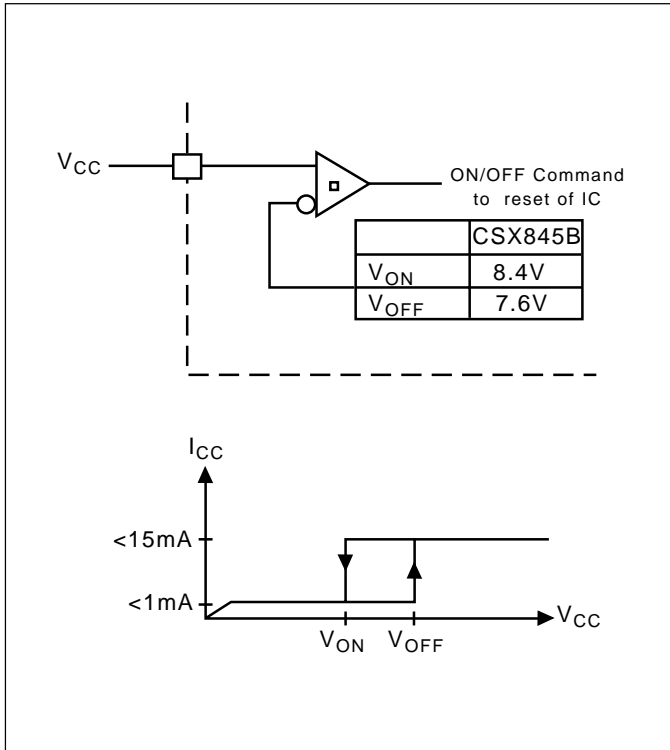

Figure 1: Startup voltage for CS3845B.

**Undervoltage Lockout**

During Undervoltage Lockout (Figure 1), the output driver is biased to sink minor amounts of current. The output should be shunted to ground with a resistor to prevent activating the power switch with extraneous leakage currents.

**PWM Waveform**

To generate the PWM waveform, the control voltage from the error amplifier is compared to a current sense signal which represents the peak output inductor current (Figure 2). An increase in V<sub>CC</sub> causes the inductor current slope to increase, thus reducing the duty cycle. This is an inherent feed-forward characteristic of current mode control, since the control voltage does not have to change during changes of input supply voltage.

When the power supply sees a sudden large output current increase, the control voltage will increase allowing the duty cycle to momentarily increase. Since the duty cycle tends to exceed the maximum allowed to prevent transformer saturation in some power supplies, the internal oscillator waveform provides the maximum duty cycle clamp as programmed by the selection of OSC components.

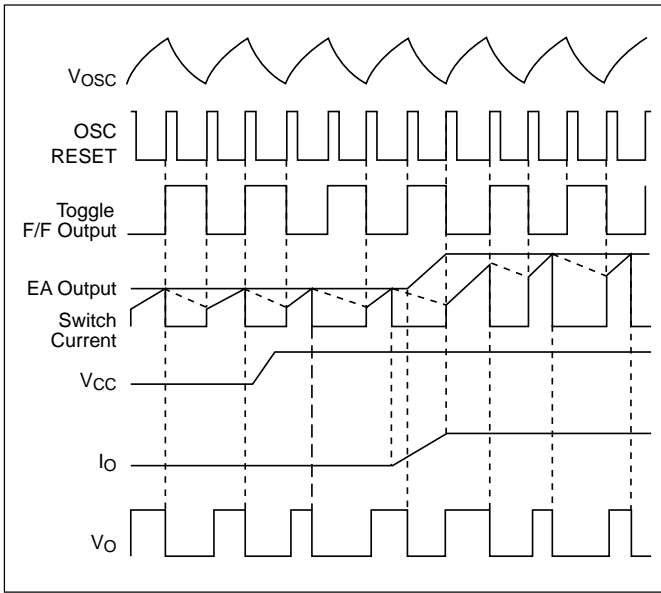

Figure 2: Timing Diagram

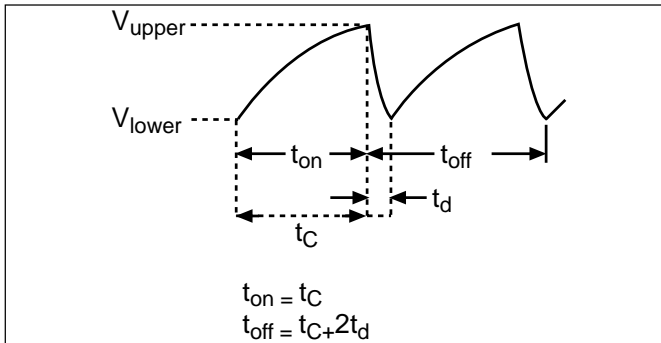

Figure 3: Timing Parameters.

### Setting the Oscillator

The parameters  $T_c$  and  $T_d$  can be determined as follows:

$$t_c = R_T C_T \ln \left( \frac{V_{REF} - V_{lower}}{V_{REF} - V_{upper}} \right)$$

$$t_d = R_T C_T \ln \left( \frac{V_{REF} - I_d R_T - V_{lower}}{V_{REF} - I_d R_T - V_{upper}} \right)$$

Substituting in typical values for the parameters in the above formulas:

$$V_{REF} = 5.0V, V_{upper} = 2.7V, V_{lower} = 1.0V, I_d = 8.3mA,$$

then

$$t_c \approx 0.5534 R_T C_T$$

$$t_d = R_T C_T \ln \left( \frac{2.3 - 0.0083 R_T}{4.0 - 0.0083 R_T} \right)$$

For better accuracy  $R_T$  should be  $\geq 10k\Omega$ .

### Grounding

High peak currents associated with capacitive loads necessitate careful grounding techniques. Timing and bypass capacitors should be connected close to Gnd in a single point ground.

The transistor and  $5k\Omega$  potentiometer are used to sample the oscillator waveform and apply an adjustable ramp to Sense.

## Package Specification

## PACKAGE DIMENSIONS IN mm (INCHES)

Lead Count	D			
	Metric		English	
	Max	Min	Max	Min
8 Lead PDIP	10.16	9.02	.400	.355
8 Lead SO Narrow	5.00	4.80	.197	.189
14 Lead SO Narrow	8.75	8.55	.344	.337

## PACKAGE THERMAL DATA

Thermal Data		8 L PDIP	8L SO	14 L SO	
$R_{QJC}$	typ	52	45	30	°C/W
$R_{QJA}$	typ	100	165	125	°C/W

## PDIP: 300 mil wide

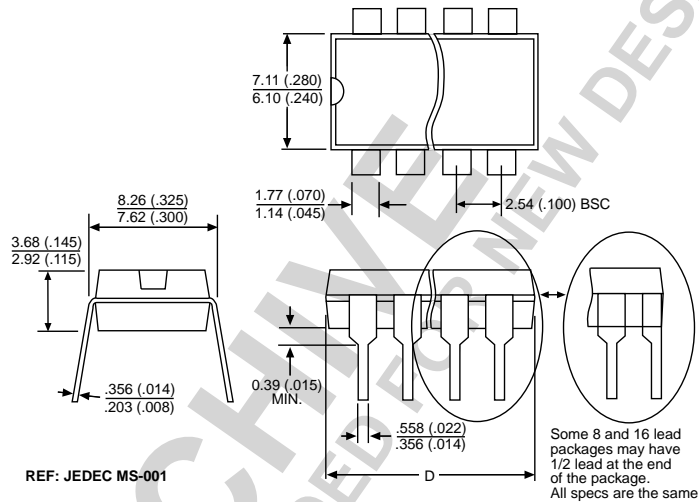

## SO Narrow; 150 mil wide

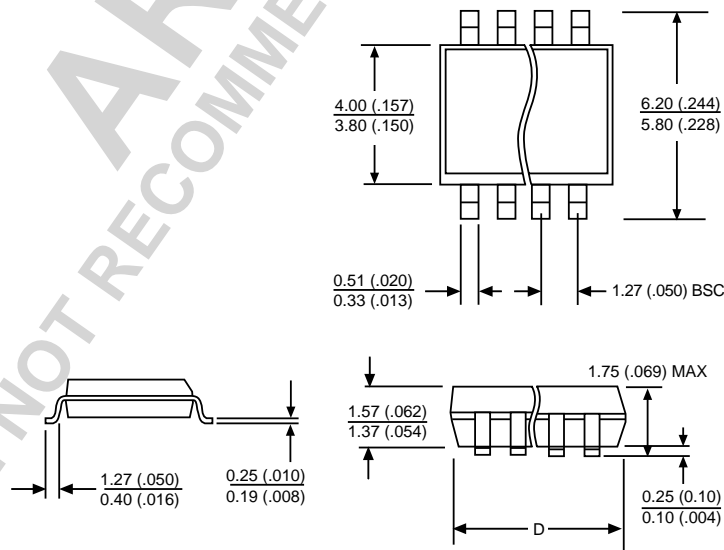

## Ordering Information

Part Number	Description
CS3845BGN8	8L PDIP
CS3845BGD8	8L SO
CS3845BGDR8	8L SO (tape & reel)
CS3845BGD14	14L SO
CS3845BGDR14	14L SO (tape & reel)

ON Semiconductor and the ON Logo are trademarks of Semiconductor Components Industries, LLC (SCILLC). ON Semiconductor reserves the right to make changes without further notice to any products herein. For additional information and the latest available information, please contact your local ON Semiconductor representative.



