

THIS IS A C.A.D. GENERATED DRAWING  
DO NOT MAKE MANUAL REVISIONS TO MASTER.

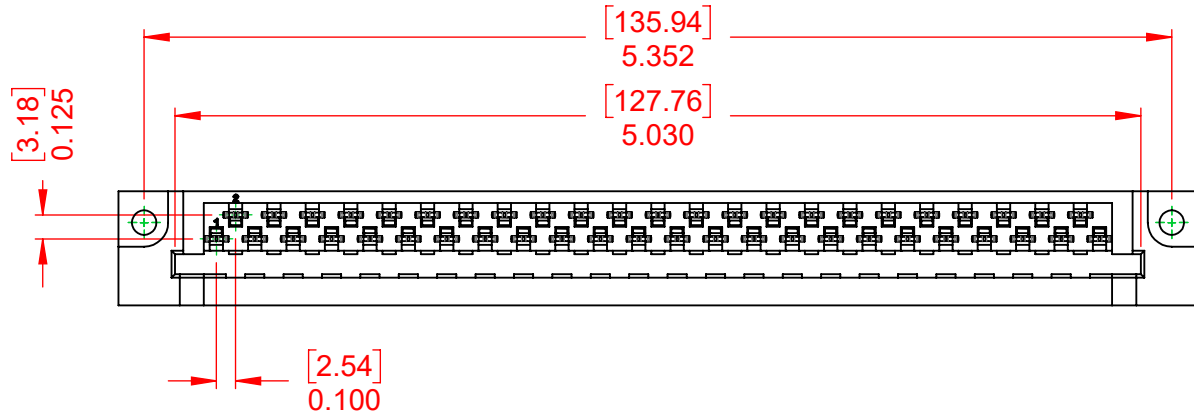

ISSUE NUMBER	
ORIGINAL	①

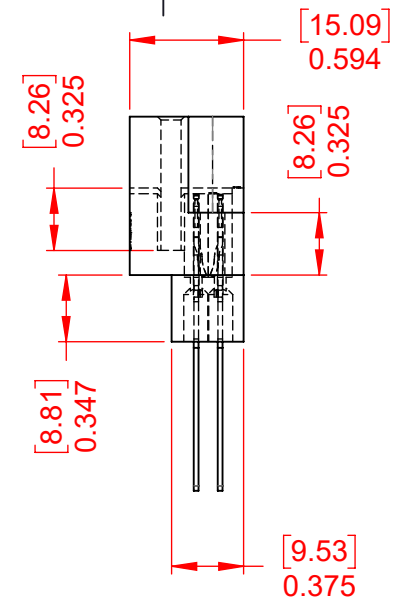
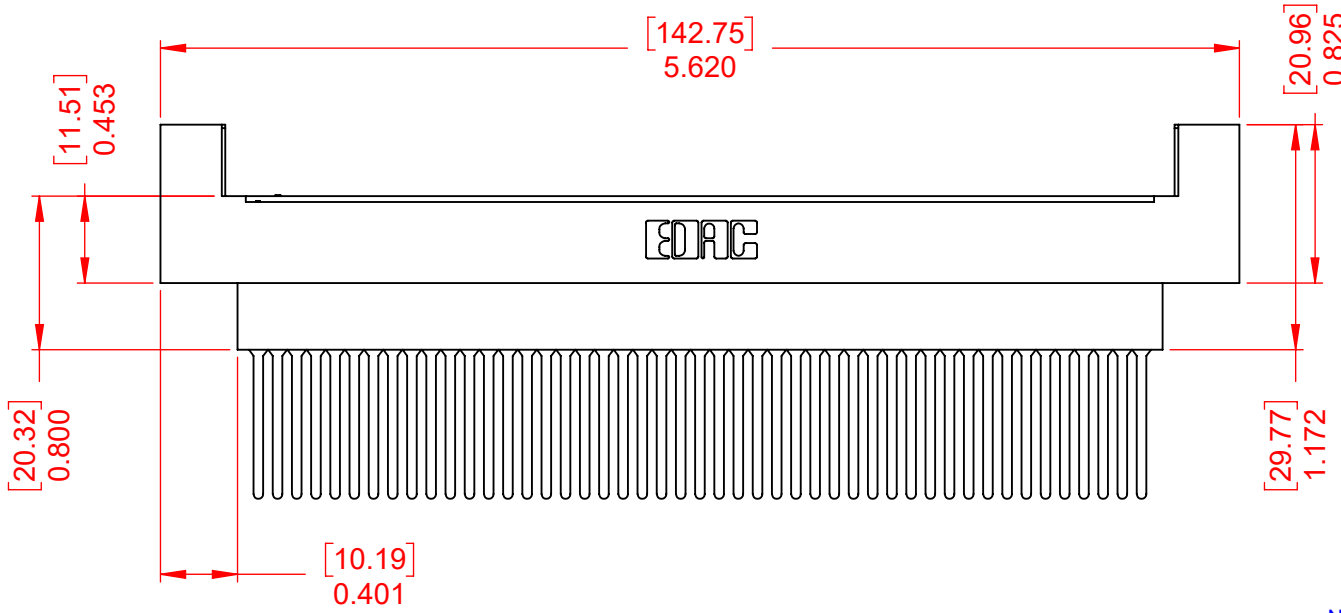

**NOTES:**

- MATERIAL:**  
**HOUSING:** DIALLYL PTHYHALATE, UL94V-0  
**CONTACT MATERIAL:** COPPER ALLOY  
**CONTACT PLATING:** GOLD PLATING OVER NICKEL  
**INSERTION FORCE:** 6 TO 16 Oz (0.56 TO 4.45N) PER CONTACT  
**WITHDRAWAL FORCE:** 6 TO 16 Oz (0.56 TO 4.45N) PER CONTACT
- OPERATING TEMPERATURE:** -65°C ~ 125°C
- CURRENT RATING:** 10A PER CONTACT  
**CONTACT RESISTANCE:** 10mΩ MAX.  
**INSULATOR RESISTANCE:** 5000MΩ min.  
**DIELECTRIC WITHSTANDING VOLTAGE:** 2000V AC rms AT SEA LEVEL
- CONTACT TYPE:**  
 542-Wire Wrap .050x.025(1.27x0.61) - Tail LG.=.790(20.07)



THIS SERIES FULLY CONFORMS TO THE EUROPEAN UNION DIRECTIVES 2011/65/EU FOR RoHS COMPLIANCY.

**EDAC** INC  
 TORONTO, ONTARIO  
 CANADA  
 YOUR CONNECTION TO QUALITY & SERVICE

THESE DRAWINGS AND SPECIFICATIONS ARE THE PROPERTY OF EDAC INC., AND SHALL NOT BE REPRODUCED, OR COPIED OR USED AS THE BASIS FOR THE MANUFACTURE OR SALE OF APPARATUS WITHOUT WRITTEN PERMISSION.

<b>415 &amp; 438 SERIES CARD EDGE</b>		SW REFERENCE NO.: 415 ASSEMBLY	
		DRAWN: W.T	DATE: AUG. 01/2018
		CHECKED:	DATE:
		SCALE: 1:1	SHEET 1 OF 1
DRAWING NUMBER: 415-047-542-222			ISSUE 1
PART NUMBER: 415-047-542-222			