

HEX PRECISION LIMITER

- HIGH PERFORMANCE CLAMPING AT GROUND AND POSITIVE REFERENCE VOLTAGE
- FAST ACTIVE CLAMPING
- OPERATING RANGE 4.75 - 5.25 V
- SINGLE VOLTAGE FOR SUPPLY AND POSITIVE REFERENCE
- LOW QUIESCENT CURRENT
- LOW INPUT LEAKAGE CURRENT

DESCRIPTION

The L9700 is a monolithic circuit which is suited for input protection and voltage clamping purpose.

The limiting function is referred to ground and the positive supply voltage.

One single element contains six independent channels.

Very fast speed is achieved by internal feedback and the application of a new vertical PNP-transistor with isolated collector.

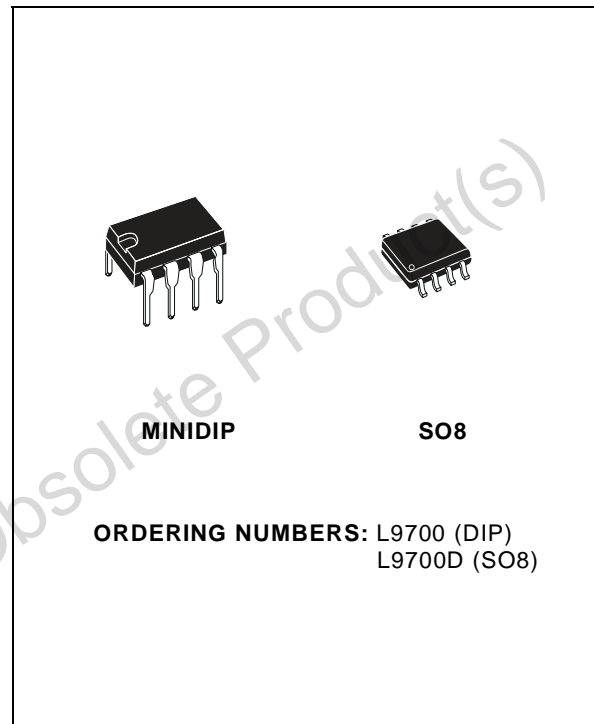

BLOCK DIAGRAM

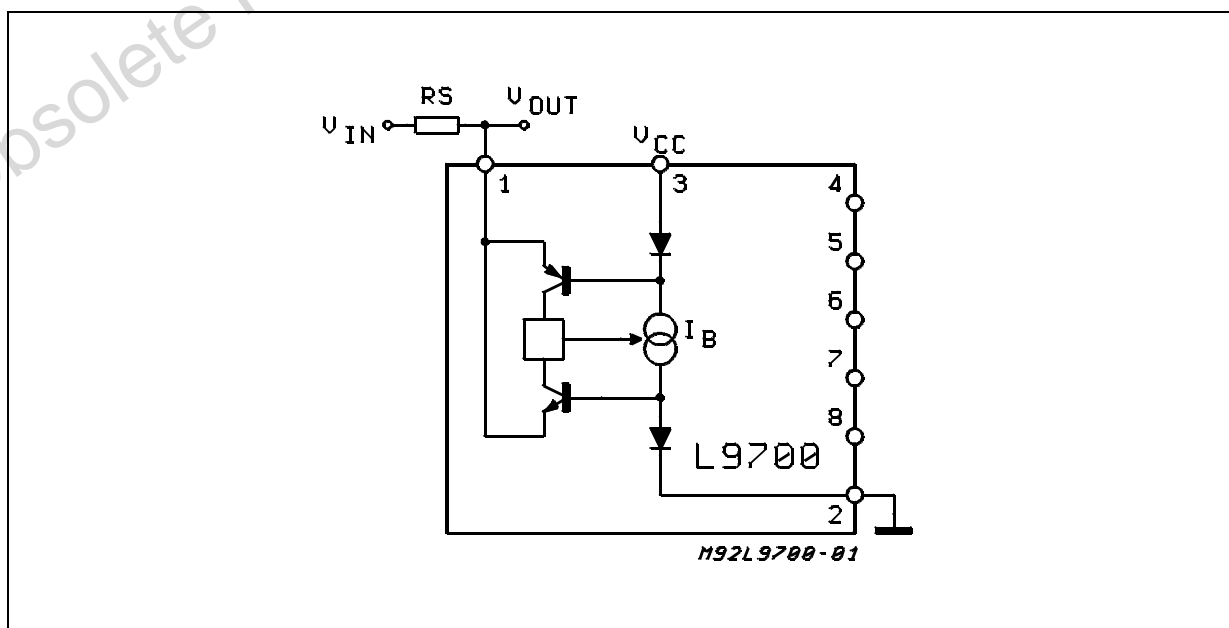

L9700

ABSOLUTE MAXIMUM RATINGS

Symbol	Parameter	Value	Unit
V_{CC}	Supply Voltage	20	V
I_{IN}	Input Current per Channel	30	mA
T_j, T_{stg}	Junction and Storage Temperature	-55 to 150	°C
P_{tot}	Total Power Dissipation ($T_{amb} = 85^\circ\text{C}$)	650	mW

Note: The circuit is ESD protected according to MIL-STD-883C

THERMAL DATA

Symbol	Parameter	MINIDIP	SO8	Unit
$R_{thj-amb}$	Thermal Resistance Junction to Ambient	Max. 100	200	°C/W

PIN CONNECTION

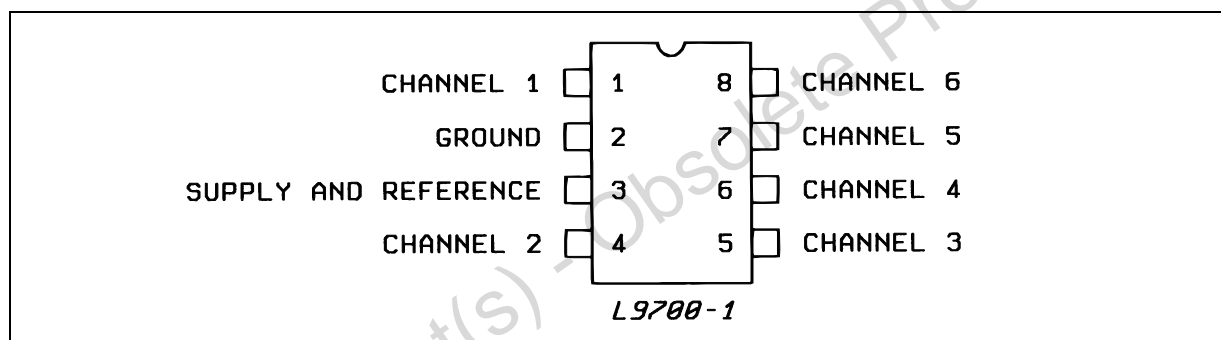

ELECTRICAL CHARACTERISTICS ($V_{CC} = 5\text{V}$, $T_J = -40$ to 125°C unless otherwise specified)

Symbol	Parameter	Test condition	Min.	Typ.	Max.	Unit
V_{CC}	Supply Voltage		4.75		5.25	V
I_{CC}	Supply Current			1.5	3	mA
V_{cis}	Static Input Clamping Voltage	Negative $I_{IN} = -10\text{mA}$ Positive $I_{IN} = +10\text{mA}$	-250 V_{CC}		0 $V_{CC}+250$	mV
I_{IN}	Input Current (static)	$V_{IN} = 0$ $V_{IN} = V_{CC}$ $V_{IN} = 50\text{mV}$ $V_{IN} = V_{CC} - 50\text{mV}$			15 15 5 5	μA μA μA μA
$V_{dd} (*)$	Dynamic Input Clamping Voltage	$I_{IN} = \pm 10\text{mA}$, $t_R = 5\text{ns}$ Positive Overshoot Negative Overshoot			400 400	mV mV
$t_s (*)$	Setting Time	See fig. 2			20	ns
$R_{IN} (*)$	Dynamic Input Resistance				5	Ω

(*) Design limits are guaranteed by statistical control on production samples over the indicated temperature and supply voltage ranges. These limits are not used to calculate outgoing quality levels.

Figure 1 : DC INPUT CHARACTERISTIC Limit Points of the Characteristic Approximation.

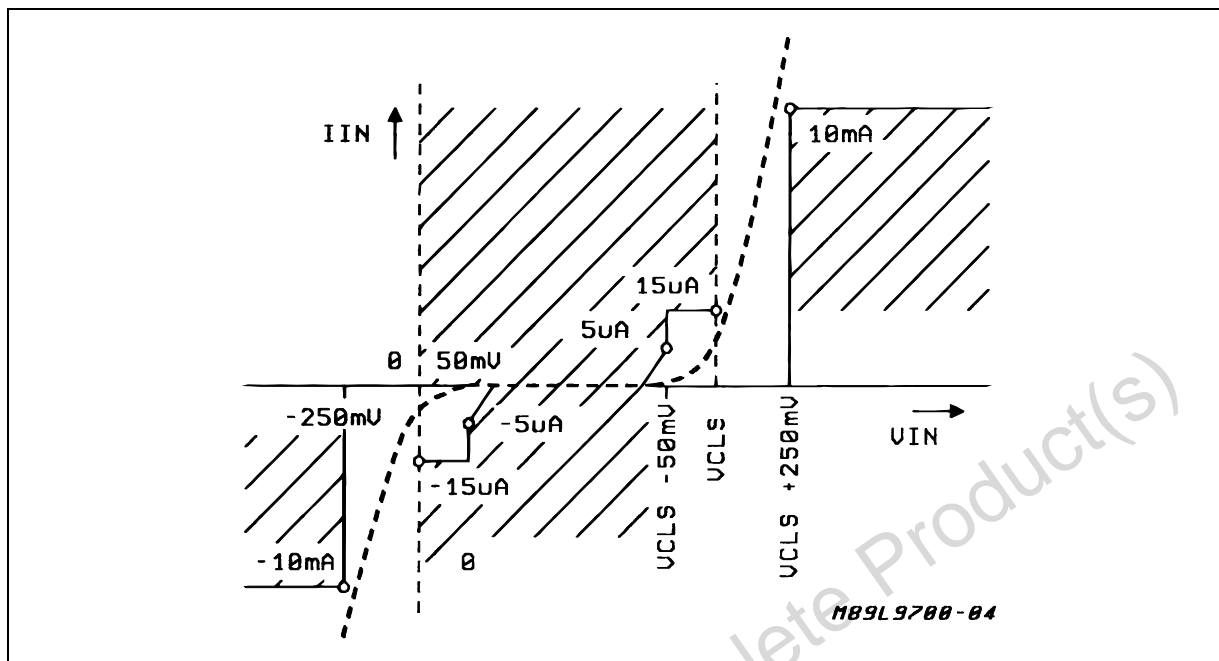

Figure 2 : Dynamical Input Characteristics.

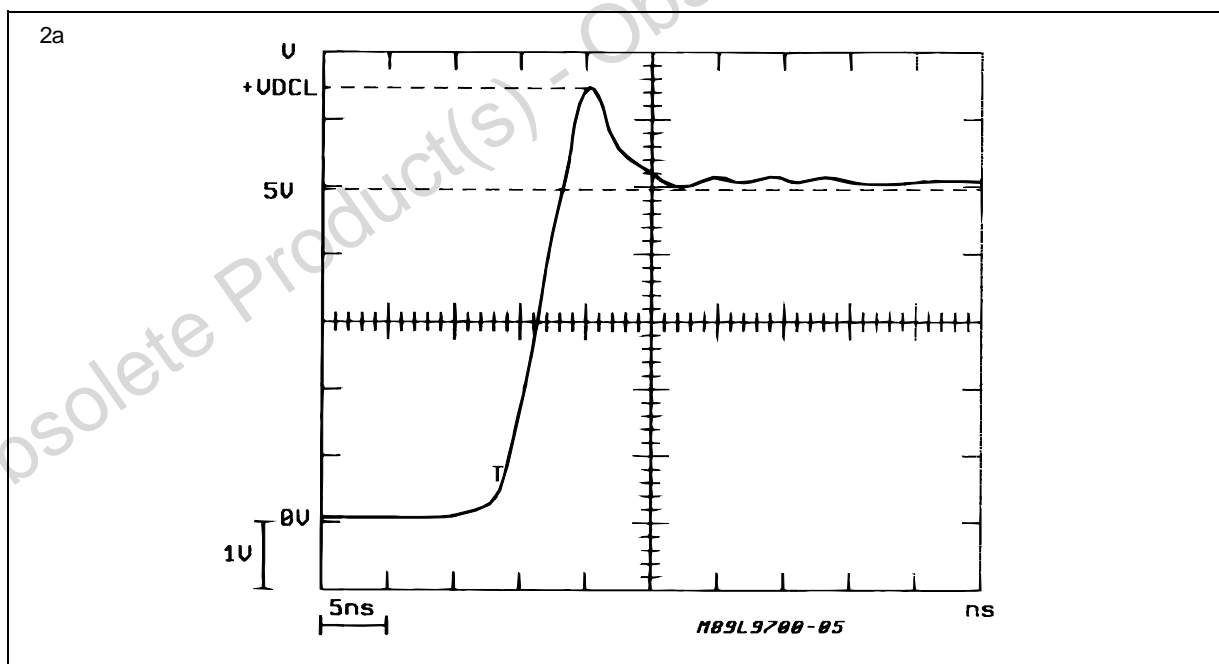
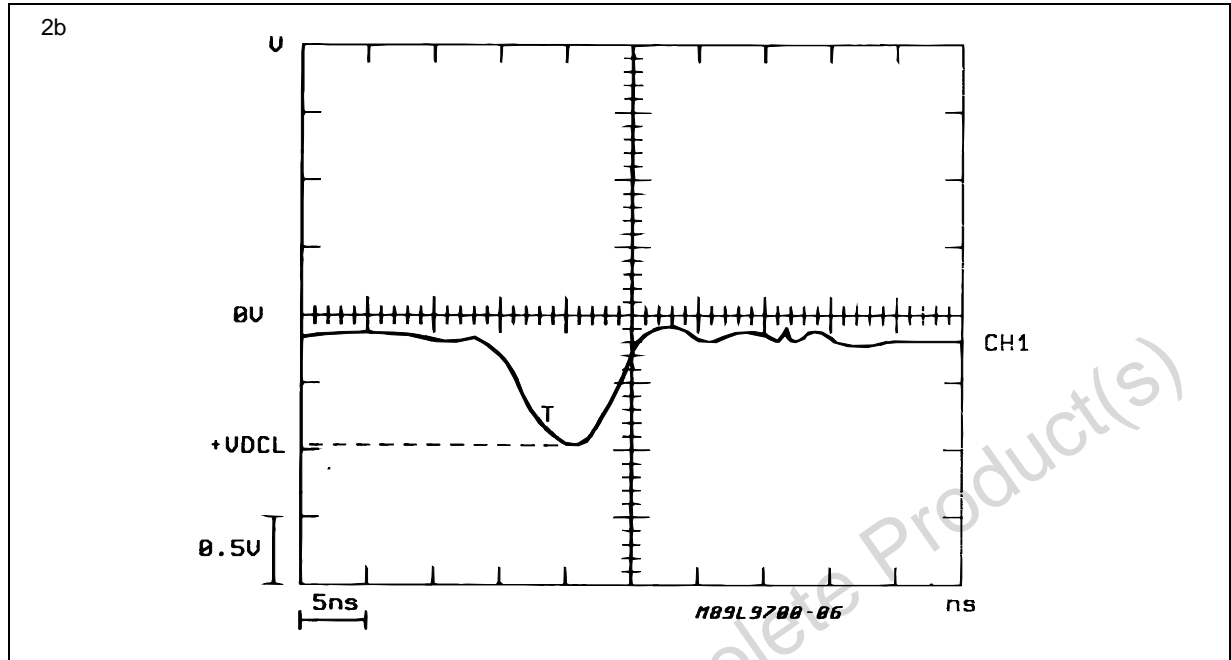

Figure 2 : Dynamical Input Characteristics (continued) .



APPLICATION INFORMATION

Most integrated circuits, both HNMOS and bipolar, are very sensitive to positive and negative overvoltages on the supply and at the inputs.

These transients occur in large numbers and with different magnitudes in the automotive environment, making adequate protection for devices aimed at it indispensable.

Overvoltages on the supply line are faced through high voltage integration technologies or through external protection (transil, varistor).

Signal inputs are generally protected using clamp diodes to the supply and ground, and a current limiter resistor. However, such solutions do not always completely satisfy the protection specifications in terms of intervention speed, negative clamping and current leakage high enough to change analog signals.

The L9700 device combines a high intervention speed with a high precision positive and negative

clamp and a low current leakage providing the optimal solution to the problems of the automotive environment.

The high intervention speed, due to the pre-bias of the limiter stage and internal feedback, limits the voltage overshoot and avoid the use of external capacitors for the limitation of the transient rise times.

Figure 3 illustrates a typical automotive application scheme. The resistor R_S limits the input current of the device and is therefore dimensioned considering the characteristics of the transients to be eliminated. Consequently :

$$R_S = \frac{V_{\text{transient Peak}}}{I_{\text{IN MAX}}}$$

The C_{IN} capacitors must be used only on analog inputs because they present a low impedance during the sampling period.

Figure 3 : Typical Application.

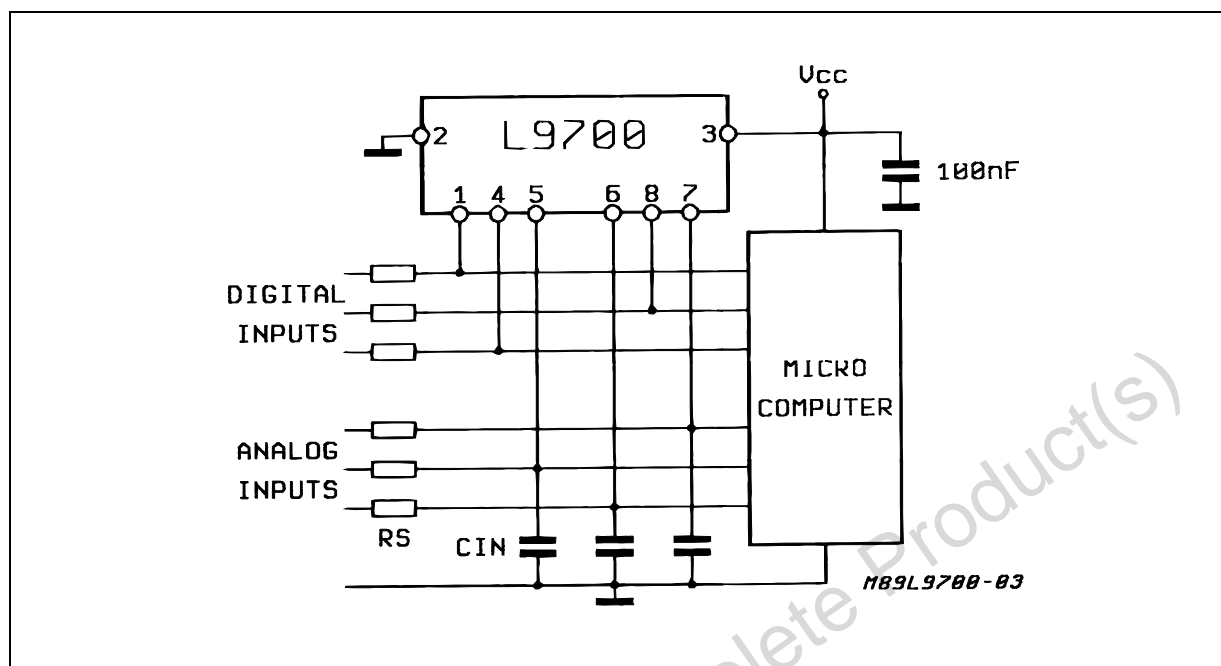

The minimum value for C_{IN} is determined by the accuracy required, the time taken to sample the input and the input impedance during that time, while the maximum value is determined by the required frequency response and the value of R_S .

Thus for a resistive input A/D converter where :

T_S = Sample time (Seconds)

R_D = Device input resistance (Ohms)

V_{IN} = Input voltage (Volts)

k = Required accuracy (%)

Q_1 = Charge on capacitor before sampling

Q_2 = Charge on capacitor after sampling

I_D = Device input current (Amps)

Thus :

$$Q_1 - Q_2 = \frac{k \cdot Q_1}{100}$$

but $Q_1 = C_{IN} V_{IN}$

and $Q_1 - Q_2 = I_D \cdot T_S$

so that $I_D T_S = \frac{k \cdot C_{IN} V_{IN}}{100}$

and $C_{IN} (\text{min}) = \frac{I_D \cdot T_S}{V_{IN} \cdot k}$ Farad

so $C_{IN} (\text{min}) = \frac{100 \cdot T_S}{k \cdot R_D}$ Farad

The calculation for a sample and hold type converter is even simpler :

k = Required accuracy (%)

C_H = Hold capacitor (Farad)

$$C_{IN} (\text{min}) = \frac{100 \cdot C_H}{k}$$
 Farad

L9700

DIM.	mm			inch		
	MIN.	TYP.	MAX.	MIN.	TYP.	MAX.
A		3.32			0.131	
a1	0.51			0.020		
B	1.15		1.65	0.045		0.065
b	0.356		0.55	0.014		0.022
b1	0.204		0.304	0.008		0.012
D			10.92			0.430
E	7.95		9.75	0.313		0.384
e		2.54			0.100	
e3		7.62			0.300	
e4		7.62			0.300	
F			6.6			0.260
I			5.08			0.200
L	3.18		3.81	0.125		0.150
Z			1.52			0.060

OUTLINE AND MECHANICAL DATA

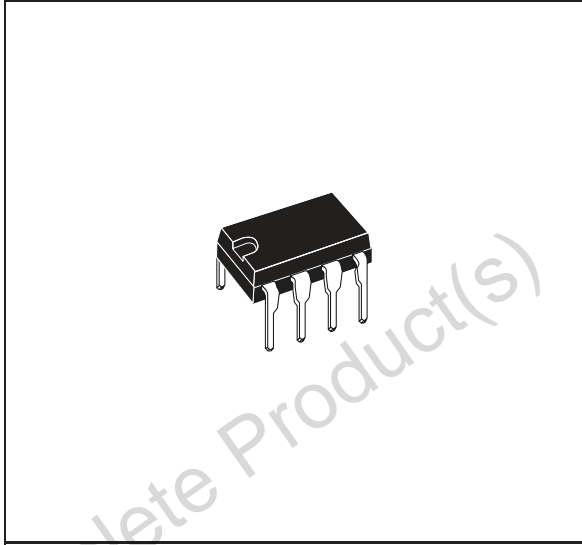

Minidip

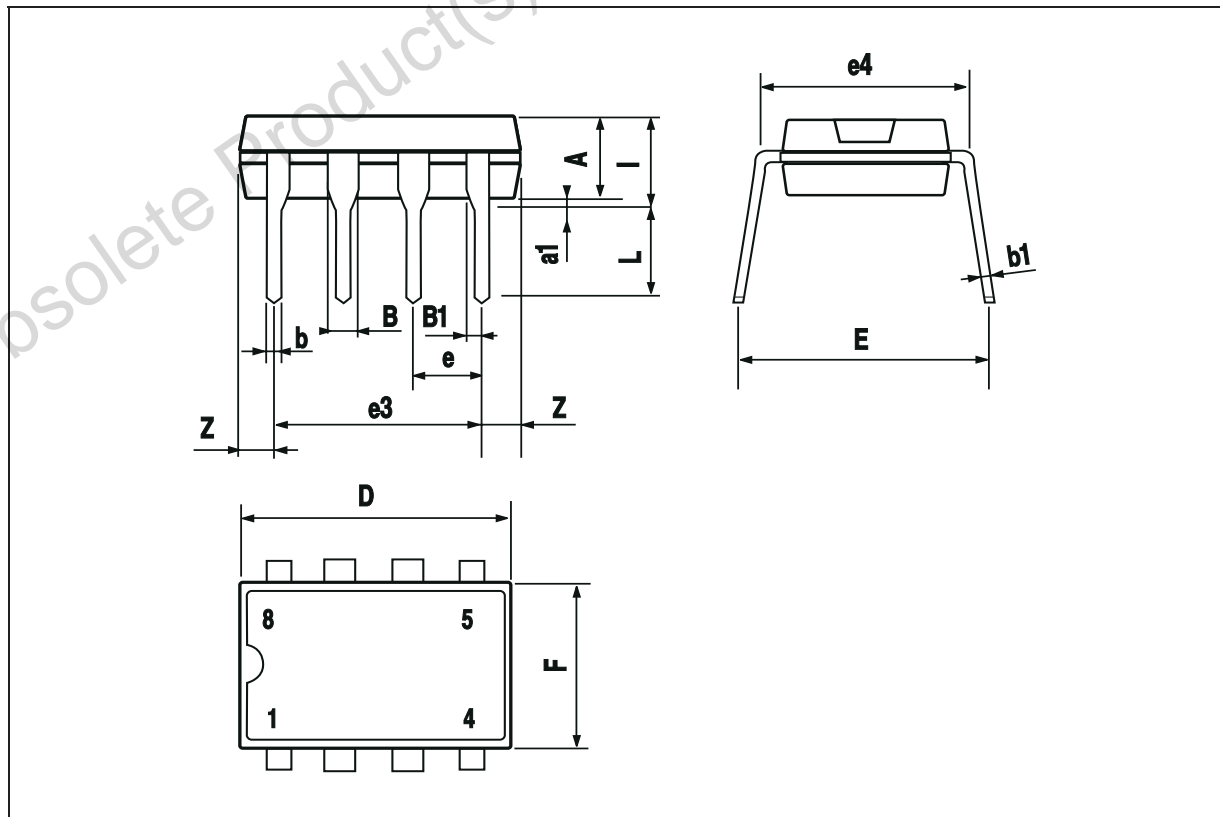

DIM.	mm			inch		
	MIN.	TYP.	MAX.	MIN.	TYP.	MAX.
A			1.75			0.069
a1	0.1		0.25	0.004		0.010
a2			1.65			0.065
a3	0.65		0.85	0.026		0.033
b	0.35		0.48	0.014		0.019
b1	0.19		0.25	0.007		0.010
C	0.25		0.5	0.010		0.020
c1	45° (typ.)					
D (1)	4.8		5.0	0.189		0.197
E	5.8		6.2	0.228		0.244
e		1.27			0.050	
e3		3.81			0.150	
F (1)	3.8		4.0	0.15		0.157
L	0.4		1.27	0.016		0.050
M			0.6			0.024
S	8° (max.)					

OUTLINE AND MECHANICAL DATA

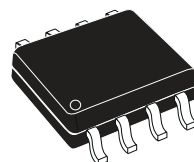

SO8

(1) D and F do not include mold flash or protrusions. Mold flash or protrusions shall not exceed 0.15mm (.006inch).

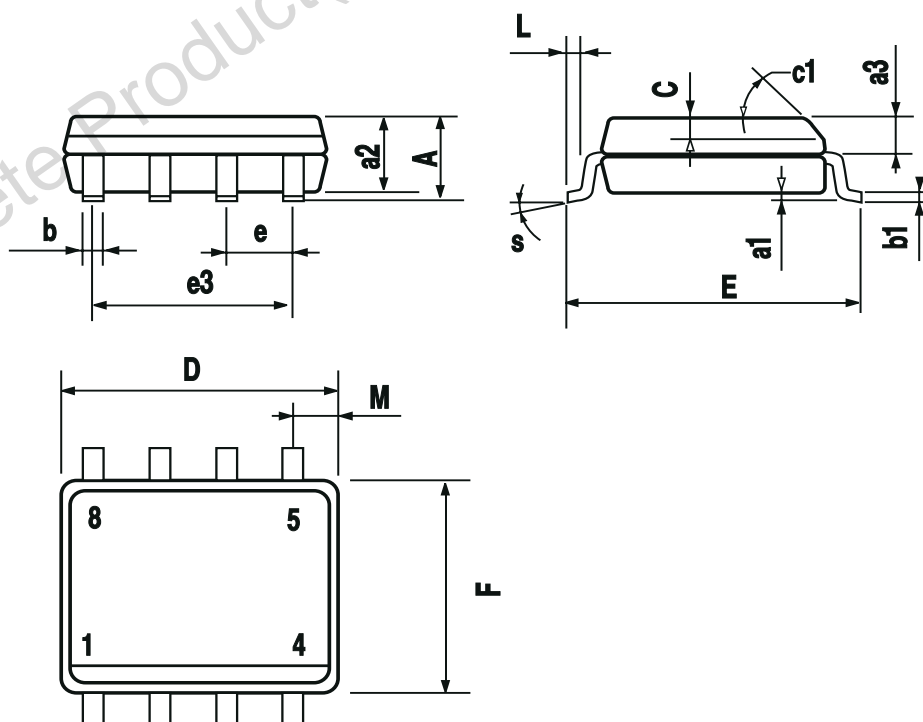

Obsolete Product(s) - Obsolete Product(s)

Information furnished is believed to be accurate and reliable. However, STMicroelectronics assumes no responsibility for the consequences of use of such information nor for any infringement of patents or other rights of third parties which may result from its use. No license is granted by implication or otherwise under any patent or patent rights of STMicroelectronics. Specification mentioned in this publication are subject to change without notice. This publication supersedes and replaces all information previously supplied. STMicroelectronics products are not authorized for use as critical components in life support devices or systems without express written approval of STMicroelectronics.

The ST logo is a registered trademark of STMicroelectronics
© 2000 STMicroelectronics – Printed in Italy – All Rights Reserved
STMicroelectronics GROUP OF COMPANIES

Australia - Brazil - China - Finland - France - Germany - Hong Kong - India - Italy - Japan - Malaysia - Malta - Morocco -
Singapore - Spain - Sweden - Switzerland - United Kingdom - U.S.A.

<http://www.st.com>