

Over	Up to and including	Tolerance
0	1000	±20
1000	3000	±30
3000	5000	±40
5000	10000	±50
10000	15000	±100
15000	20000	±150
20000		±L/100

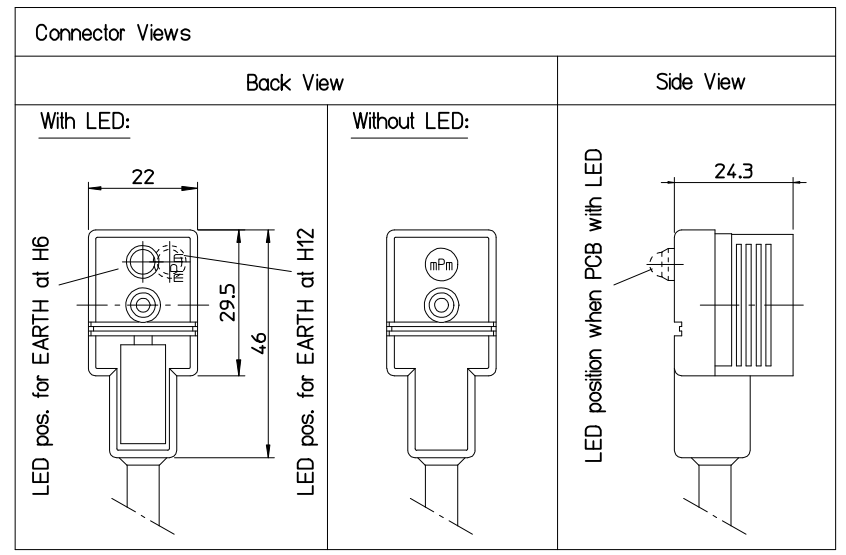

PART No MATRIX - PN Key

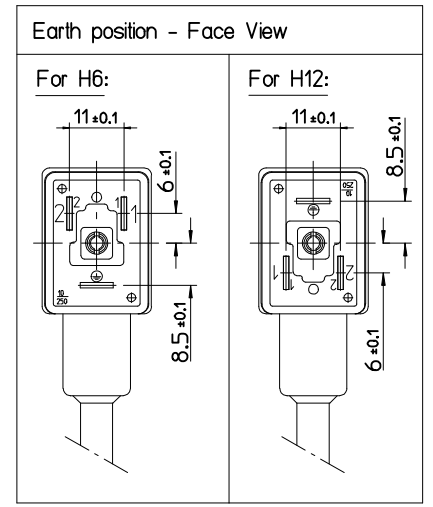
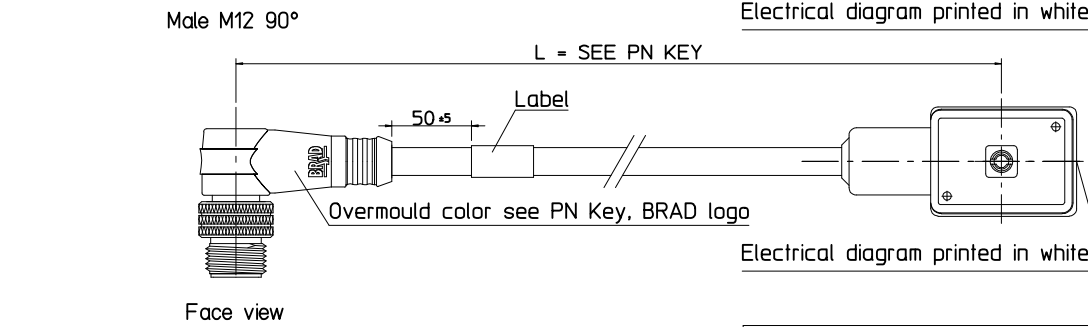
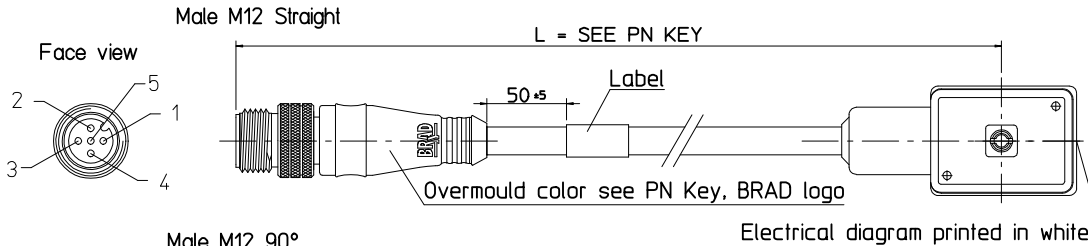
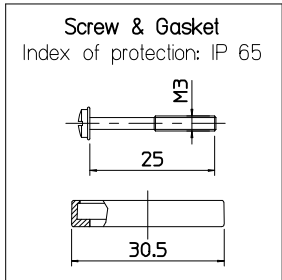
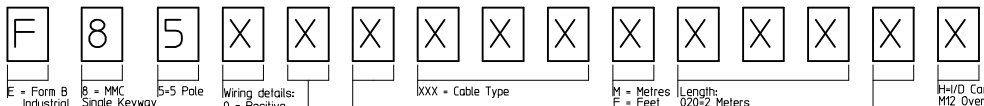

- F = Form B Industrial Standard (11mm contact spacing)
- 8 = MMC Single Keyway
- 5-5 Pale
- Wiring details: 0 = Positive Switching (pin 3&4), 1 = Negative Switching (pin 1&4)
- XXX = Cable Type
- M = Metres, F = Feet
- Lengths: 0-20 Meters, 0-5 Meters, 20-20 Meters
- Options: H/D Carrier, M12 Overmoulding color (Blank-Black Standard, Y=Yellow, A=Grey), Coupling Nut Material (Blank-Standard, 1=Stainless Steel, 5=Delrin, 7=Teflon coat)
- DN Earth Position - o'clock & M12 connector body: 0 = EARTH H6, MALE Straight, 1 = EARTH H12, MALE Straight, 2 = EARTH H6, MALE 90°, 3 = EARTH H12, MALE 90°
- Electrical configurations: 0 = Without LED/without circuit, A = S0 24V Yellow LED, B = C4 24V Yellow LED, C = S0 110V Yellow LED, D = C4 110V Yellow LED, E = S0 24V Green LED, F = C4 24V Green LED, G = S0 110V Green LED, H = C4 110V Green LED, J = S0 24V Red LED, K = C4 24V Red LED, L = S0 110V Red LED, M = C4 110V Red LED, S = C4 230V Yellow LED

ADD CABLE B31 EC NO: IPGZ014-0850 DRWN: JMARSZALEK 2013/11/07 CHKD: MSZWAJKOWSKI 2013/11/07 APPR: MIWASIECZKO 2013/11/08	QUALITY SYMBOLS 	GENERAL TOLERANCES (UNLESS SPECIFIED)		DIMENSION STYLE MM ONLY		SCALE	DESIGN UNITS	FIRST ANGLE PROJECTION																																
						METRIC																																		
		<table border="1"> <thead> <tr> <th></th> <th>mm</th> <th>INCH</th> </tr> </thead> <tbody> <tr> <td>4 PLACES</td> <td>± ---</td> <td>± ---</td> </tr> <tr> <td>3 PLACES</td> <td>± ---</td> <td>± ---</td> </tr> <tr> <td>2 PLACES</td> <td>± ---</td> <td>± ---</td> </tr> <tr> <td>1 PLACE</td> <td>± ---</td> <td>± ---</td> </tr> <tr> <td>0 PLACE</td> <td>± ---</td> <td>± ---</td> </tr> </tbody> </table>			mm	INCH	4 PLACES		± ---	± ---	3 PLACES	± ---	± ---	2 PLACES	± ---	± ---	1 PLACE	± ---	± ---	0 PLACE	± ---	± ---	<table border="1"> <thead> <tr> <th>DRAWN BY</th> <th>DATE</th> </tr> </thead> <tbody> <tr> <td>JMARSZALEK</td> <td>2012/11/08</td> </tr> <tr> <th>CHECKED BY</th> <th>DATE</th> </tr> <tr> <td>MSZWAJKOWSKI</td> <td>2012/11/08</td> </tr> <tr> <th>APPROVED BY</th> <th>DATE</th> </tr> <tr> <td>MIWASIECZKO</td> <td>2013/11/08</td> </tr> </tbody> </table>		DRAWN BY	DATE	JMARSZALEK	2012/11/08	CHECKED BY	DATE	MSZWAJKOWSKI	2012/11/08	APPROVED BY	DATE	MIWASIECZKO	2013/11/08	TITLE F85XXXXXXXXXX DIN B IND + CORDSETS M12			
			mm	INCH																																				
4 PLACES	± ---	± ---																																						
3 PLACES	± ---	± ---																																						
2 PLACES	± ---	± ---																																						
1 PLACE	± ---	± ---																																						
0 PLACE	± ---	± ---																																						
DRAWN BY	DATE																																							
JMARSZALEK	2012/11/08																																							
CHECKED BY	DATE																																							
MSZWAJKOWSKI	2012/11/08																																							
APPROVED BY	DATE																																							
MIWASIECZKO	2013/11/08																																							
DRAFT WHERE APPLICABLE MUST REMAIN WITHIN DIMENSIONS		ANGULAR ± --- °		SEE SHEET 3		DOCUMENT NO. SD-121036-002		SHEET NO. 1 OF 3																																

Electrical diagrams

Electrical diagram with circuit S0 (zener diode) for:

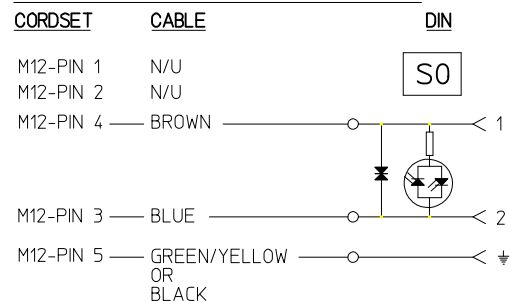

Electrical diagram with circuit C4 (VDR) for:

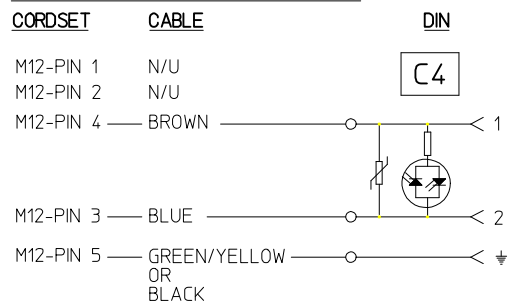

Cable type

Cable Type	Jacket Material	Jacket Color	Wire cross section	Braid
A23	PVC	Black	0.75mm ²	no
A58	PVC	Black	20AWG	no
B08	PUR	Yellow	18AWG	no
E03	PVC	Black	0.34mm ²	no
E12	PVC	Black	0.5mm ²	no
I12	CEI PVC	Grey	0.5mm ²	no
P12	PUR	Black	0.5mm ²	no
P82	PUR IRR	Orange	0.34mm ²	no
S26	PVC	Yellow	0.34mm ²	yes
B31	PUR	Black	0.5mm ²	no

ADD CABLE B31 EC NO: IPG2014-0850 DRWN: JMARSZALEK 2013/11/07 CHKD: MSZWAJKOWSKI 2013/11/07 APPR: MIWASIECZKO 2013/11/08	QUALITY SYMBOLS	GENERAL TOLERANCES (UNLESS SPECIFIED)	DIMENSION STYLE	SCALE	DESIGN UNITS	FIRST ANGLE PROJECTION	
	=0 =0	mm INCH 4 PLACES ± --- ± --- 3 PLACES ± --- ± --- 2 PLACES ± --- ± --- 1 PLACE ± --- ± --- 0 PLACE ± --- ± --- ANGULAR ± --- °	MM ONLY	1:1	METRIC		
	DESCRIPTION	DRAFT WHERE APPLICABLE MUST REMAIN WITHIN DIMENSIONS	DRAWN BY: JMARSZALEK DATE: 2012/11/08 CHECKED BY: MSZWAJKOWSKI DATE: 2012/11/08 APPROVED BY: MIWASIECZKO DATE: 2013/11/08	TITLE	F85XXXXXXXXXX DIN B IND + CORDSETS M12		
	REV		SEE SHEET 3	MATERIAL NO.	DOCUMENT NO.		
	B					SD-121036-002	SHEET NO. 2 OF 3

PART LIST

Pos.	Molex PN:	Engineering No.:	Pos.	Molex PN:	Engineering No.:	Pos.	Molex PN:	Engineering No.:	Pos.	Molex PN:	Engineering No.:	Pos.	Molex PN:	Engineering No.:
1	1210350196	F85000E12M050	41	1210360606	F850B1E12M010	81	1210360901	F850B0B31M006	121			161		
2	1210350197	F85000E12M060	42	1210360607	F850B1P12M003	82	1210360902	F850B0B31M010	122			162		
3	1210350216	F85001E12M003	43	1210360608	F850B1P12M008	83	1210360903	F850B0B31M015	123			163		
4	1210350217	F85001E12M030	44	1210360609	F850B1P12M070	84	1210360904	F850B0B31M030	124			164		
5	1210350286	F85000P12M006	45	1210360660	F850B0A58M006	85	1210360905	F850B2B31M006	125			165		
6	1210350287	F85000P12M010	46	1210360661	F850B0A58M015	86	1210360906	F850B2B31M010	126			166		
7	1210350288	F85000P12M020	47	1210360670	F850B3B08M050	87	1210360907	F850B2B31M015	127			167		
8	1210350303	F85000E12M006	48	1210360671	F850A0A58M100	88	1210360908	F850B2B31M030	128			168		
9	1210350312	F85000E12M030	49	1210360673	F850B0P82M015	89			129			169		
10	1210350325	F85000E12M003	50	1210360674	F850B0E12M050	90			130			170		
11	1210350344	F85000P12M011	51	1210360690	F850A0A58M005	91			131			171		
12	1210350345	F85000P12M009	52	1210360691	F850B0A58M010	92			132			172		
13	1210350346	F85000P12M012	53	1210360693	F850B0A58M030	93			133			173		
14	1210350347	F85000P12M013	54	1210360728	F850B0A23M010	94			134			174		
15	1210360247	F850A3P12M010	55	1210360740	F850A3A58M050	95			135			175		
16	1210360248	F850A3P12M040	56	1210360741	F850B1A58M100	96			136			176		
17	1210360251	F850B0I12M006	57	1210360759	F850B0P82M005	97			137			177		
18	1210360252	F850B0I12M010	58	1210360763	F850A0A58M070	98			138			178		
19	1210360255	F850B0P12M010	59	1210360790	F850D0P12M006	99			139			179		
20	1210360256	F850B0P12M020	60	1210360791	F850D0P12M020	100			140			180		
21	1210360257	F850B0P12M030	61	1210360800	F850A0P12M006	101			141			181		
22	1210360352	F850B0P12M006	62	1210360801	F850C0P12M006	102			142			182		
23	1210360398	F850B1P12M020	63	1210360802	F850A0P12M010	103			143			183		
24	1210360437	F850B1E03M010	64	1210360803	F850C0P12M010	104			144			184		
25	1210360461	F850B0P12M050	65	1210360804	F850A0P12M020	105			145			185		
26	1210360462	F850B1P12M006	66	1210360805	F850C0P12M020	106			146			186		
27	1210360463	F850B1P12M010	67	1210360806	F850B1P12M0087	107			147			187		
28	1210360464	F850D0P12M010	68	1210360809	F850B0I12M020	108			148			188		
29	1210360499	F850B1P82M010	69	1210360810	F850B1P82M0087	109			149			189		
30	1210360502	F850A0A58M030	70	1210360811	F850B1P82M0067	110			150			190		
31	1210360503	F850A0A58M050	71	1210360818	F850B0I12M010Y	111			151			191		
32	1210360504	F850B0A58M100	72	1210360820	F850B0I12M020Y	112			152			192		
33	1210360505	F850B2P12M006	73	1210360822	F850B0P12M015	113			153			193		
34	1210360506	F850B2P12M010	74	1210360823	F850B2P12M015	114			154			194		
35	1210360545	F850B0E12M010	75	1210360824	F850B2P12M030	115			155			195		
36	1210360548	F850B1E12M006	76	1210360839	F850B0P82M0067	116			156			196		
37	1210360561	F850B2E12M010	77	1210360840	F850B0P82M0067Y	117			157			197		
38	1210360571	F850B0P82M0107	78	1210360860	F850B0P12M010H	118			158			198		
39	1210360603	F850B0A58M020	79	1210360863	F850B1P12M015	119			159			199		
40	1210360605	F850B0E12M020	80	1210360865	F850B0P12M020H	120			160			200		

ADD NEW PN'S EC NO: IPG2014-0850 DRWN: JMARSZALEK 2013/11/07 CHKD: MSZWAJKOWSKI 2013/11/07 APPR: MIWASIECZKO 2013/11/08	QUALITY SYMBOLS ▽=0 ◻=0	GENERAL TOLERANCES (UNLESS SPECIFIED)		DIMENSION STYLE MM ONLY		SCALE 1:1	DESIGN UNITS METRIC	FIRST ANGLE PROJECTION	
			mm	INCH	DRAWN BY JMARSZALEK	DATE 2012/11/08	TITLE F85XXXXXXXXXX DIN B IND + CORDSETS M12		
		4 PLACES	± ---	± ---	CHECKED BY MSZWAJKOWSKI	DATE 2012/11/08	 DOCUMENT NO. SD-121036-002 SHEET NO. 3 OF 3		
		3 PLACES	± ---	± ---	APPROVED BY MIWASIECZKO	DATE 2013/11/08			
2 PLACES	± ---	± ---	ANGULAR ±---°		MATERIAL NO.		SEE TABLE		
1 PLACE	± ---	± ---	DRAFT WHERE APPLICABLE MUST REMAIN WITHIN DIMENSIONS		SIZE A3	THIS DRAWING CONTAINS INFORMATION THAT IS PROPRIETARY TO MOLEX INCORPORATED AND SHOULD NOT BE USED WITHOUT WRITTEN PERMISSION			
0 PLACE	± ---	± ---							