

REVISIONS

P	LTR	DESCRIPTION	DATE	DWN	APVD
	E2	ECR-19-006127	10APR2019	RZ	RS

NOTES:

- ① SINGLE PACK IN ACCORDANCE WITH AMP SPEC 107-3275
- ② 100 TRAY PACK IN ACCORDANCE WITH AMP SPEC 107-3275
- ③ FLASH Au PLATING
- ④ 0.8µm Au PLATING
- ⑤ Ni PLATING
- ⑥ THIS ITEM MUST BE WHITE

- 7. HAND TOOL : 9-1478240-0
- 8. DIE SET : 9-1478242-0

9. ELECTRICAL CHARACTERISTICS

FREQUENCY RANGE:	DC - 4 GHz
NOMINAL IMPEDANCE:	50 Ohm
INSULATION RESISTANCE:	5000 MOhm
WORKING VOLTAGE:	500 Volts RMS at Sea Level
DIELECTRIC WITHSTAND VOLTAGE:	1500 Volts RMS Max
CONTACT RESISTANCE:	
CENTRE CONTACT:	1.50 mOhm Max
OUTER CONTACT:	0.20 mOhm Max
VSWR @ 4GHz:	1.30:1 Max
INSERTION LOSS dB @ x 3 GHz:	0.20 Max

10. MECHANICAL CHARACTERISTICS

COUPLING NUT RETENTION FORCE:	445N Min
CABLE RETENTION FORCE:	120N Min
DURABILITY:	500 Cycles Min

11. ENVIRONMENTAL CHARACTERISTICS

OPERATING TEMPERATURE:	-65 to +165 DegC
------------------------	------------------

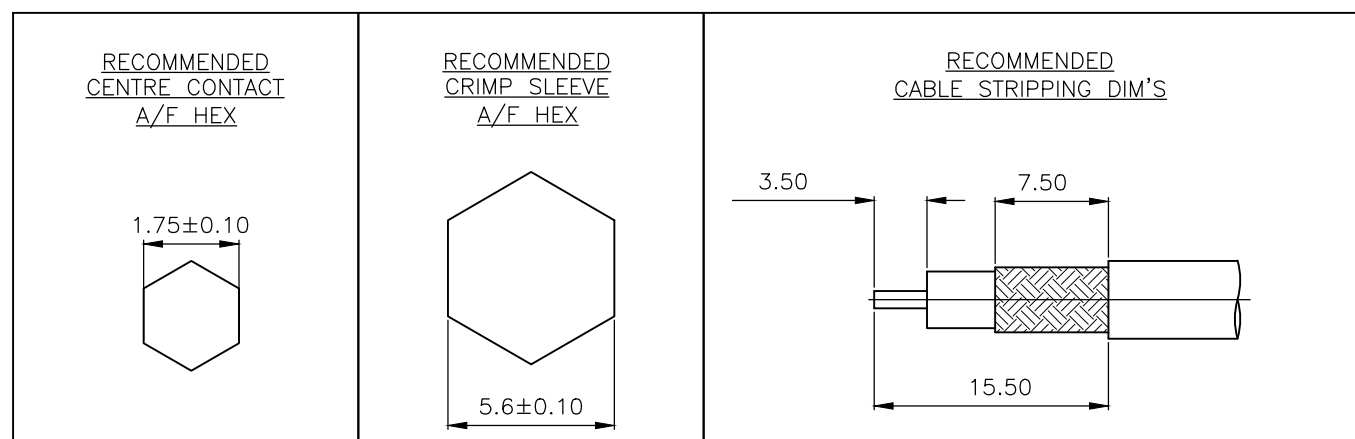
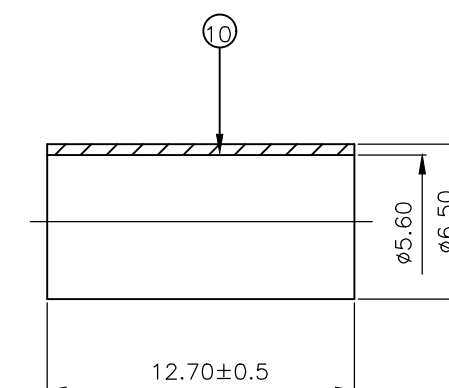
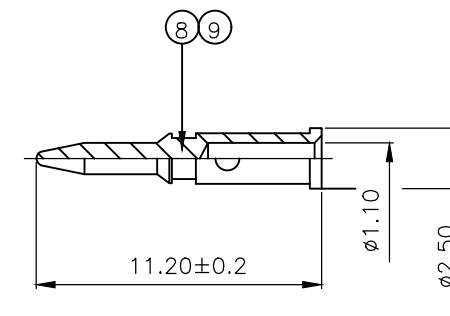
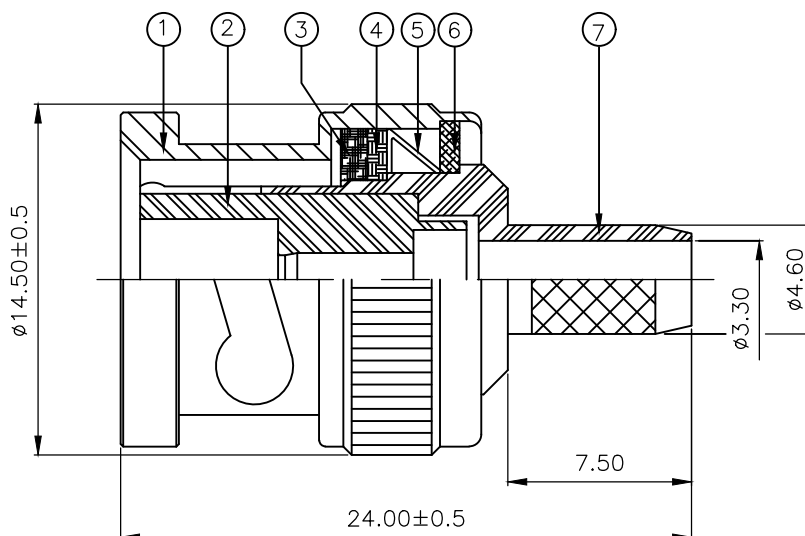

QTY	PLC	QTY	PLC	MATERIAL	DESCRIPTION	ITEM
1	1	1	1	BRASS	FERRULE	10
1	1	-	-	BRASS	CONTACT	9
-	-	1	1	BRASS	CONTACT	8
1	1	1	1	BRASS	BODY	7
1	1	1	1	BRASS	WASHER	6
1	1	1	1	SPRING STEEL	SPRING	5
1	1	1	1	BRASS	WASHER	4
1	1	1	1	SILICON RUBBER	GASKET	3
1	1	1	1	PTFE	INSULATION	2
1	1	1	1	BRASS	SHELL	1

QTY	PLC	QTY	PLC	MATERIAL	DESCRIPTION	ITEM
6--1	1--1	6--0	1--0			

THIS DRAWING IS A CONTROLLED DOCUMENT.		DWN J.SANDWELL 12SEPT05		TE Connectivity	
DIMENSIONS: mm		CHK S.PARLOW 12SEPT05			
TOLERANCES UNLESS OTHERWISE SPECIFIED:		APVD F.WHEELER-KING 12SEPT05		NAME	
0 PLC ± -		PRODUCT SPEC		BNC STRAIGHT PLUG CRIMP 50 OHM	
1 PLC ± -		APPLICATION SPEC		RG58C/U, 141A/U, URM 43 & 76, KX15	
2 PLC ± 0.1		411-3247		BELDEN 9907	
3 PLC ± -		WEIGHT 0.000000		SIZE A3	CAGE CODE 00779
4 PLC ± -		CUSTOMER DRAWING		DRAWING NO C-1337426	RESTRICTED TO -
ANGLES ± -		SCALE NTS		SHEET 1 OF 1	REV E2
FINISH SEE TABLE					