

# LED StackJack™

## Modular Jacks

### Networking Solutions

Our space-saving StackJack™ modular jacks offer the most features for the maximum reliability and performance you need for today's integrated data systems from the central office all the way through to your mobile applications. Our enhanced shielding provides optimum protection against EMI, and our unique panel tabs provide a high normal force for superior shielding effectiveness. The longer springs allow repeated insertions / withdrawals from a panel, and prevent "fish hooking" on the panel during insertion.

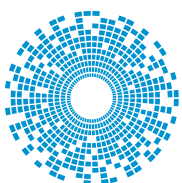

**stewart**  
CONNECTOR  
a bel group

# LED StackJack™

All of the Stewart StackJack™ modular jacks can be equipped with EPP-918A contact dressing to increase the durability of the contacts to withstand heavy insertions and extractions of the mating plugs and provide increased protection in harsh environments.

## Specification

- Plastic Materials: UL 94V-0 Rated Glass-Filled Thermoplastics
- Contact Material: Copper Alloy
- Contact Plating: Selective Gold Plate in the Contact Interface Area
- Current Rating: 1.5 Amps (max)
- Voltage Rating: 150 VAC (max)
- Operating Temperature: -40°C to 85°C

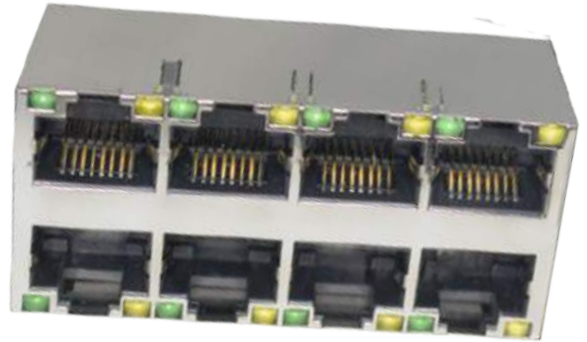

## Design Features

- CAT3 to CAT5E connectors are available in shielded and unshielded configurations to support Gigabit Ethernet
- Jack dimensions meet FCC requirements when plated with 50 microinches of gold
- Jacks are UL approved and DUXR2 and DUXR8 certified



# How to Order Stewart Connector's LED StackJack™

Part Number	Port Configurations	Shielded	LED Color	LED Type
SS-74500-018	2 x 1	Yes	Yellow/Green	Upper/Lower Bi-color LED
SS-74500-020	2 x 2	Yes	Yellow/Green	Upper/Lower LED
SS-74500-012	2 x 4	Yes	Orange/Green	Upper Bi-color LED
SS-74500-016	2 x 4	Yes	Green/Green	Upper/Lower LED
SS-74500-024	2 x 4	Yes	Yellow/Green	Upper/Lower LED
SS-74500-010	2 x 6	Yes	Orange/Green	Upper Bi-color LED
SS-74500-014	2 x 6	Yes	Green/Green	Upper/Lower LED
SS-74500-026	2 x 6	Yes	Yellow/Green	Upper/Lower LED
SS-74500-022	2 x 8	Yes	Yellow/Green	Upper/Lower LED



# LED StackJack™

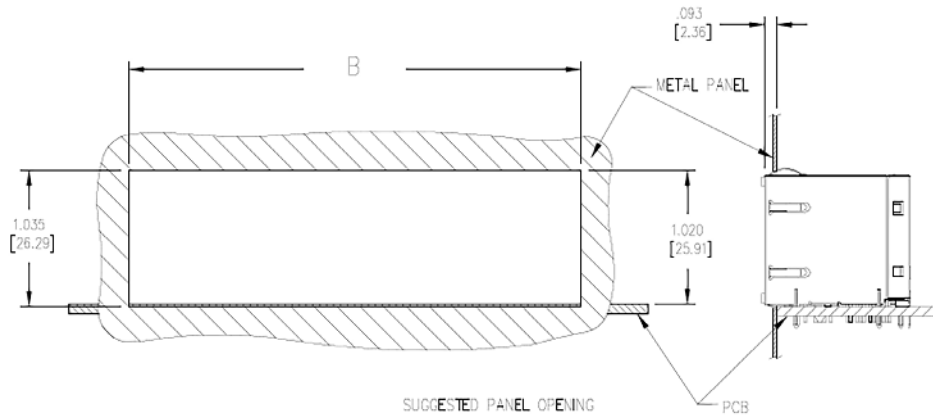

Dimensions Chart					
Dimensions	Ports				
	2 (2x1)	4 (2x2)	8 (2x4)	12 (2x6)	16 (2x8)
A	0.676 [17.17]	1.226 [31.14]	2.326 [59.08]	3.426 [87.02]	4.526 [114.96]
B	0.706 [17.93]	1.256 [31.90]	2.365 [60.07]	3.465 [88.01]	4.556 [115.72]

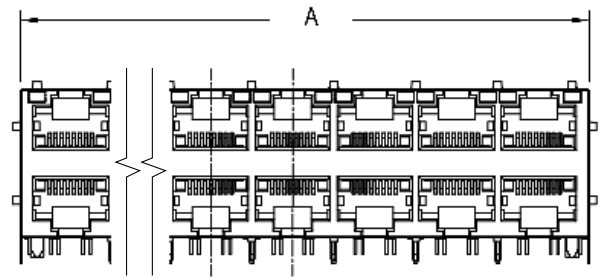

Custom designs are available on request.  
Email [techhelp@belf.com](mailto:techhelp@belf.com) to submit your specific application needs.

Data sheets with electrical and mechanical specifications are available at [stewartconnector.com](http://stewartconnector.com)



Stewart Connector  
11118 Susquehanna Trail South  
Glen Rock, PA 17327 USA

+1 717.235.7512  
[techhelp@belf.com](mailto:techhelp@belf.com)  
[stewartconnector.com](http://stewartconnector.com)