

General Description

The AOZ8915CI is a transient voltage suppressor array designed to protect high speed data lines such as USB 2.0 and Gigabit Ethernet from damaging ESD events.

This device incorporates eight surge rated, low capacitance steering diodes and a TVS in a single package. During transient conditions, the steering diodes direct the transient to either the positive side of the power supply line or to ground.

The AOZ8915CI provides low insertion loss up to 3GHz providing greater signal integrity making it ideally suited for USB 2.0 applications, such as Digital TVs, DVD players, Computing, set-top boxes, and mobile computing devices.

The AOZ8915CI comes in RoHS compliant and halogen free SOT23-6L package and is rated -40°C to +85°C junction temperature range.

Features

- ESD protection for high-speed data lines:
 - IEC 61000-4-2, level 4 (ESD) immunity test
 - $\pm 30\text{kV}$ (air discharge) and $\pm 24\text{kV}$ (contact discharge)
 - IEC61000-4-4 (EFT) 40A (5/50ns)
 - IEC61000-4-5 (Lightning) 12A (8/20 μs)
 - Human Body Model (HBM) $\pm 30\text{kV}$
- Array of surge rated diodes with internal TVS diode
- Protects four I/O lines
- Low clamping voltage
- Low operating voltage: 5.0V

Applications

- USB 2.0 ports
- Monitors and flat panel displays
- Set-top box
- Video graphics cards
- Notebook computers



Typical Application

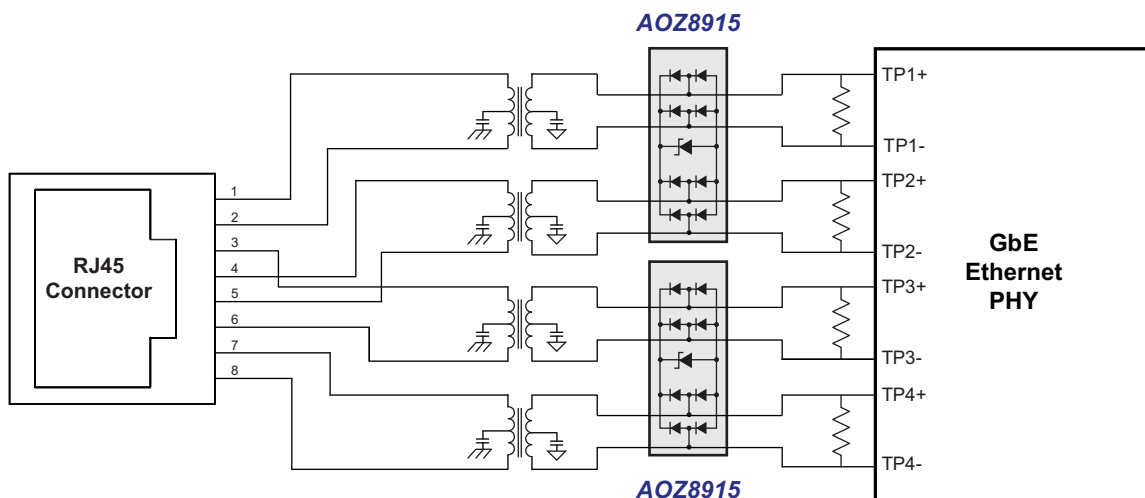

Figure 1. 10/100/1000 Ethernet Port Connection

Ordering Information

Part Number	Ambient Temperature Range	Package	Environmental
AOZ8915CI	-40°C to +85°C	SOT23-6L	RoHS Compliant Green Product



AOS Green Products use reduced levels of Halogens, and are also RoHS compliant. Please visit www.aosmd.com/media/AOSGreenPolicy.pdf for additional information.

Pin Configuration

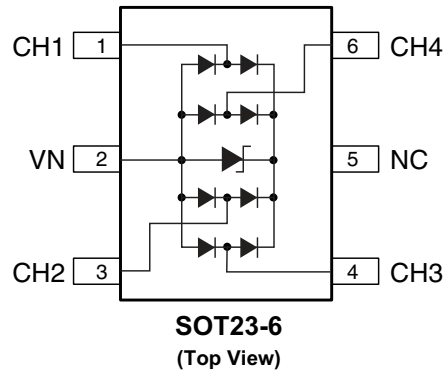

Absolute Maximum Ratings

Exceeding the Absolute Maximum ratings may damage the device.

Parameter	Rating
Storage Temperature (T_S)	-65°C to +150°C
ESD Rating per IEC61000-4-2, contact ⁽¹⁾	±24kV
ESD Rating per IEC61000-4-2, air ⁽¹⁾	±30kV
Lighting IEC61000-4-5 (8/20µs) Positive	+12A
Lighting IEC61000-4-5 (8/20µs) Negative	-6A
ESD Rating per Human Body Model ⁽²⁾	±30kV

Notes:

- IEC 61000-4-2 discharge with $C_{Discharge} = 150\text{pF}$, $R_{Discharge} = 330\Omega$.
- Human Body Discharge per MIL-STD-883, Method 3015 $C_{Discharge} = 100\text{pF}$, $R_{Discharge} = 1.5\text{k}\Omega$.

Maximum Operating Ratings

Parameter	Rating
Junction Temperature (T_J)	-40°C to +125°C

Electrical Characteristics

$T_A = 25^\circ\text{C}$ unless otherwise specified.

Symbol	Parameter	Conditions	Min.	Typ.	Max.	Units
V_{RWM}	Reverse Working Voltage	Between I/O and VN ⁽³⁾			5.0	V
V_{BR}	Reverse Breakdown Voltage	$I_T = 100\mu\text{A}$, between I/O and VN ⁽⁴⁾	6.0			V
I_R	Reverse Leakage Current	$V_{RWM} = 5\text{V}$, between I/O and VN			1	μA
V_F	Diode Forward Voltage	$I_F = 15\text{mA}$	0.70	0.85	1	V
V_{CL}	Channel Clamp Voltage Positive Transients Negative Transient	$I_{PP} = 1\text{A}$, $t_p = 100\text{ns}$, any I/O pin to Ground ⁽⁵⁾⁽⁶⁾			8.0 -3.5	V V
	Channel Clamp Voltage Positive Transients Negative Transient	$I_{PP} = 5\text{A}$, $t_p = 100\text{ns}$, any I/O pin to Ground ⁽⁵⁾⁽⁶⁾			12.0 -6.0	V V
	Channel Clamp Voltage Any I/O Pin to Ground	$I_{PP} = 2\text{A}$, $t_p = 8/20\mu\text{s}$ ⁽⁶⁾			8.5	V
C_j	Channel Input Capacitance	$V_R = 0\text{V}$, $f = 1\text{MHz}$, any I/O pin to Ground		1.0	1.5	pF
		$V_R = 0\text{V}$, $f = 1\text{MHz}$, between I/O pins		0.5	0.8	pF

Notes:

- The working peak reverse voltage, V_{RWM} , should be equal to or greater than the DC or continuous peak operating voltage level.
- V_{BR} is measured at the pulse test current I_T .
- Measurements performed using a 100ns Transmission Line Pulse (TLP) system.
- The parameters are guaranteed by design and characterization.

Typical Performance Characteristics

TLP Current vs. Clamping Voltage

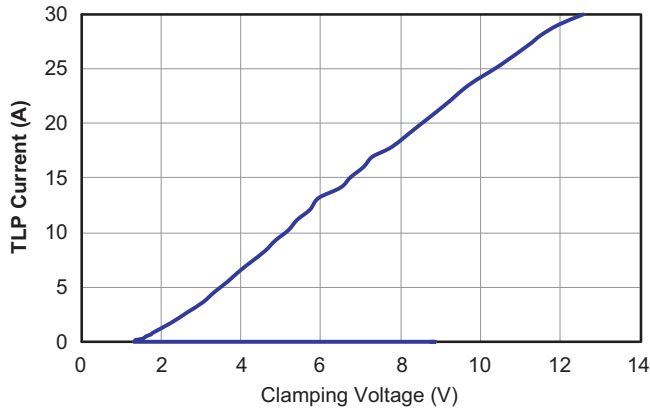

Forward Voltage vs. Forward Current

($t_{period} = 100ns, t_r = 1ns$)

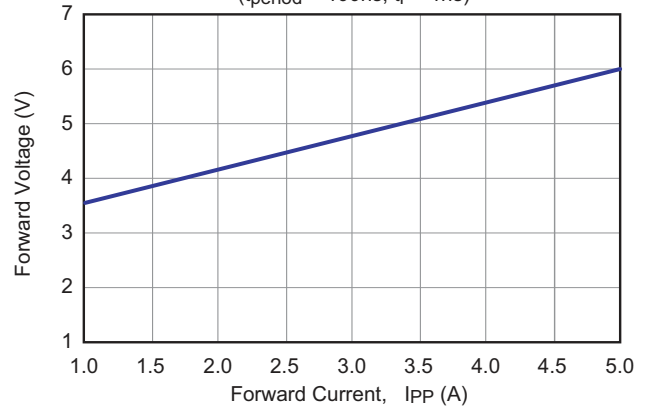

Typical Variation of C_{IN} vs. V_R

($f = 1MHz, T = 25^\circ C$)

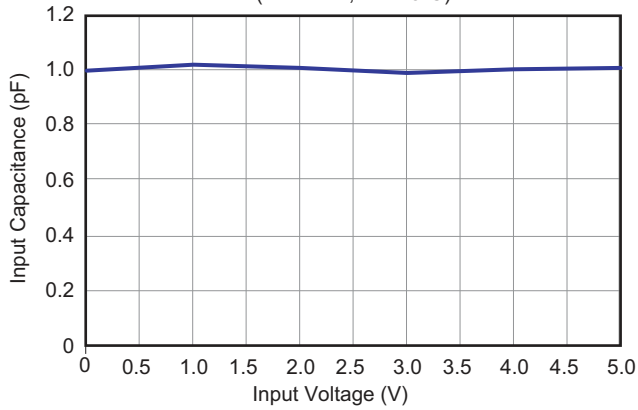

AOZ8915 I/O to I/O Capacitance

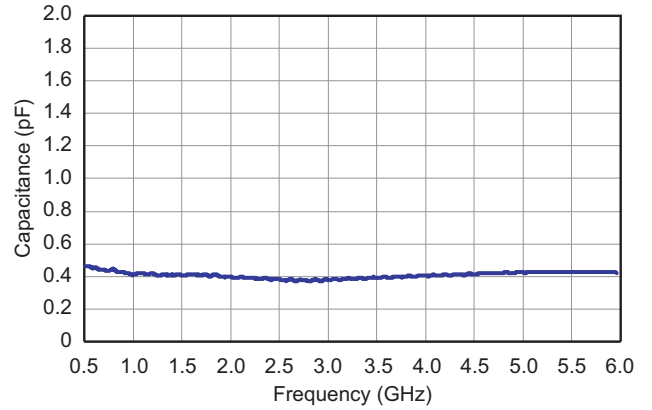

Analog Crosstalk (I/O to I/O) vs. Frequency

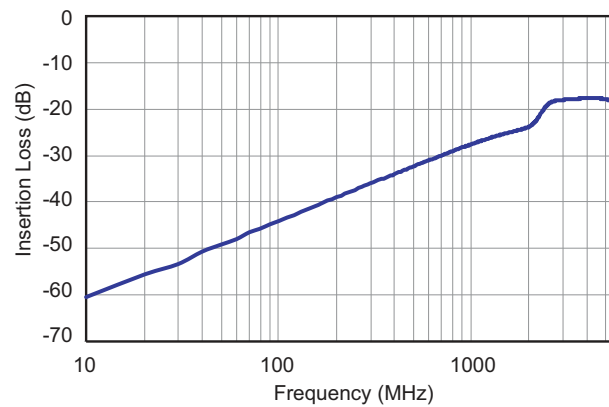

LEGAL DISCLAIMER

Applications or uses as critical components in life support devices or systems are not authorized. Alpha and Omega Semiconductor does not assume any liability arising out of such applications or uses of its products. AOS reserves the right to make changes to product specifications without notice. It is the responsibility of the customer to evaluate suitability of the product for their intended application. Customer shall comply with applicable legal requirements, including all applicable export control rules, regulations and limitations.

AOS' products are provided subject to AOS' terms and conditions of sale which are set forth at:

http://www.aosmd.com/terms_and_conditions_of_sale

LIFE SUPPORT POLICY

ALPHA AND OMEGA SEMICONDUCTOR PRODUCTS ARE NOT AUTHORIZED FOR USE AS CRITICAL COMPONENTS IN LIFE SUPPORT DEVICES OR SYSTEMS.

As used herein:

1. Life support devices or systems are devices or systems which, (a) are intended for surgical implant into the body or (b) support or sustain life, and (c) whose failure to perform when properly used in accordance with instructions for use provided in the labeling, can be reasonably expected to result in a significant injury of the user.
2. A critical component in any component of a life support, device, or system whose failure to perform can be reasonably expected to cause the failure of the life support device or system, or to affect its safety or effectiveness.