

## Programmable Current-Limit High-Side Switch

### Features

- 2.7V to 5.5V Input
- Adjustable Current-Limit up to 1.5A
- Reverse Current Flow Blocking (No “Body Diode”)
- 75  $\mu$ A Typical On-State Supply Current
- 1  $\mu$ A Typical Off-State Supply Current
- 120 m $\Omega$  Maximum On-Resistance
- Open-Drain Fault Flag
- Thermal Shutdown
- Thermal Shutdown Output Latch (MIC2548)
- 2 ms (Slow) Turn-On and Fast Turn-Off
- Available with Active-High or Active-Low Enable

### Applications

- USB Power Distribution
- PCI Bus Power Switching
- Notebook PC
- ACPI Power Distribution
- PC Card Hot Swap Applications
- Inrush Current-Limiting

### General Description

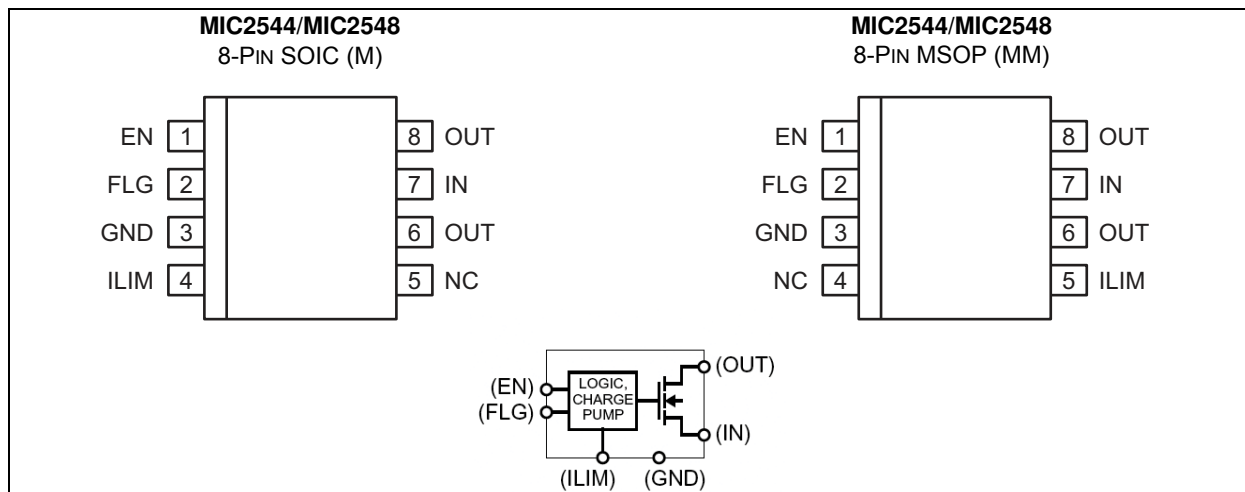
The MIC2544 and MIC2548 are integrated, high-side power switches optimized for low-loss DC power switching and other power management applications, including Advanced Configuration and Power Interface (ACPI). The MIC2544/48 are cost-effective, highly integrated solutions that require few external components to satisfy USB and ACPI requirements.

Load current management features include a precision resistor-programmable output current-limit and a soft-start circuit that minimizes inrush current when the switch is enabled. Thermal shutdown, along with current-limit, protects the switch and the attached device.

The MIC2544/48’s open-drain flag output is used to indicate current-limiting or thermal shutdown to a local controller. The MIC2548 has an additional internal latch that turns the output off upon thermal shutdown, providing robust fault control. The enable signal is compatible with both 3V and 5V logic, and is also used as the thermal shutdown latch reset for the MIC2548.

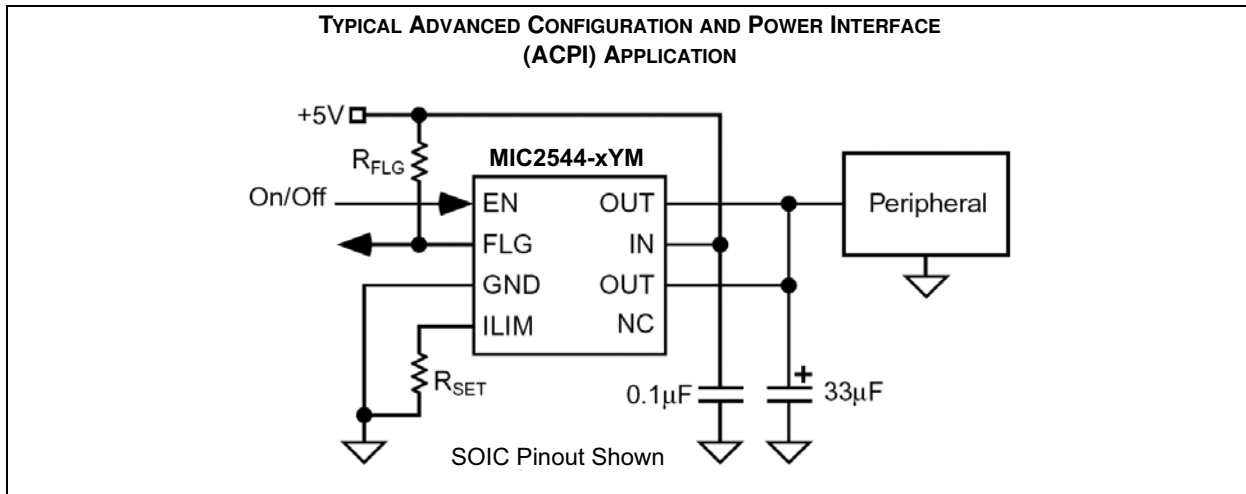
The MIC2544 and MIC2548 are available in active-high and active-low enable versions in the 8-pin SOIC and 8-pin MSOP packages.

### Package Types

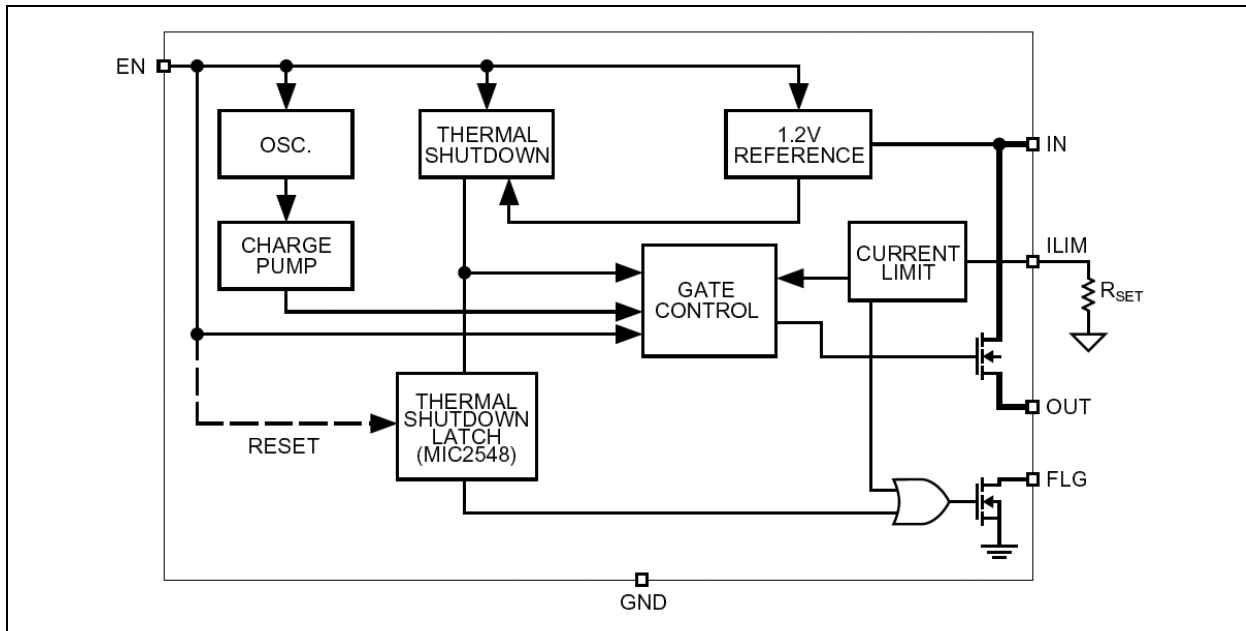


# MIC2544/48

## Typical Application Circuit



## Functional Diagram



## 1.0 ELECTRICAL CHARACTERISTICS

### Absolute Maximum Ratings †

Supply Voltage ( $V_{IN}$ ) .....	+7.0V
Output Voltage ( $V_{OUT}$ ) .....	-0.3V to +7.0V
Output Current ( $I_{OUT}$ ) .....	Internally Limited
Enable Input ( $V_{EN}$ ) .....	-0.3V to $V_{IN}+0.3V$
Fault Flag Voltage ( $V_{FLG}$ ) .....	+7.0V
Fault Flag Current ( $I_{FLG}$ ) .....	50 mA
ESD Rating (Note 1) .....	2 kV

### Operating Ratings ‡

Supply Voltage ( $V_{IN}$ ) .....	+2.7V to +5.5V
Current Limit Set Range .....	0.1A to 1.5A

† **Notice:** Stresses above those listed under “Absolute Maximum Ratings” may cause permanent damage to the device. This is a stress rating only and functional operation of the device at those or any other conditions above those indicated in the operational sections of this specification is not intended. Exposure to maximum rating conditions for extended periods may affect device reliability.

‡ **Notice:** The device is not guaranteed to function outside its operating ratings.

**Note 1:** Devices are ESD sensitive. Handling precautions recommended. Human body model, 1.5 k $\Omega$  in series with 100 pF.

# MIC2544/48

**TABLE 1-1: ELECTRICAL CHARACTERISTICS (Note 1)**

**Electrical Characteristics:**  $V_{IN} = +5V$ ;  $T_A = 25^\circ C$ , bold values indicate  $-40^\circ C$  to  $+85^\circ C$ , unless noted.

Parameter	Symbol	Min.	Typ.	Max.	Units	Conditions
Supply Current	$I_{IN}$	—	0.75	5	$\mu A$	Switch off, OUT = Open (Note 2)
		—	75	160		Switch on, OUT = Open (Note 2)
Enable Input Voltage	$V_{EN}$	2.4	1.7	—	V	Enable High, (Note 2)
		—	1.5	0.8		Enable Low, (Note 2)
Enable Input Capacitance	—	—	1	—	$\mu F$	Note 3
Switch Resistance	$R_{DS(ON)}$	—	80	120	$m\Omega$	$I_{OUT} = 500\text{ mA}$
Current Limit Factor	—	184	230	276	V	$I_{OUT} = 100\text{ mA to }1A$ , $V_{OUT} = 1V\text{ to }4V$ , (Note 4)
		161	230	299		$I_{OUT} = 500\text{ mA to }1.5A$ , $V_{OUT} = 1V\text{ to }4V$ , (Note 4)
Output Leakage Current	—	—	1	10	$\mu A$	Switch off
Output Turn-On Delay	$t_{ON}$	1	2	5	ms	$R_L = 10\Omega$ , $C_L = 1\ \mu F$ , Figure 4-2, Figure 4-3
Output Turn-On Rise Time	$t_R$	1	2	5	ms	$R_L = 10\Omega$ , $C_L = 1\ \mu F$ , Figure 4-2, Figure 4-3
Output Turn-Off Delay	$t_{OFF}$	—	22	—	$\mu s$	$R_L = 10\Omega$ , $C_L = 1\ \mu F$ , Figure 4-2, Figure 4-3
Output Turn-Off Fall Time	$t_F$	—	21	—	$\mu s$	$R_L = 10\Omega$ , $C_L = 1\ \mu F$ , Figure 4-2, Figure 4-3
Overtemperature Threshold Shutdown	—	—	140	—	$^\circ C$	$T_J$ increasing
		—	130	—		$T_J$ decreasing
Error Flag Output Resistance	—	—	4	15	$\Omega$	$V_{IN} = 5V$ , $I_L = 10\ \mu A$
		—	5	20		$V_{IN} = 3.3V$ , $I_L = 10\ \mu A$
Error Flag Off Current	—	—	0.01	1	$\mu A$	$V_{FLG} = 5V$
EN Pulse Reset Width	—	5	—	—	$\mu s$	MIC2548 thermal shutdown latch
$V_{IN}$ to EN Set-Up	—	0	—	—	$\mu s$	MIC2548, (Note 4)
Current-Limit Response Time	—	—	25	—	$\mu s$	$V_{OUT} = 0V$ , (Note 4)
Overcurrent Flag Response Time	—	—	5	—	$\mu s$	$V_{OUT} = V_{IN}/2$ to FLG low.

**Note 1:** Specification for packaged product only.

**2:** Off is  $\leq 0.8V$  and on is  $\geq 2.4V$  for the MIC2544-1 and MIC2548-1. Off is  $\geq 2.4V$  and on is  $\leq 0.8V$  for the MIC2544-2 and MIC2548-2. The enable input has about 200 mV of hysteresis.

**3:** Guaranteed by design but not production tested.

**4:** Current limit threshold is determined by  $I_{LIMIT} = 230V/R_{SET}$ , where  $R_{SET}$  is in ohms.

## TEMPERATURE SPECIFICATIONS (Note 1)

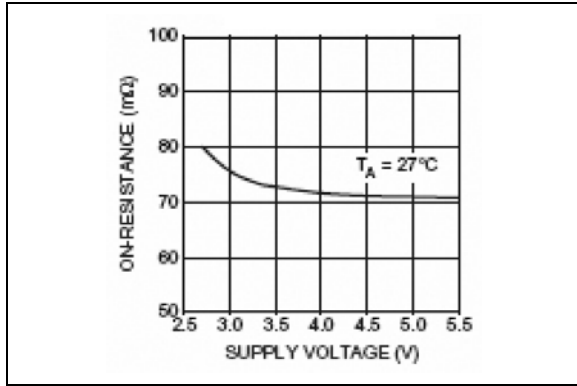
Parameters	Sym.	Min.	Typ.	Max.	Units	Conditions
<b>Temperature Ranges</b>						
Storage Temperature Range	$T_S$	-65	—	+150	°C	—
Lead Temperature	—	—	—	+260	°C	Soldering, 5 sec.
Junction Temperature	$T_J$	—	—	—	°C	Internally Limited
Ambient Temperature	$T_A$	-40	—	+85	°C	—
<b>Package Thermal Resistance</b>						
Thermal Resistance, 8-Ld SOIC	$\theta_{JA}$	—	160	—	°C/W	—
Thermal Resistance, 8-Ld MSOP	$\theta_{JA}$	—	206	—	°C/W	—

**Note 1:** The maximum allowable power dissipation is a function of ambient temperature, the maximum allowable junction temperature and the thermal resistance from junction to air (i.e.,  $T_A$ ,  $T_J$ ,  $\theta_{JA}$ ). Exceeding the maximum allowable power dissipation will cause the device operating junction temperature to exceed the maximum +125°C rating. Sustained junction temperatures above +125°C can impact the device reliability.

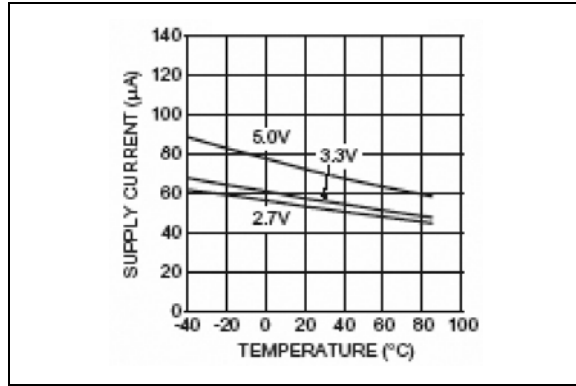
# MIC2544/48

## 2.0 TYPICAL PERFORMANCE CURVES

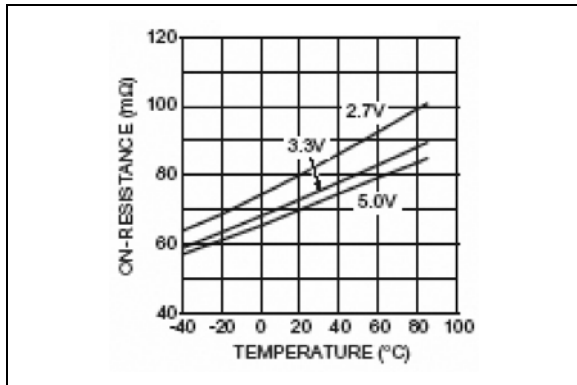
**Note:** The graphs and tables provided following this note are a statistical summary based on a limited number of samples and are provided for informational purposes only. The performance characteristics listed herein are not tested or guaranteed. In some graphs or tables, the data presented may be outside the specified operating range (e.g., outside specified power supply range) and therefore outside the warranted range.



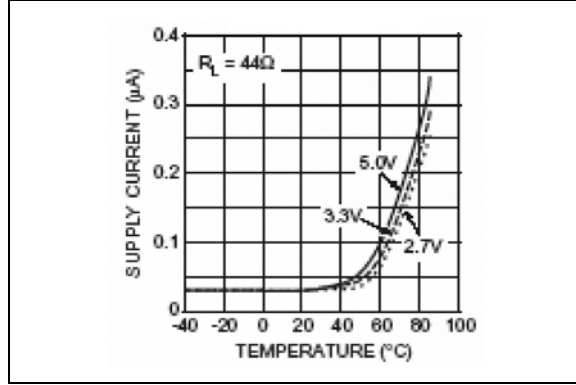
**FIGURE 2-1:** Output On-Resistance vs. Supply Voltage.



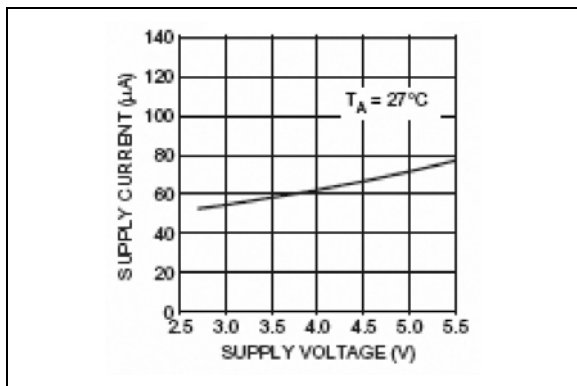
**FIGURE 2-4:** On-State Supply Current vs. Temperature.



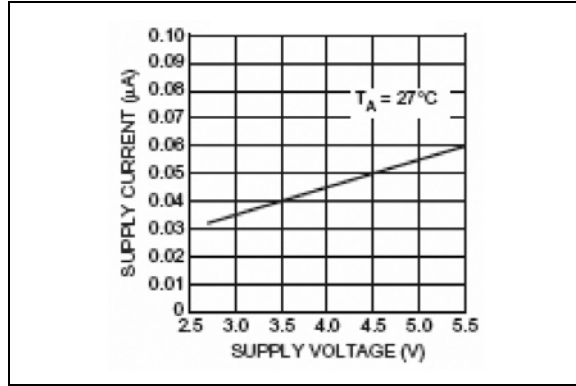
**FIGURE 2-2:** Output On-Resistance vs. Temperature.



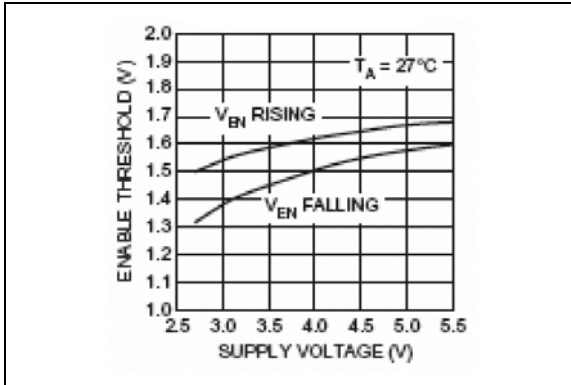
**FIGURE 2-5:** Off-State Supply Current vs. Temperature.



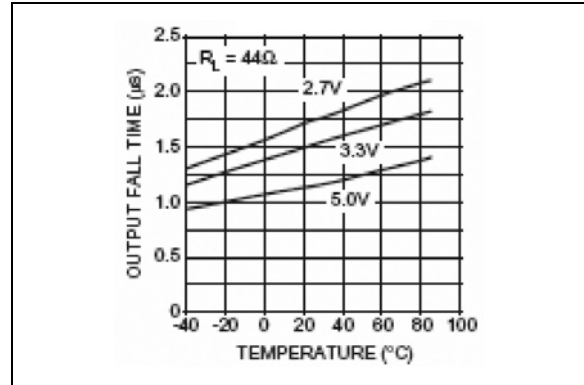
**FIGURE 2-3:** On-State Supply Current vs. Supply Voltage.



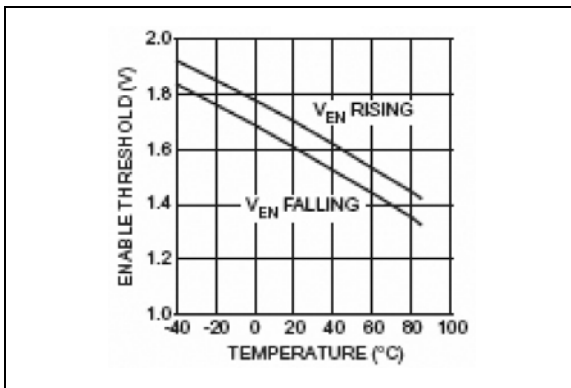
**FIGURE 2-6:** Off-State Supply Current vs. Supply Voltage.



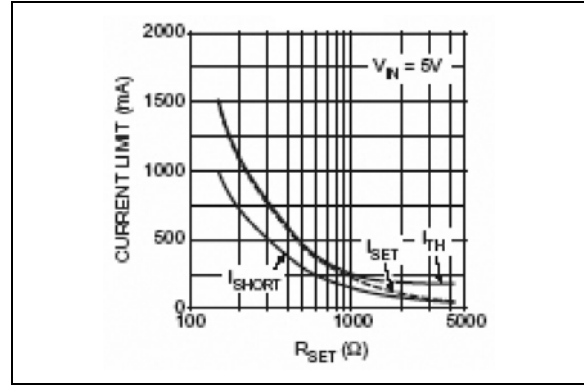
**FIGURE 2-7:** Enable Threshold Voltage vs. Supply Voltage.



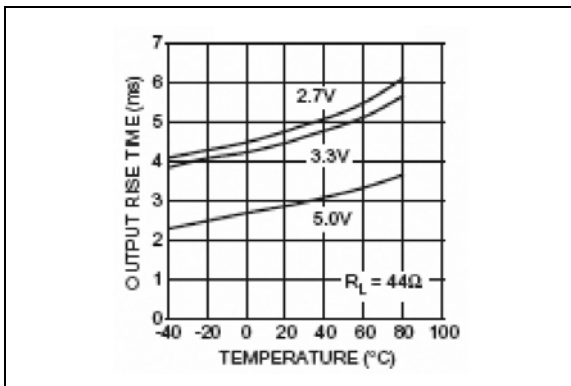
**FIGURE 2-10:** Output Fall Time vs. Temperature.



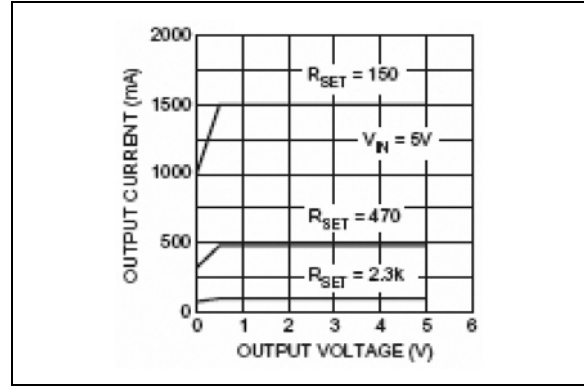
**FIGURE 2-8:** Enable Threshold Voltage vs. Temperature.



**FIGURE 2-11:** Current Limit vs.  $R_{SET}$ .

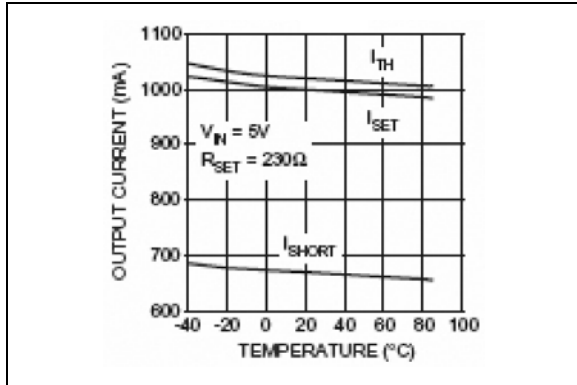


**FIGURE 2-9:** Rise Time vs. Temperature.

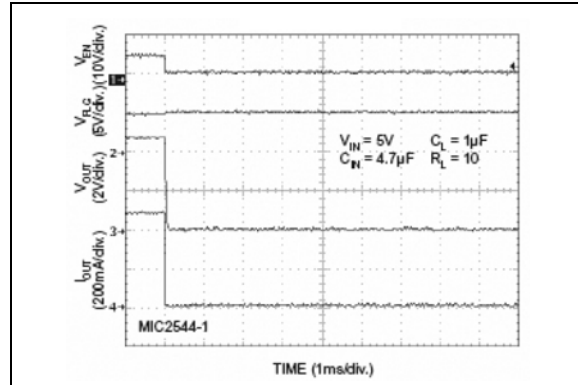


**FIGURE 2-12:** Output Current vs. Output Voltage.

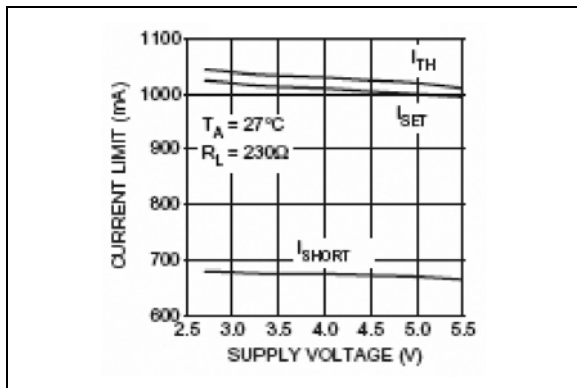
# MIC2544/48



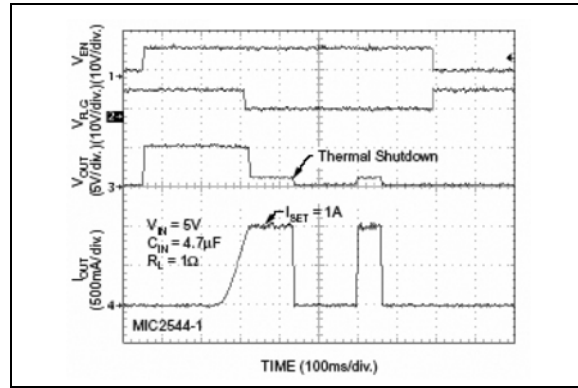
**FIGURE 2-13:** Current Limit vs. Temperature.



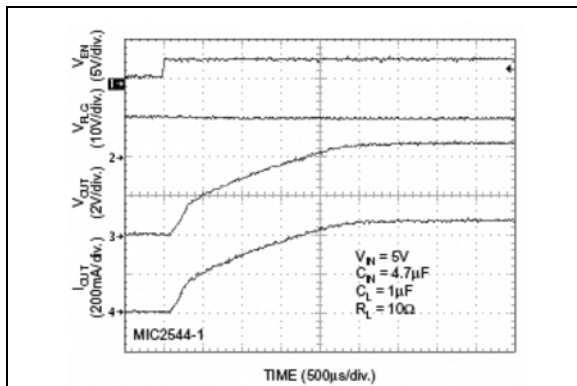
**FIGURE 2-16:** Turn-Off Response.



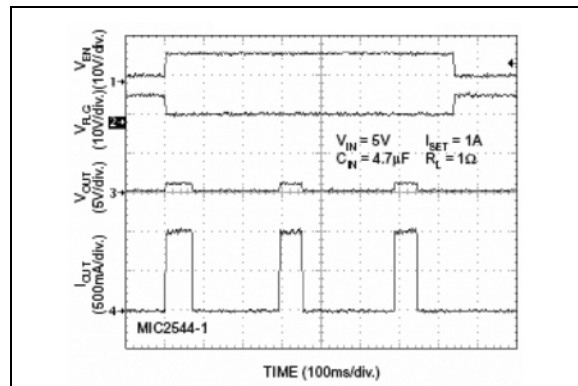
**FIGURE 2-14:** Current Limit vs. Supply Voltage.



**FIGURE 2-17:** Current-Limit Response.

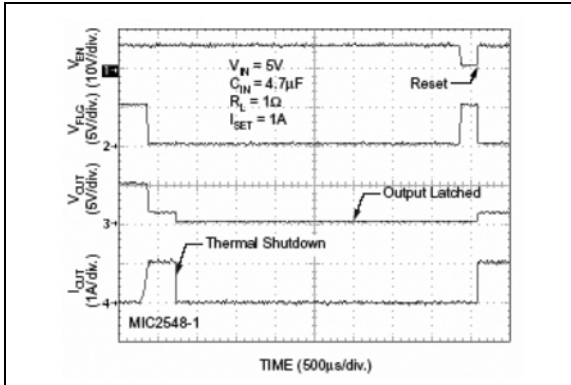


**FIGURE 2-15:** Turn-On Response.

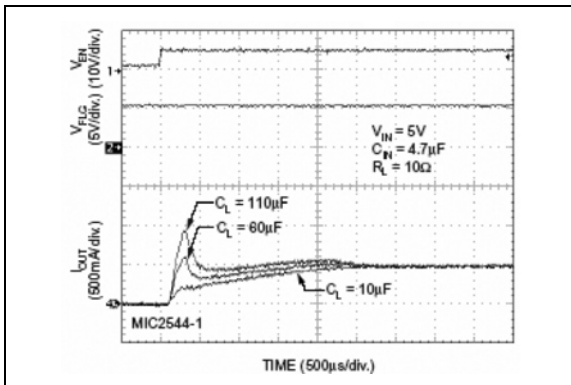


**FIGURE 2-18:** Enable Into Heavy Load.





**FIGURE 2-19:** Enable Into Heavy Load.



**FIGURE 2-20:** Inrush Current Response.

# MIC2544/48

---

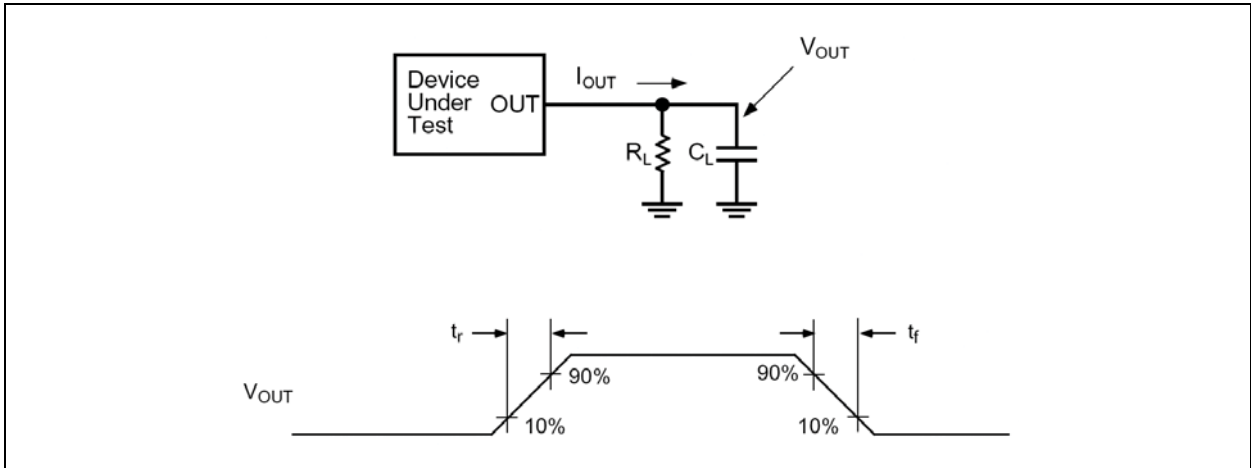
## 3.0 PIN DESCRIPTIONS

The descriptions of the pins are listed in [Table 3-1](#).

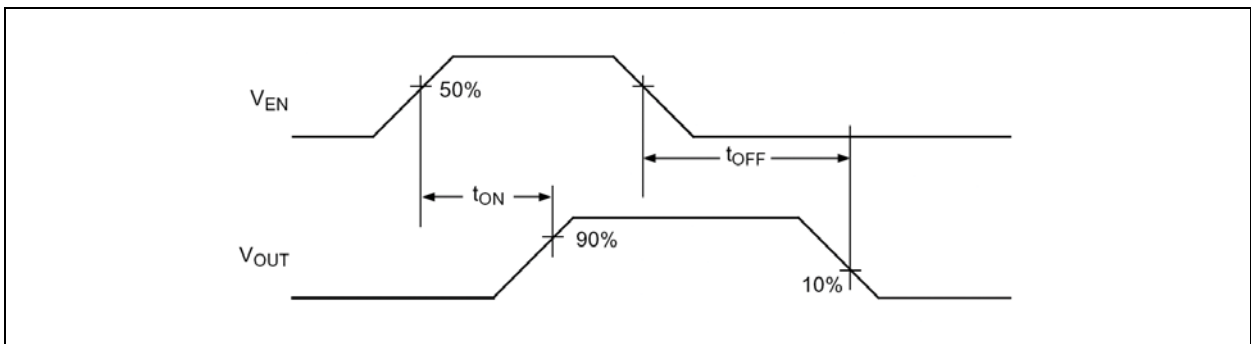
**TABLE 3-1: PIN FUNCTION TABLE**

Pin Number 8-Pin MSOP	Pin Number 8-Pin SOIC	Pin Name	Description
1	1	EN	Enable (Input): Logic-compatible enable input. Active-high (-1) or active-low (-2). High input >1.7V typical; low input <1.5V typical. Do not float. MIC2548 only: Also resets thermal shutdown latch.
2	2	FLG	Fault Flag (Output): Active-low, open-drain output. Indicates overcurrent or thermal shutdown conditions. MIC2548 only: latched low on thermal shutdown.
3	3	GND	Ground.
5	4	ILIM	Current Limit: Sets current-limit threshold using an external resistor, $R_{SET}$ , connected to ground. $154\Omega < R_{SET} < 2.29\text{ k}\Omega$ .
7	7	IN	Input: Output MOSFET drain. Also powers internal circuitry.
6, 8	6, 8	OUT	Switch (Output): Output MOSFET source. Pins 6 and 8 must be externally connected.
4	5	NC	Not internally connected.

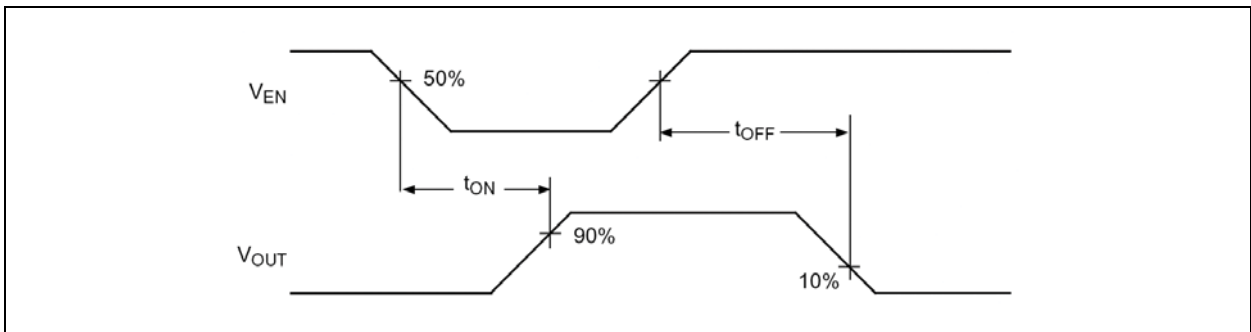
## 4.0 TEST CIRCUIT AND TIMING DIAGRAMS



**FIGURE 4-1:** Functional Characteristics Test Circuit.

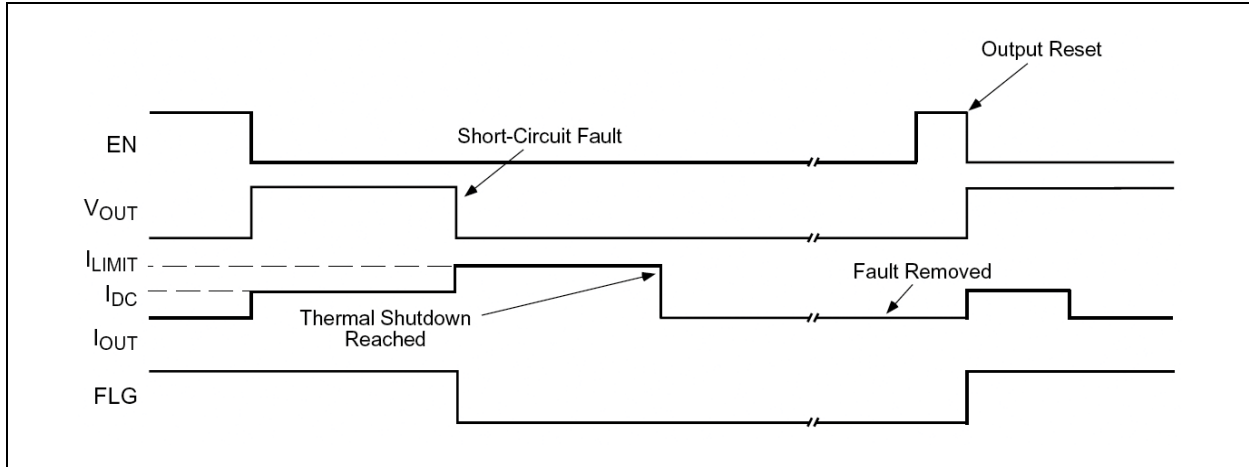


**FIGURE 4-2:** MIC2544/48-1 Timing Diagram.

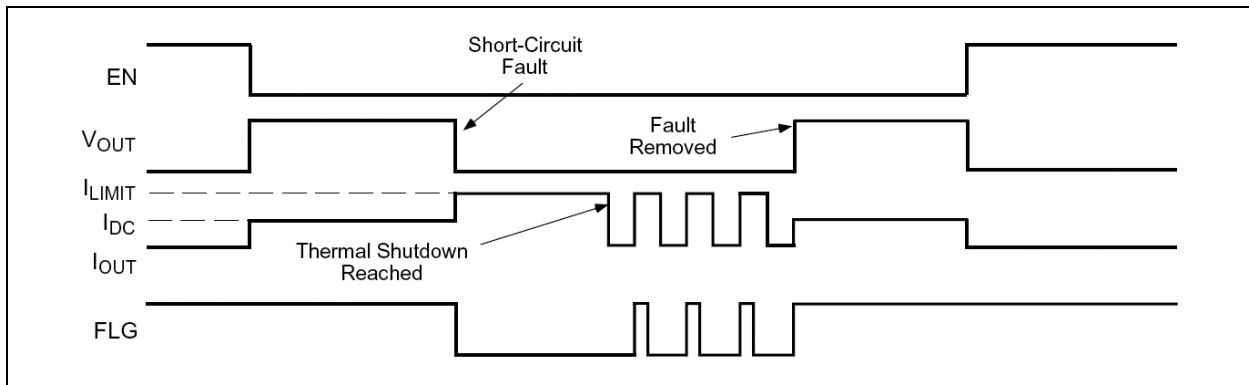


**FIGURE 4-3:** MIC2544/48-2 Timing Diagram.

# MIC2544/48



**FIGURE 4-4:** MIC2548-2 Timing: Output is Reset by Toggling EN.



**FIGURE 4-5:** MIC2544-2 Timing Diagram.

## 5.0 FUNCTIONAL DESCRIPTION

The MIC2544 and MIC2548 are high-side N-channel switches available with active-high or active-low enable inputs. Fault conditions turn-off or inhibit turn-on of the output transistor and activate the open-drain error flag transistor making it sink current to ground.

### 5.1 Input and Output

IN is the power supply connection to the logic circuitry and the drain of the output MOSFET. OUT is the source of the output MOSFET. In a typical circuit, current flows from IN to OUT toward the load. If  $V_{OUT}$  is greater than  $V_{IN}$ , current will flow from OUT to IN because the switch is bidirectional when enabled.

The output MOSFET and driver circuitry are also designed to allow the MOSFET source to be externally forced to a higher voltage than the drain ( $V_{OUT} > V_{IN}$ ) when the switch is disabled. In this situation, the MIC2544/48 avoids undesirable current flow from OUT to IN. Both OUT pins must be connected together.

### 5.2 Thermal Shutdown

Thermal shutdown shuts off the output MOSFET and signals the fault flag if the die temperature exceeds +140°C. 10°C of hysteresis prevents the switch from turning on until the die temperature drops to +130°C. Overtemperature detection functions only when the switch is enabled.

The MIC2548 features an internal latch which causes the part to remain off after thermal shutdown until a reset pulse is provided via the enable pin (pin 1). While in current-limit, the thermal shutdown latch prevents on/off cycling of the output.

Refer to [Figure 4-4](#) and [Figure 4-5](#) for timing diagrams. The flag remains low until reset.

### 5.3 Enable Input

EN must be driven logic high or logic low, or be pulled high or low for a clearly defined input. Floating the input may cause unpredictable operation. EN should not be allowed to go negative with respect to GND, and  $V_{EN}$  should be less than or equal to  $V_{IN}$ .

### 5.4 Adjustable Current-Limit

The short-circuit current-limit is user-adjustable with an external set resistor. Current-limit in the range of 100 mA to 1.5A is available with a set point accuracy of better than ±20%. The current-limit circuit prevents damage to the output MOSFET and external load.

The nominal current-limit value is set with an external resistor between ILIM and GND. For a desired current-limit, the value of the external set resistor is given by:

#### EQUATION 5-1:

$$R_{SET} = \frac{230V}{I_{LIMIT}}$$

Where:

$$154\Omega < R_{SET} < 2.29 \text{ k}\Omega$$

For example, to set a 1A nominal current-limit,  $R_{SET}$  is calculated as:

#### EQUATION 5-2:

$$\frac{230V}{1A} = 230\Omega$$

Current through  $R_{SET}$  increases with OUT current. The voltage across  $R_{SET}$  could be monitored with a high impedance comparator to provide an indication of output current.  $R_{SET}$  should be between  $154\Omega \pm 0.5\%$  and  $2.29 \text{ k}\Omega \pm 0.5\%$ .

### 5.5 Short-Circuit Protection

In the event of a short circuit, the output current will fold back to approximately 80% of the short-circuit current-limit.

### 5.6 Fault Flag

FLG is an N-channel, open-drain MOSFET output. The fault flag is active (low) for current-limit or thermal shutdown conditions. The flag output MOSFET is capable of sinking a 10 mA load to typically 100 mV above ground.

# MIC2544/48

## 6.0 APPLICATION INFORMATION

### 6.1 Supply Filtering

A 0.1  $\mu\text{F}$  to 1  $\mu\text{F}$  bypass capacitor from IN to GND, located near the MIC2544 and MIC2548, is strongly recommended to control supply transients. Without a bypass capacitor, an output short may cause sufficient ringing on the input (from supply lead inductance) to damage internal control circuitry.

Input transients must not exceed the absolute maximum supply voltage ( $V_{\text{IN(ABS\_MAX)}} = 7\text{V}$ ) even for a short duration.

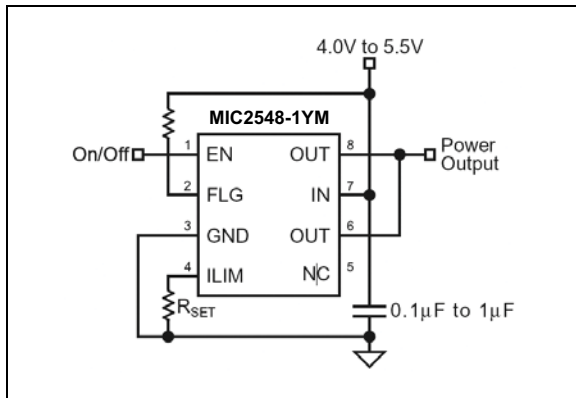


FIGURE 6-1: Supply Bypassing.

### 6.2 Power Dissipation

The device's junction temperature depends on several factors such as the load, PCB layout, ambient temperature, and package type. Equations that can be used to calculate power dissipation and junction temperature are found below.

Calculation of power dissipation can be accomplished by the following equation:

#### EQUATION 6-1:

$$PD = R_{DS(ON)} \times (I_{OUT})^2$$

To relate this to junction temperature, use the following equation:

#### EQUATION 6-2:

$$T_J = P_D \times \theta_{JA} + T_A$$

Where:

$T_J$	Junction temperature
$T_A$	Ambient temperature
$\theta_{JA}$	Thermal resistance of the package

### 6.3 Transient Overcurrent Filter

The inrush current from the connection of a heavy capacitive load may cause the fault flag to fall for 10  $\mu\text{s}$  to 200  $\mu\text{s}$  while the switch is in a constant-current mode, charging the capacitance.

Adding an optional series resistor-capacitor ( $R_{SET2}$ ) in parallel with  $R_{SET}$ , as shown in Figure 6-2, allows the transient current-limit to be set to a different value than steady state. A typical USB hot-plug inrush is 2A to 3A for 10  $\mu\text{s}$  to 20  $\mu\text{s}$ . If  $R_{SET}$  is 435 $\Omega$  (510 mA), an  $R_{SET2}$  of 88 $\Omega$  (2.5A) and  $C_{SET}$  of 1  $\mu\text{F}$  ( $R_C = 100 \mu\text{s}$ ) allows transient surge of 3A to pass for 100  $\mu\text{s}$  without tripping the overcurrent flag (FLG).

### 6.4 USB Power Distribution

The MIC2544 is ideal for meeting USB power distribution requirements. Figure 6-2 depicts a USB Host application.  $R_{SET}$  should be set to a value providing a current-limit greater than 500 mA.

The accurate current-limit of the MIC2544 will reduce power supply current requirements. Also, fast reaction to short-circuit faults prevent voltage droop in mobile PC applications.

### 6.5 Printed Circuit Board Hot-Plug

The MIC2544/48 are ideal inrush current-limiters suitable for hot-plug applications. Due to the integrated charge pump, the MIC2544/48 presents a high impedance when off and slowly becomes a low impedance as it turns on.

This soft-start feature effectively isolates power supplies from highly capacitive loads by reducing inrush current during hot-plug events. Figure 6-3 shows how the MIC2544 may be used in a hot-plug application.



# MIC2544/48

## 7.0 PACKAGING INFORMATION

### 7.1 Package Marking Information

SOIC-8\*

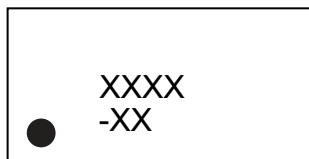


Example

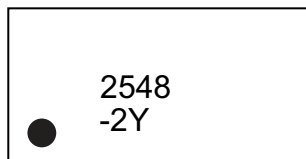


Note: The "A" in line 3 of the SOIC package appears only on MIC2544.

MSOP-8\*



Example



<b>Legend:</b>	XX...X	Product code or customer-specific information
	Y	Year code (last digit of calendar year)
	YY	Year code (last 2 digits of calendar year)
	WW	Week code (week of January 1 is week '01')
	NNN	Alphanumeric traceability code
	(e3)	Pb-free JEDEC® designator for Matte Tin (Sn)
	*	This package is Pb-free. The Pb-free JEDEC designator ((e3)) can be found on the outer packaging for this package.
	•, ▲, ▼	Pin one index is identified by a dot, delta up, or delta down (triangle mark).
<b>Note:</b>	In the event the full Microchip part number cannot be marked on one line, it will be carried over to the next line, thus limiting the number of available characters for customer-specific information. Package may or may not include the corporate logo.	
	Underbar ( ¯ ) and/or Overbar ( ¯ ) symbol may not be to scale.	

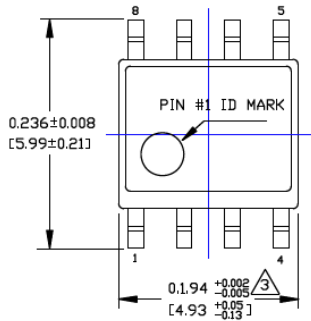


## 8-Lead SOIC Package Outline and Recommended Land Pattern

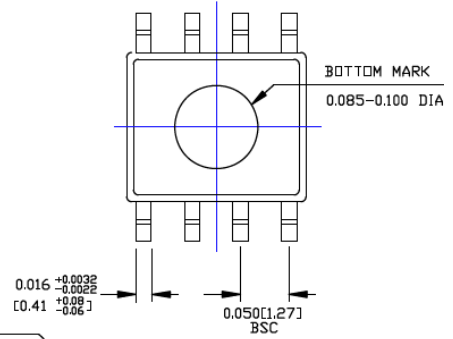
**TITLE**

8 LEAD SOICN PACKAGE OUTLINE & RECOMMENDED LAND PATTERN

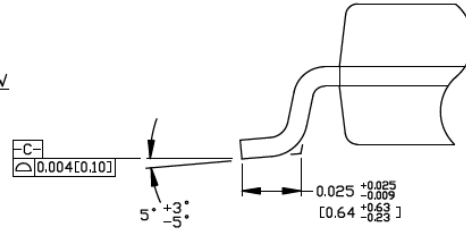
DRAWING #	SOICN-8LD-PL-1	UNIT	INCH [MM]
-----------	----------------	------	-----------



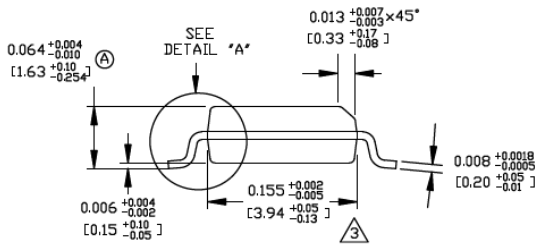
TOP VIEW



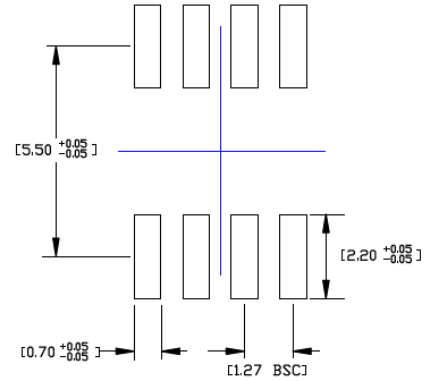
BOTTOM VIEW



DETAIL "A"



END VIEW



RECOMMENDED LAND PATTERN

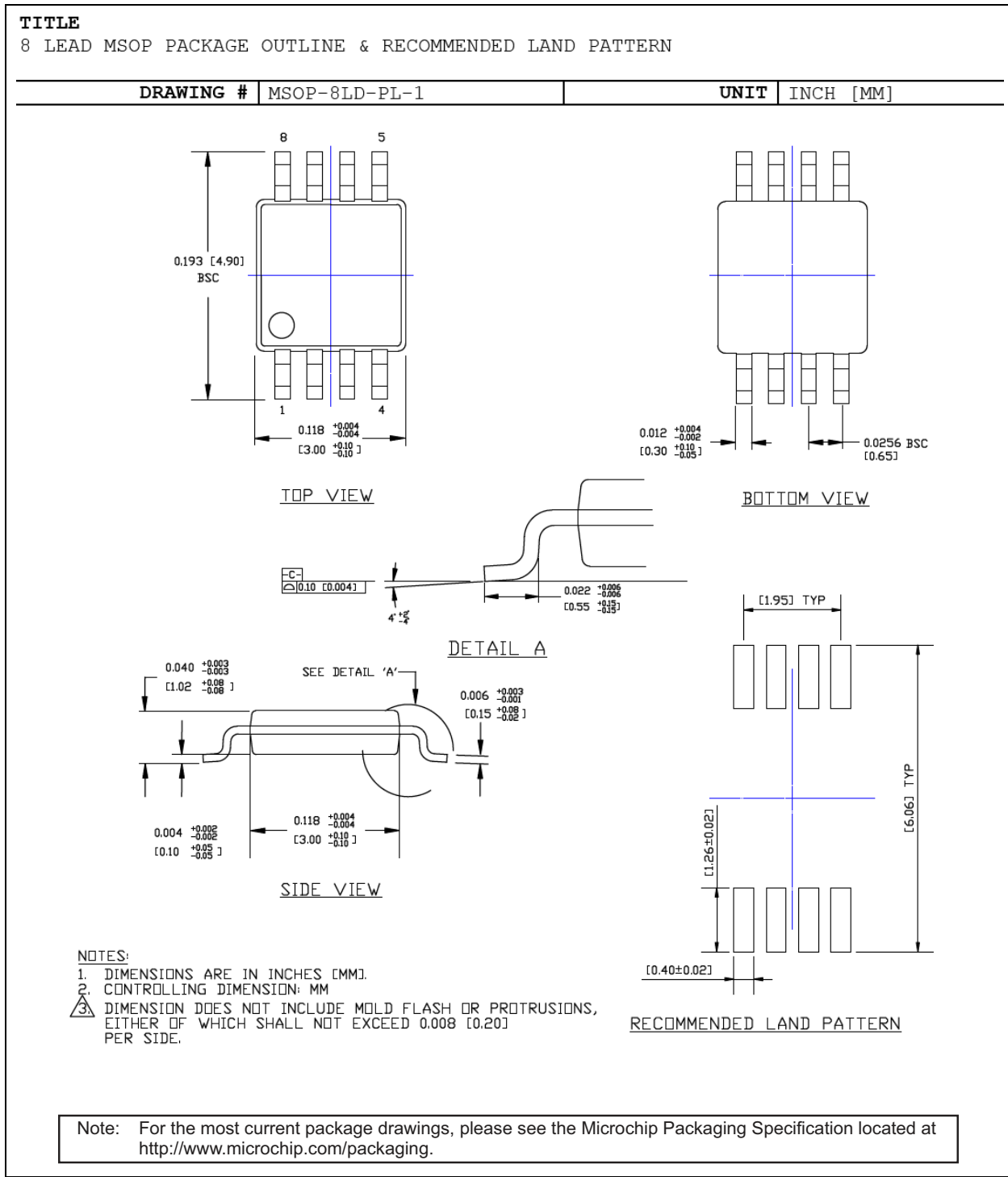
**NOTES:**

1. DIMENSIONS ARE IN INCHES[MM].
2. CONTROLLING DIMENSION: INCHES.
3. DIMENSION DOES NOT INCLUDE MOLD FLASH OR PROTRUSIONS, EITHER OF WHICH SHALL NOT EXCEED 0.010[0.25] PER SIDE.

Note: For the most current package drawings, please see the Microchip Packaging Specification located at <http://www.microchip.com/packaging>.

# MIC2544/48

## 8-Lead MSOP Package Outline and Recommended Land Pattern



## APPENDIX A: REVISION HISTORY

### Revision B (June 2017)

- Minor text changes in the [Product Identification System](#) section.

### Revision A (March 2017)

- Converted Micrel document MIC2544/48 to Microchip data sheet DS20005725B.
- Minor text changes throughout.
- Updated absolute maximum Output Voltage values in [Absolute Maximum Ratings †](#) section and [Application Information](#) section.
- Removed all references to discontinued leaded parts (B-designated parts).

# MIC2544/48

---

NOTES:

## PRODUCT IDENTIFICATION SYSTEM

To order or obtain information, e.g., on pricing or delivery, contact your local Microchip representative or sales office.

<u>PART NO.</u>	-	<u>X</u>	<u>X</u>	<u>X</u>	-	<u>XX</u>
Device		Enable	Temperature	Package		Media Type
<b>Device:</b>		MIC2544:	Programmable Current-Limit High-Side Switch			
		MIC2548:	Programmable Current-Limit High-Side Switch with Thermal Shutdown Latch			
<b>Enable:</b>		1	= Active-High			
		2	= Active-Low			
<b>Temperature:</b>		Y	= -40°C to +125°C			
<b>Package:</b>		M	= 8-Lead SOIC			
		MM	= 8-Lead MSOP			
<b>Media Type:</b>		TR	= 2,500/Reel			
		(blank)	= 95/Tube (SOIC)			
		(blank)	= 100/Tube (MSOP)			

<b>Examples:</b>	
a) MIC2544-1YM:	Programmable Current-Limit High-Side Switch, Active-High, -40°C to +125°C Temp. Range, 8-Lead SOIC, 95/Tube
b) MIC2544-1YM-TR:	Programmable Current-Limit High-Side Switch, Active-High, -40°C to +125°C Temp. Range, 8-Lead SOIC, 2,500/Reel
c) MIC2544-2YM:	Programmable Current-Limit High-Side Switch, Active-Low, -40°C to +125°C Temp. Range, 8-Lead SOIC, 95/Tube
d) MIC2544-2YM-TR:	Programmable Current-Limit High-Side Switch, Active-Low, -40°C to +125°C Temp. Range, 8-Lead SOIC, 2,500/Reel
e) MIC2548-1YM:	Programmable Current-Limit High-Side Switch, Thermal Shutdown Latch, Active-High, -40°C to +125°C Temp. Range, 8-Lead SOIC, 100/Tube
f) MIC2548-1YM-TR:	Programmable Current-Limit High-Side Switch, Thermal Shutdown Latch, Active-High, -40°C to +125°C Temp. Range, 8-Lead SOIC, 2,500/Reel
g) MIC2548-2YM:	Programmable Current-Limit High-Side Switch, Thermal Shutdown Latch, Active-Low, -40°C to +125°C Temp. Range, 8-Lead SOIC, 100/Tube
h) MIC2548-2YM-TR:	Programmable Current-Limit High-Side Switch, Thermal Shutdown Latch, Active-Low, -40°C to +125°C Temp. Range, 8-Lead SOIC, 2,500/Reel

**Note 1:** Tape and Reel identifier only appears in the catalog part number description. This identifier is used for ordering purposes and is not printed on the device package. Check with your Microchip Sales Office for package availability with the Tape and Reel option.

# MIC2544/48

---

NOTES:

---

---

**Note the following details of the code protection feature on Microchip devices:**

- Microchip products meet the specification contained in their particular Microchip Data Sheet.
- Microchip believes that its family of products is one of the most secure families of its kind on the market today, when used in the intended manner and under normal conditions.
- There are dishonest and possibly illegal methods used to breach the code protection feature. All of these methods, to our knowledge, require using the Microchip products in a manner outside the operating specifications contained in Microchip's Data Sheets. Most likely, the person doing so is engaged in theft of intellectual property.
- Microchip is willing to work with the customer who is concerned about the integrity of their code.
- Neither Microchip nor any other semiconductor manufacturer can guarantee the security of their code. Code protection does not mean that we are guaranteeing the product as “unbreakable.”

Code protection is constantly evolving. We at Microchip are committed to continuously improving the code protection features of our products. Attempts to break Microchip's code protection feature may be a violation of the Digital Millennium Copyright Act. If such acts allow unauthorized access to your software or other copyrighted work, you may have a right to sue for relief under that Act.

---

Information contained in this publication regarding device applications and the like is provided only for your convenience and may be superseded by updates. It is your responsibility to ensure that your application meets with your specifications. MICROCHIP MAKES NO REPRESENTATIONS OR WARRANTIES OF ANY KIND WHETHER EXPRESS OR IMPLIED, WRITTEN OR ORAL, STATUTORY OR OTHERWISE, RELATED TO THE INFORMATION, INCLUDING BUT NOT LIMITED TO ITS CONDITION, QUALITY, PERFORMANCE, MERCHANTABILITY OR FITNESS FOR PURPOSE. Microchip disclaims all liability arising from this information and its use. Use of Microchip devices in life support and/or safety applications is entirely at the buyer's risk, and the buyer agrees to defend, indemnify and hold harmless Microchip from any and all damages, claims, suits, or expenses resulting from such use. No licenses are conveyed, implicitly or otherwise, under any Microchip intellectual property rights unless otherwise stated.

*Microchip received ISO/TS-16949:2009 certification for its worldwide headquarters, design and wafer fabrication facilities in Chandler and Tempe, Arizona; Gresham, Oregon and design centers in California and India. The Company's quality system processes and procedures are for its PIC® MCUs and dsPIC® DSCs, KEELoC® code hopping devices, Serial EEPROMs, microperipherals, nonvolatile memory and analog products. In addition, Microchip's quality system for the design and manufacture of development systems is ISO 9001:2000 certified.*

**QUALITY MANAGEMENT SYSTEM  
CERTIFIED BY DNV  
= ISO/TS 16949 =**

### Trademarks

The Microchip name and logo, the Microchip logo, AnyRate, AVR, AVR logo, AVR Freaks, BeaconThings, BitCloud, CryptoMemory, CryptoRF, dsPIC, FlashFlex, flexPWR, Heldo, JukeBlox, KEELoC, KEELoC logo, Klear, LANCheck, LINK MD, maXStylus, maXTouch, MediaLB, megaAVR, MOST, MOST logo, MPLAB, OptoLyzer, PIC, picoPower, PICSTART, PIC32 logo, Prochip Designer, QTouch, RightTouch, SAM-BA, SpyNIC, SST, SST Logo, SuperFlash, tinyAVR, UNI/O, and XMEGA are registered trademarks of Microchip Technology Incorporated in the U.S.A. and other countries.

ClockWorks, The Embedded Control Solutions Company, EtherSynch, Hyper Speed Control, HyperLight Load, IntelliMOS, mTouch, Precision Edge, and Quiet-Wire are registered trademarks of Microchip Technology Incorporated in the U.S.A.

Adjacent Key Suppression, AKS, Analog-for-the-Digital Age, Any Capacitor, AnyIn, AnyOut, BodyCom, chipKIT, chipKIT logo, CodeGuard, CryptoAuthentication, CryptoCompanion, CryptoController, dsPICDEM, dsPICDEM.net, Dynamic Average Matching, DAM, ECAN, EtherGREEN, In-Circuit Serial Programming, ICSP, Inter-Chip Connectivity, JitterBlocker, KlearNet, KlearNet logo, Mindi, MiWi, motorBench, MPASM, MPF, MPLAB Certified logo, MPLIB, MPLINK, MultiTRAK, NetDetach, Omniscient Code Generation, PICDEM, PICDEM.net, PICKit, PICTail, PureSilicon, QMatrix, RightTouch logo, REAL ICE, Ripple Blocker, SAM-ICE, Serial Quad I/O, SMART-I.S., SQI, SuperSwitcher, SuperSwitcher II, Total Endurance, TSHARC, USBCheck, VariSense, ViewSpan, WiperLock, Wireless DNA, and ZENA are trademarks of Microchip Technology Incorporated in the U.S.A. and other countries.

SQTP is a service mark of Microchip Technology Incorporated in the U.S.A.

Silicon Storage Technology is a registered trademark of Microchip Technology Inc. in other countries.

GestIC is a registered trademark of Microchip Technology Germany II GmbH & Co. KG, a subsidiary of Microchip Technology Inc., in other countries.

All other trademarks mentioned herein are property of their respective companies.

© 2017, Microchip Technology Incorporated, All Rights Reserved.  
ISBN: 978-1-5224-1794-1



# MICROCHIP

## Worldwide Sales and Service

### AMERICAS

**Corporate Office**  
2355 West Chandler Blvd.  
Chandler, AZ 85224-6199  
Tel: 480-792-7200  
Fax: 480-792-7277  
Technical Support:  
<http://www.microchip.com/support>  
Web Address:  
[www.microchip.com](http://www.microchip.com)

**Atlanta**  
Duluth, GA  
Tel: 678-957-9614  
Fax: 678-957-1455

**Austin, TX**  
Tel: 512-257-3370

**Boston**  
Westborough, MA  
Tel: 774-760-0087  
Fax: 774-760-0088

**Chicago**  
Itasca, IL  
Tel: 630-285-0071  
Fax: 630-285-0075

**Dallas**  
Addison, TX  
Tel: 972-818-7423  
Fax: 972-818-2924

**Detroit**  
Novi, MI  
Tel: 248-848-4000

**Houston, TX**  
Tel: 281-894-5983

**Indianapolis**  
Noblesville, IN  
Tel: 317-773-8323  
Fax: 317-773-5453  
Tel: 317-536-2380

**Los Angeles**  
Mission Viejo, CA  
Tel: 949-462-9523  
Fax: 949-462-9608  
Tel: 951-273-7800

**Raleigh, NC**  
Tel: 919-844-7510

**New York, NY**  
Tel: 631-435-6000

**San Jose, CA**  
Tel: 408-735-9110  
Tel: 408-436-4270

**Canada - Toronto**  
Tel: 905-695-1980  
Fax: 905-695-2078

### ASIA/PACIFIC

**Asia Pacific Office**  
Suites 3707-14, 37th Floor  
Tower 6, The Gateway  
Harbour City, Kowloon

**Hong Kong**  
Tel: 852-2943-5100  
Fax: 852-2401-3431

**Australia - Sydney**  
Tel: 61-2-9868-6733  
Fax: 61-2-9868-6755

**China - Beijing**  
Tel: 86-10-8569-7000  
Fax: 86-10-8528-2104

**China - Chengdu**  
Tel: 86-28-8665-5511  
Fax: 86-28-8665-7889

**China - Chongqing**  
Tel: 86-23-8980-9588  
Fax: 86-23-8980-9500

**China - Dongguan**  
Tel: 86-769-8702-9880

**China - Guangzhou**  
Tel: 86-20-8755-8029

**China - Hangzhou**  
Tel: 86-571-8792-8115  
Fax: 86-571-8792-8116

**China - Hong Kong SAR**  
Tel: 852-2943-5100  
Fax: 852-2401-3431

**China - Nanjing**  
Tel: 86-25-8473-2460  
Fax: 86-25-8473-2470

**China - Qingdao**  
Tel: 86-532-8502-7355  
Fax: 86-532-8502-7205

**China - Shanghai**  
Tel: 86-21-3326-8000  
Fax: 86-21-3326-8021

**China - Shenyang**  
Tel: 86-24-2334-2829  
Fax: 86-24-2334-2393

**China - Shenzhen**  
Tel: 86-755-8864-2200  
Fax: 86-755-8203-1760

**China - Wuhan**  
Tel: 86-27-5980-5300  
Fax: 86-27-5980-5118

**China - Xian**  
Tel: 86-29-8833-7252  
Fax: 86-29-8833-7256

### ASIA/PACIFIC

**China - Xiamen**  
Tel: 86-592-2388138  
Fax: 86-592-2388130

**China - Zhuhai**  
Tel: 86-756-3210040  
Fax: 86-756-3210049

**India - Bangalore**  
Tel: 91-80-3090-4444  
Fax: 91-80-3090-4123

**India - New Delhi**  
Tel: 91-11-4160-8631  
Fax: 91-11-4160-8632

**India - Pune**  
Tel: 91-20-3019-1500

**Japan - Osaka**  
Tel: 81-6-6152-7160  
Fax: 81-6-6152-9310

**Japan - Tokyo**  
Tel: 81-3-6880-3770  
Fax: 81-3-6880-3771

**Korea - Daegu**  
Tel: 82-53-744-4301  
Fax: 82-53-744-4302

**Korea - Seoul**  
Tel: 82-2-554-7200  
Fax: 82-2-558-5932 or  
82-2-558-5934

**Malaysia - Kuala Lumpur**  
Tel: 60-3-6201-9857  
Fax: 60-3-6201-9859

**Malaysia - Penang**  
Tel: 60-4-227-8870  
Fax: 60-4-227-4068

**Philippines - Manila**  
Tel: 63-2-634-9065  
Fax: 63-2-634-9069

**Singapore**  
Tel: 65-6334-8870  
Fax: 65-6334-8850

**Taiwan - Hsin Chu**  
Tel: 886-3-5778-366  
Fax: 886-3-5770-955

**Taiwan - Kaohsiung**  
Tel: 886-7-213-7830

**Taiwan - Taipei**  
Tel: 886-2-2508-8600  
Fax: 886-2-2508-0102

**Thailand - Bangkok**  
Tel: 66-2-694-1351  
Fax: 66-2-694-1350

### EUROPE

**Austria - Wels**  
Tel: 43-7242-2244-39  
Fax: 43-7242-2244-393

**Denmark - Copenhagen**  
Tel: 45-4450-2828  
Fax: 45-4485-2829

**Finland - Espoo**  
Tel: 358-9-4520-820

**France - Paris**  
Tel: 33-1-69-53-63-20  
Fax: 33-1-69-30-90-79

**France - Saint Cloud**  
Tel: 33-1-30-60-70-00

**Germany - Garching**  
Tel: 49-8931-9700

**Germany - Haan**  
Tel: 49-2129-3766400

**Germany - Heilbronn**  
Tel: 49-7131-67-3636

**Germany - Karlsruhe**  
Tel: 49-721-625370

**Germany - Munich**  
Tel: 49-89-627-144-0  
Fax: 49-89-627-144-44

**Germany - Rosenheim**  
Tel: 49-8031-354-560

**Israel - Ra'anana**  
Tel: 972-9-744-7705

**Italy - Milan**  
Tel: 39-0331-742611  
Fax: 39-0331-466781

**Italy - Padova**  
Tel: 39-049-7625286

**Netherlands - Drunen**  
Tel: 31-416-690399  
Fax: 31-416-690340

**Norway - Trondheim**  
Tel: 47-7289-7561

**Poland - Warsaw**  
Tel: 48-22-3325737

**Romania - Bucharest**  
Tel: 40-21-407-87-50

**Spain - Madrid**  
Tel: 34-91-708-08-90  
Fax: 34-91-708-08-91

**Sweden - Gothenberg**  
Tel: 46-31-704-60-40

**Sweden - Stockholm**  
Tel: 46-8-5090-4654

**UK - Wokingham**  
Tel: 44-118-921-5800  
Fax: 44-118-921-5820