

Switching Power Supply Type SPD 240W Compact DIN rail mounting



- Universal AC input full range
- Installation on DIN rail 7.5 or 15mm
- Short circuit protection
- Active PFC as standard
- High efficiency up to 93%
- Power ready output
- LED indicator for DC power ON
- LED indicator for DC low
- Parallel connection feature
- Compact dimensions
- UL, cUL listed and TUV/CE approved
- 150% peak load capability

Product Description

The Switching power supplies SPD series are specially designed to be used in all automation application where the installation is on a DIN rail and compact dimensions and performance are a must.

Ordering Key

SP D 24 240 1C X

Model _____
 Mounting (D = Din rail) _____
 Output voltage _____
 Output power _____
 Input type _____
 Optional features _____

Input type: 1C = single phase Compact version

Approvals



Optional features

Description	Code
Screw terminal	Nil
Plug-in connectors	B

Output Performance

MODEL NO.	INPUT VOLTAGE	OUTPUT POWER	OUTPUT VOLTAGE	OUTPUT CURRENT	EFF. (min.)	EFF. (typ.)
Single Output Models						
SPD 12 240 1C X	88~264 VAC	192 WATTS	+12 VDC	16A	89%	91%
SPD 24 240 1C X	88~264 VAC	240 WATTS	+ 24 VDC	10A	91%	93%

Output Data (All specifications are at nominal values, full load, 25°C unless otherwise noticed)

Line regulation	± 1%	Rated continuous loading 12V Model 24V Model	16A@12VDC/13A@14.5VDC 10A@24VDC/8.4A@28.5VDC	
Load regulation	±1%			
Minimum load	0%	Reverse voltage	18VDC 35VDC	
Turn on time Vi nom, Io nom	1000ms (full resistive load) 1500ms with 7000µF CAP	Capacitor load	7000µF	
Transient recovery time	2ms	Temperature coefficient	±0.03°C	
Ripple and noise	100mVpp	DC ON indicator threshold at start up (Green LED)	VDC Min. Max.	
Output voltage accuracy	0% ÷ +1%	Vi nom, Io nom 12V Model	10	11.2
Hold up time Vi= 115VAC Vi= 230VAC	25ms 30ms	24V Model	17.6	19.4
Voltage fall time (I _o nom, Vi nom)	150ms	DC LOW indicator threshold at start up (Red LED)	VDC Min. Max.	
Voltage rise time Vi nom, Io nom	150ms (full resistive load) 500ms with 7000µF CAP	Vi nom, Io nom 12V Model	10	11.2
Voltage trim range 12V Model 24V Model	11.4-14.5 VDC 22.5-28.5 VDC	24V Model	17.6	19.4
		Parallel operation	0.1 Io min~0.9 Io max	

Input Data (All specifications are at nominal values, full load, 25°C unless otherwise noticed)

Rated input voltage I_{nom}	100 - 240VAC	Power dissipation (V_i : 230VAC, I_o nom)	12V Model 24V Model	17W 16W
Voltage range		Frequency range	47- 63Hz	
AC IN	88 - 264VAC	Leakage current	Input-Output	<0.25mA
DC IN	120 - 375VDC		Input-FG	<3.5mA
Rated input current		P.F.C. (Active)	0.97@ V_i :230VAC, I_o nom	
V_i: 88VAC I_o nom	3.2A Max.			
V_i: 115VAC I_o nom	2.3A Typ.			
V_i: 230VAC I_o nom	1.15A Typ.			
Inrush current				
V_i= 115VAC	24A			
V_i= 230VAC	48A			

Controls and Protections (All specifications are at nominal values, full load, 25°C unless otherwise noticed)

Overload V_i nom (see typ current limited curve)	120% - 150%	Power RDY (for 24V model only)	Threshold voltage of contact closed (at start up)
Input fuse	T5A/250VAC internal ¹⁾	Electrical isolation	500VDC
Output short circuit	Shut-down protection, after 7s auto-restart	Over temperature Detect on heat sink, shut down O/P voltage, recovers automatically after temperature goes down	100 - 110°C
Over voltage protection (Shut-Down Protection)	VDC	Rated over load protection	120 - 150%
	Min.	Max.	
12V Model	14.5	17.5	
24V Model	30	33	
Internal surge voltage protection IEC 61000-4-5	Varistor	V_i nom (see typ current limited curve)	

¹⁾ Fuse not replaceable by user

General Data (All specifications are at nominal values, full load, 25°C unless otherwise noticed)

Ambient temperature	-40°C to + 71°C	Pollution degree	2
Derating (+61°C to + 71°C)	2.5%/°C (see curve)	MTBF (Bellcore issue 6 @ 40°C, GB)	
Relative humidity	20 ~ 95%RH	12V Model	374000 Hours
Storage temperature	-40°C to +85°C	24V Model	384000 Hours
Protection degree	IP20	Case material	Metal
Cooling	Free air convection	Altitude	4850m
Insulation voltage		Dimensions LxWxD mm(inch)	
Input-Output	3000VAC/4242VDC min	Screw terminal type	124.5(4.9)x64(2.52)x123.6(4.87)
Input-Fg	1500VAC/2121VDC min	Detachable connector type	143.5(5.65)x64(2.52)x123.6(4.87)
Insulation resistance I/O	100M Ω min (@ 500VDC)	Weight	860g
Switching Frequency	90 Khz Typ	Packing	960g

Norms and Standards

Vibration resistance	meet IEC 60068-2-6 (Mounting by rail: Random wave, 10-500 Hz, 2G each long Z, Y, Z axes 10 min/cycle, 60min.)	CE	EN 61000-6-3, EN 55022 Class B, EN 61000-3-2, EN 61000-3-3, EN 61000-6-2, EN 55024, EN 61000-4-2 level 4, EN 61000-4-3 level 3 EN 61000-4-4 level 4 EN 61000-4-5 L-N level 3 EN 61000-4-6 level 3 EN 61000-4-8 level 4 EN 61000-4-11, ENV 50204 Level 2 EN 61204-3
Shock resistance	meet IEC 60068-2-27 (4G, 22ms, 3 Axis, 6 faces, 3 times for each face)		
UL/cUL	UL 508 Listed UL 60950-1 Recognized		
TUV	EN 60950-1. CB scheme		

Block Diagram

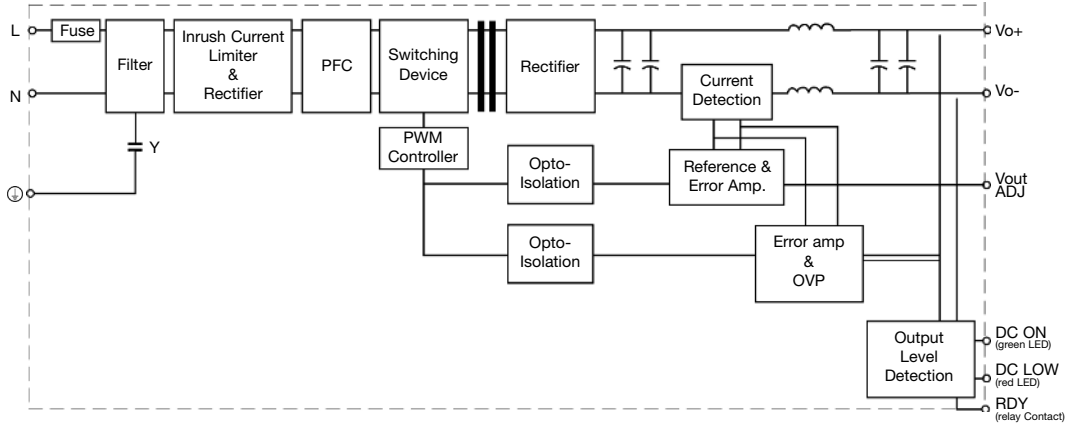

Pin Assignment and Front Controls

Pin No.	Designation	Description
1	RDY	A normal open relay contact for DC ON level control Never connect except 24V model
2		
3. 4	V+	Positive output terminal
5. 6	V-	Negative output terminal
7	⊥	Ground this terminal to minimize high-frequency emissions
8	N	Input terminals (neutral conductor, no polarity at DC input)
9	L	Input terminal (phase conductor, no polarity at DC input)
LED	DC ON	Operation indicator LED
LED	DC LO	DC LOW voltage indicator LED
Trimmer	Vout ADJ.	Trimmer-potentiometer for Vout adjustment
Switch	S/P	Single / Parallel select switch

Derating Curve

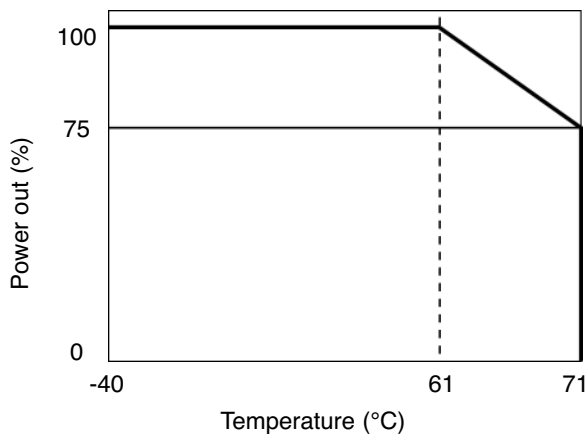

Typ. Efficiency curve

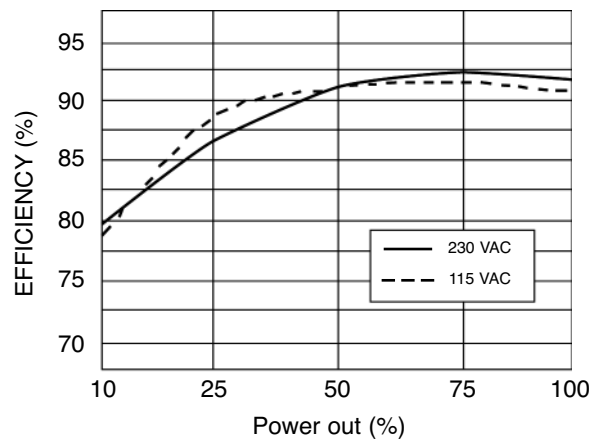

Typ. Current Limited Curve

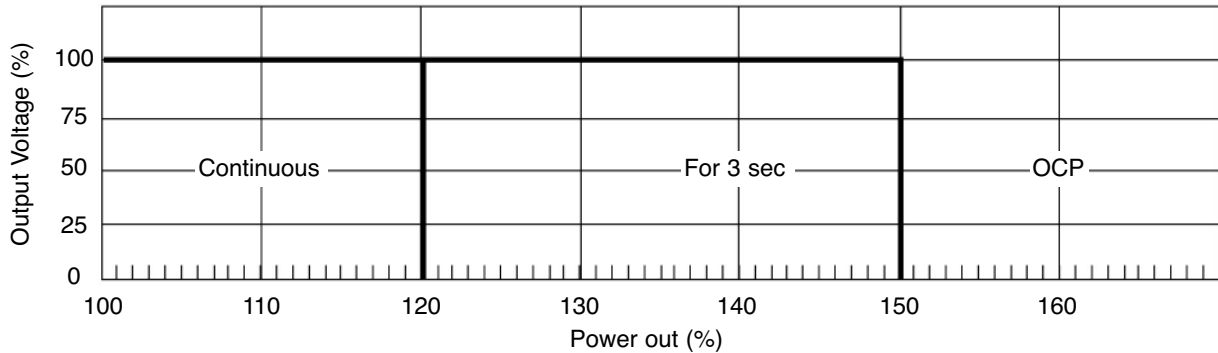

Peak Loading

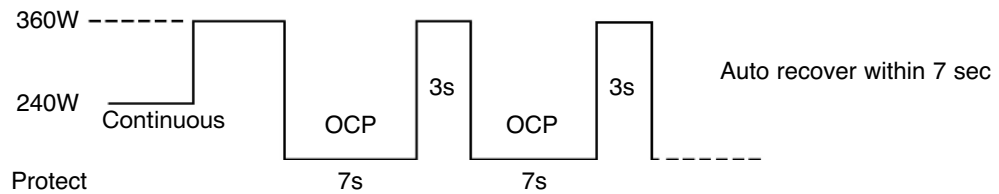

Mechanical Drawings mm (inches)

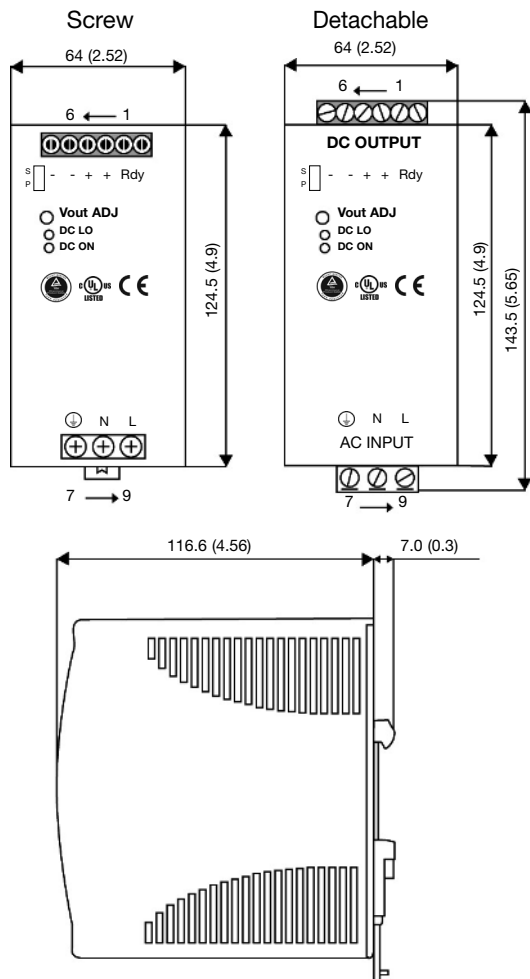

Installation

Ventilation and cooling

Normal convection.
 All sides 25mm free space
 for cooling is recommended

Connector size range

Screw terminals:

- Input Terminals
- Output Terminals

AWG24-10 (0.2~4mm²)
 flexible / solid cable,
 max. torque at 1.16Nm
 (9 pound-inches).
 max. torque at 0.616Nm
 (5.5 pound-inches).
 8mm stripping at cable end
 recommends.

Detachable connectors:

- Input Terminals
- Output Terminals

AWG24-12 (0.2~2.5 mm²)
 flexible / solid cable,
 max. torque at 0.51 Nm
 (4.5 pound-inches).
 max. torque at 0.79 Nm
 (7 pound-inches).
 4~5mm stripping at cable
 end recommends.

Use copper conductors
 only, 60/75°C.