

SSTUA32866

1.8 V 25-bit 1 : 1 or 14-bit 1 : 2 configurable registered buffer with parity for DDR2-667 RDIMM applications

Rev. 02 — 26 March 2007

Product data sheet

1. General description

The SSTUA32866 is a 1.8 V configurable register specifically designed for use on DDR2 memory modules requiring a parity checking function. It is defined in accordance with the JEDEC standard for the SSTUA32866 registered buffer. The register is configurable (using configuration pins C0 and C1) to two topologies: 25-bit 1 : 1 or 14-bit 1 : 2, and in the latter configuration can be designated as Register A or Register B on the DIMM.

The SSTUA32866 accepts a parity bit from the memory controller on its parity bit (PAR_IN) input, compares it with the data received on the DIMM-independent D-inputs and indicates whether a parity error has occurred on its open-drain \overline{QERR} pin (active LOW). The convention is even parity, that is, valid parity is defined as an even number of ones across the DIMM-independent data inputs combined with the parity input bit.

The SSTUA32866 is packaged in a 96-ball, 6 × 16 grid, 0.8 mm ball pitch LFBGA package (13.5 mm × 5.5 mm).

2. Features

- Configurable register supporting DDR2 up to 667 MT/s Registered DIMM applications
- Configurable to 25-bit 1 : 1 mode or 14-bit 1 : 2 mode
- Controlled output impedance drivers enable optimal signal integrity and speed
- Exceeds JESD82-7 speed performance (1.8 ns max. single-bit switching propagation delay; 2.0 ns max. mass-switching)
- Supports up to 450 MHz clock frequency of operation
- Optimized pinout for high-density DDR2 module design
- Chip-selects minimize power consumption by gating data outputs from changing state
- Supports SSTL_18 data inputs
- Checks parity on the DIMM-independent data inputs
- Partial parity output and input allows cascading of two SSTUA32866s for correct parity error processing
- Differential clock (CK and \overline{CK}) inputs
- Supports LVCMOS switching levels on the control and \overline{RESET} inputs
- Single 1.8 V supply operation (1.7 V to 2.0 V)
- Available in 96-ball, 13.5 mm × 5.5 mm, 0.8 mm ball pitch LFBGA package

3. Applications

- 400 MT/s to 667 MT/s DDR2 registered DIMMs desiring parity checking functionality

4. Ordering information

Table 1. Ordering information

$T_{amb} = 0^{\circ}C$ to $+70^{\circ}C$.

Type number	Solder process	Package		Version
		Name	Description	
SSTUA32866EC/G	Pb-free (SnAgCu solder ball compound)	LFBGA96	plastic low profile fine-pitch ball grid array package; 96 balls; body 13.5 × 5.5 × 1.05 mm	SOT536-1
SSTUA32866EC	SnPb solder ball compound	LFBGA96	plastic low profile fine-pitch ball grid array package; 96 balls; body 13.5 × 5.5 × 1.05 mm	SOT536-1

5. Functional diagram

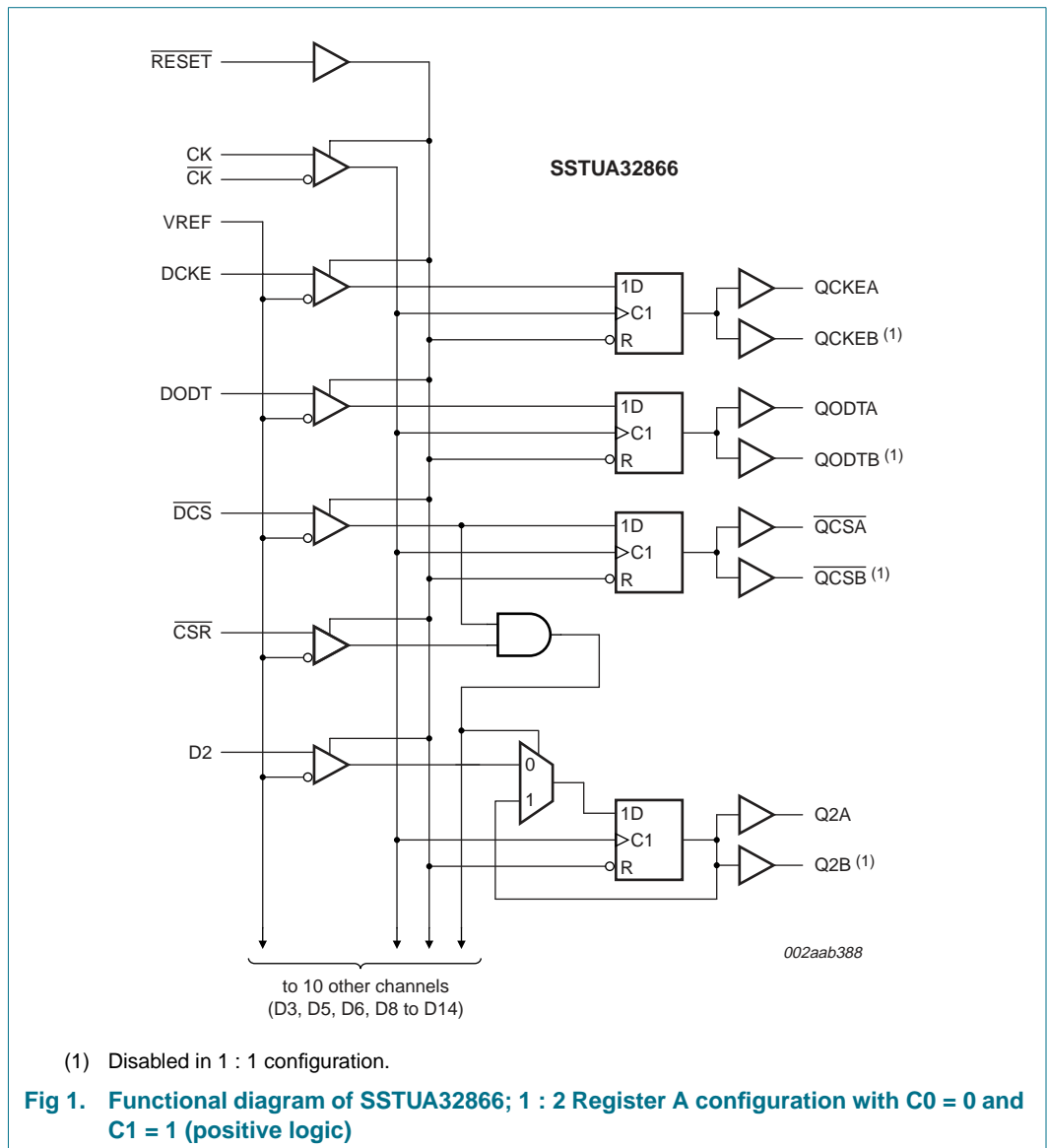

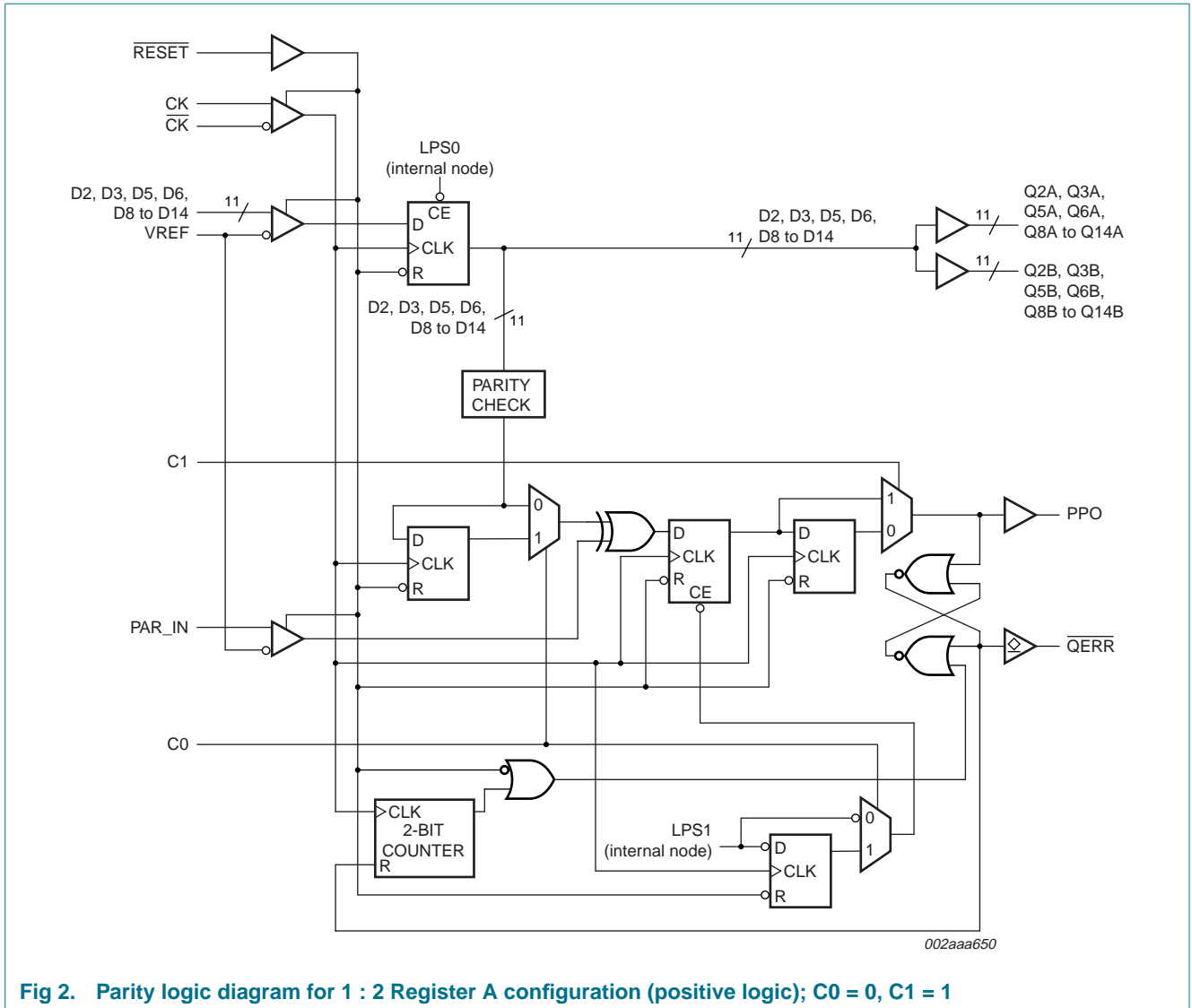
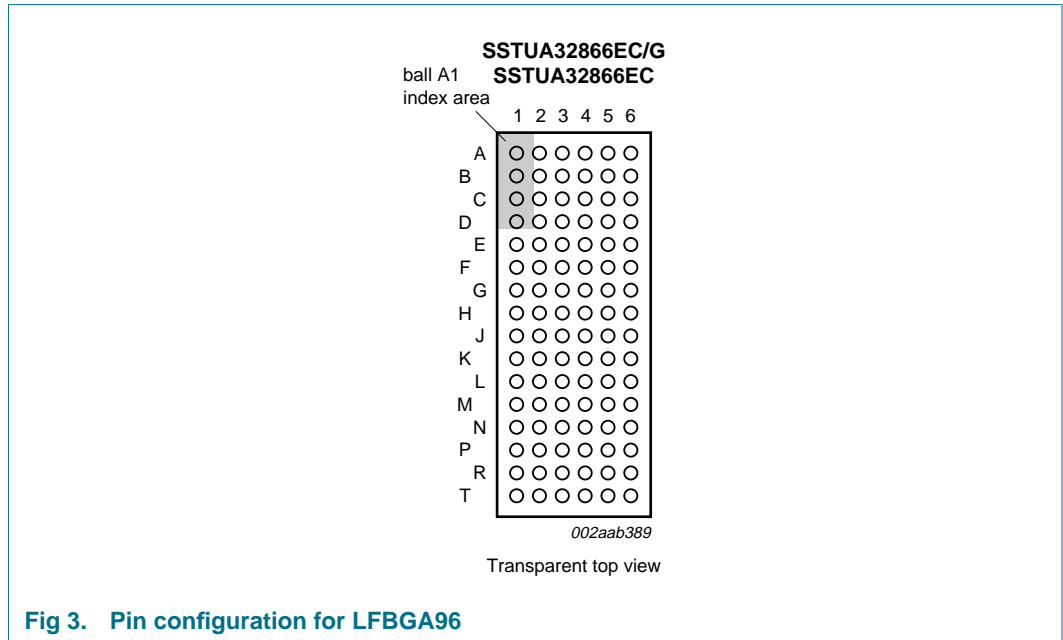

Fig 2. Parity logic diagram for 1 : 2 Register A configuration (positive logic); C0 = 0, C1 = 1

6. Pinning information

6.1 Pinning



	1	2	3	4	5	6
A	DCKE	PPO	VREF	V _{DD}	QCKE	DNU
B	D2	D15	GND	GND	Q2	Q15
C	D3	D16	V _{DD}	V _{DD}	Q3	Q16
D	DODT	\overline{QERR}	GND	GND	QODT	DNU
E	D5	D17	V _{DD}	V _{DD}	Q5	Q17
F	D6	D18	GND	GND	Q6	Q18
G	PAR_IN	\overline{RESET}	V _{DD}	V _{DD}	C1	C0
H	CK	\overline{DCS}	GND	GND	\overline{QCS}	DNU
J	\overline{CK}	\overline{CSR}	V _{DD}	V _{DD}	n.c.	n.c.
K	D8	D19	GND	GND	Q8	Q19
L	D9	D20	V _{DD}	V _{DD}	Q9	Q20
M	D10	D21	GND	GND	Q10	Q21
N	D11	D22	V _{DD}	V _{DD}	Q11	Q22
P	D12	D23	GND	GND	Q12	Q23
R	D13	D24	V _{DD}	V _{DD}	Q13	Q24
T	D14	D25	VREF	V _{DD}	Q14	Q25

002aab108

Fig 4. Ball mapping, 1 : 1 register (C0 = 0, C1 = 0)

	1	2	3	4	5	6
A	DCKE	PPO	VREF	V _{DD}	QCKEA	QCKEB
B	D2	DNU	GND	GND	Q2A	Q2B
C	D3	DNU	V _{DD}	V _{DD}	Q3A	Q3B
D	DODT	\overline{QERR}	GND	GND	QODTA	QODTB
E	D5	n.c.	V _{DD}	V _{DD}	Q5A	Q5B
F	D6	n.c.	GND	GND	Q6A	Q6B
G	PAR_IN	\overline{RESET}	V _{DD}	V _{DD}	C1	C0
H	CK	\overline{DCS}	GND	GND	\overline{QCSA}	\overline{QCSB}
J	\overline{CK}	\overline{CSR}	V _{DD}	V _{DD}	n.c.	n.c.
K	D8	DNU	GND	GND	Q8A	Q8B
L	D9	DNU	V _{DD}	V _{DD}	Q9A	Q9B
M	D10	DNU	GND	GND	Q10A	Q10B
N	D11	DNU	V _{DD}	V _{DD}	Q11A	Q11B
P	D12	DNU	GND	GND	Q12A	Q12B
R	D13	DNU	V _{DD}	V _{DD}	Q13A	Q13B
T	D14	DNU	VREF	V _{DD}	Q14A	Q14B

002aab109

Fig 5. Ball mapping, 1 : 2 Register A (C0 = 0, C1 = 1)

	1	2	3	4	5	6
A	D1	PPO	VREF	V _{DD}	Q1A	Q1B
B	D2	DNU	GND	GND	Q2A	Q2B
C	D3	DNU	V _{DD}	V _{DD}	Q3A	Q3B
D	D4	\overline{QERR}	GND	GND	Q4A	Q4B
E	D5	DNU	V _{DD}	V _{DD}	Q5A	Q5B
F	D6	DNU	GND	GND	Q6A	Q6B
G	PAR_IN	\overline{RESET}	V _{DD}	V _{DD}	C1	C0
H	CK	\overline{DCS}	GND	GND	\overline{QCSA}	\overline{QCSB}
J	\overline{CK}	\overline{CSR}	V _{DD}	V _{DD}	n.c.	n.c.
K	D8	DNU	GND	GND	Q8A	Q8B
L	D9	DNU	V _{DD}	V _{DD}	Q9A	Q9B
M	D10	DNU	GND	GND	Q10A	Q10B
N	DODT	DNU	V _{DD}	V _{DD}	QODTA	QODTB
P	D12	DNU	GND	GND	Q12A	Q12B
R	D13	DNU	V _{DD}	V _{DD}	Q13A	Q13B
T	DCKE	DNU	VREF	V _{DD}	QCKEA	QCKEB

002aab110

Fig 6. Ball mapping, 1 : 2 Register B (C0 = 1, C1 = 1)

6.2 Pin description

Table 2. Pin description

Symbol	Pin	Type	Description
GND	B3, B4, D3, D4, F3, F4, H3, H4, K3, K4, M3, M4, P3, P4	ground input	ground
V _{DD}	A4, C3, C4, E3, E4, G3, G4, J3, J4, L3, L4, N3, N4, R3, R4, T4	1.8 V nominal	power supply voltage
VREF	A3, T3	0.9 V nominal	input reference voltage
CK	H1	Differential input	positive master clock input
\overline{CK}	J1	Differential input	negative master clock input
C0	G6	LVC MOS inputs	Configuration control inputs; Register A or Register B and 1 : 1 mode or 1 : 2 mode select.
C1	G5		
\overline{RESET}	G2	LVC MOS input	Asynchronous reset input (active LOW). Resets registers and disables VREF data and clock.
\overline{CSR}	J2	SSTL ₁₈ input	Chip select inputs (active LOW). Disables D1 to D25 ^[2] outputs switching when both inputs are HIGH.
\overline{DCS}	H2		
D1 to D25	^[1]	SSTL ₁₈ input	Data input. Clocked in on the crossing of the rising edge of CK and the falling edge of CK.
DODT	^[1]	SSTL ₁₈ input	The outputs of this register bit will not be suspended by the \overline{DCS} and \overline{CSR} control.
DCKE	^[1]	SSTL ₁₈ input	The outputs of this register bit will not be suspended by the \overline{DCS} and \overline{CSR} control.
PAR_IN	G1	SSTL ₁₈ input	Parity input. Arrives one clock cycle after the corresponding data input.
Q1 to Q25, Q2A to Q14A, Q1B to Q14B	^[1]	1.8 V CMOS outputs	Data outputs that are suspended by the \overline{DCS} and \overline{CSR} control ^[3] .
PPO	A2	1.8 V CMOS output	Partial parity out. Indicates odd parity of inputs D1 to D25 ^[2] .
\overline{QCS} , \overline{QCSA} , \overline{QCSB}	^[1]	1.8 V CMOS output	Data output that will not be suspended by the \overline{DCS} and \overline{CSR} control.
QODT, QODTA, QODTB	^[1]	1.8 V CMOS output	Data output that will not be suspended by the \overline{DCS} and \overline{CSR} control.
QCKE, QCKEA, QCKEB	^[1]	1.8 V CMOS output	Data output that will not be suspended by the \overline{DCS} and \overline{CSR} control.

Table 2. Pin description ...continued

Symbol	Pin	Type	Description
\overline{QERR}	D2	open-drain output	Output error bit (active LOW). Generated one clock cycle after the corresponding data output
n.c.	[1]	-	Not connected. Ball present but no internal connection to the die.
DNU	[1]	-	Do not use. Inputs are in standby-equivalent mode and outputs are driven LOW.

[1] Depends on configuration. See [Figure 4](#), [Figure 5](#), and [Figure 6](#) for ball number.

[2] Data inputs = D2, D3, D5, D6, D8 to D25 when C0 = 0 and C1 = 0.
 Data inputs = D2, D3, D5, D6, D8 to D14 when C0 = 0 and C1 = 1.
 Data inputs = D1 to D6, D8 to D10, D12, D13 when C0 = 1 and C1 = 1.

[3] Data outputs = Q2, Q3, Q5, Q6, Q8 to Q25 when C0 = 0 and C1 = 0.
 Data outputs = Q2, Q3, Q5, Q6, Q8 to Q14 when C0 = 0 and C1 = 1.
 Data outputs = Q1 to Q6, Q8 to Q10, Q12, Q13 when C0 = 1 and C1 = 1.

7. Functional description

The SSTUA32866 is a 25-bit 1 : 1 or 14-bit 1 : 2 configurable registered buffer with parity, designed for 1.7 V to 2.0 V V_{DD} operation.

All clock and data inputs are compatible with the JEDEC standard for SSTL_18. The control and reset (\overline{RESET}) inputs are LVCMOS. All data outputs are 1.8 V CMOS drivers that have been optimized to drive the DDR2 DIMM load, and meet SSTL_18 specifications. The error (\overline{QERR}) output is 1.8 V open-drain driver.

The SSTUA32866 operates from a differential clock (CK and \overline{CK}). Data are registered at the crossing of CK going HIGH, and \overline{CK} going LOW.

The C0 input controls the pinout configuration for the 1 : 2 pinout from A configuration (when LOW) to B configuration (when HIGH). The C1 input controls the pinout configuration from 25-bit 1 : 1 (when LOW) to 14-bit 1 : 2 (when HIGH).

The SSTUA32866 accepts a parity bit from the memory controller on its parity bit (PAR_IN) input, compares it with the data received on the DIMM-independent D-inputs and indicates whether a parity error has occurred on its open-drain \overline{QERR} pin (active LOW). The convention is even parity, that is, valid parity is defined as an even number of ones across the DIMM-independent data inputs combined with the parity input bit.

When used as a single device, the C0 and C1 inputs are tied LOW. In this configuration, parity is checked on the PAR_IN input which arrives one cycle after the input data to which it applies. The Partial-Parity-Out (PPO) and \overline{QERR} signals are produced three cycles after the corresponding data inputs.

When used in pairs, the C0 input of the first register is tied LOW and the C0 input of the second register is tied HIGH. The C1 input of both registers are tied HIGH. Parity, which arrives one cycle after the data input to which it applies, is checked on the PAR_IN input of the first device. The PPO and \overline{QERR} signals are produced on the second device three clock cycles after the corresponding data inputs. The PPO output of the first register is

cascaded to the PAR_IN of the second register. The \overline{QERR} output of the first register is left floating and the valid error information is latched on the \overline{QERR} output of the second register.

If an error occurs and the \overline{QERR} output is driven LOW, it stays latched LOW for two clock cycles or until \overline{RESET} is driven LOW. The DIMM-dependent signals (DCKE, \overline{DCS} , DODT, and \overline{CSR}) are not included in the parity check computation.

The device supports low-power standby operation. When \overline{RESET} is LOW, the differential input receivers are disabled, and undriven (floating) data, clock and reference voltage (VREF) inputs are allowed. In addition, when \overline{RESET} is LOW all registers are reset, and all outputs are forced LOW. The LVC MOS \overline{RESET} input must always be held at a valid logic HIGH or LOW level.

The device also supports low-power active operation by monitoring both system chip select (\overline{DCS} and \overline{CSR}) inputs and will gate the Qn and PPO outputs from changing states when both \overline{DCS} and \overline{CSR} inputs are HIGH. If either \overline{DCS} or \overline{CSR} input is LOW, the Qn and PPO outputs will function normally. The \overline{RESET} input has priority over the \overline{DCS} and \overline{CSR} control and when driven LOW will force the Qn and PPO outputs LOW, and the \overline{QERR} output HIGH. If the \overline{DCS} control functionality is not desired, then the \overline{CSR} input can be hard-wired to ground, in which case, the setup time requirement for \overline{DCS} would be the same as for the other Dn data inputs. To control the low-power mode with \overline{DCS} only, then the \overline{CSR} input should be pulled up to V_{DD} through a pull-up resistor.

To ensure defined outputs from the register before a stable clock has been supplied, \overline{RESET} must be held in the LOW state during power-up.

In the DDR2 RDIMM application, \overline{RESET} is specified to be completely asynchronous with respect to CK and \overline{CK} . Therefore, no timing relationship can be guaranteed between the two. When entering reset, the register will be cleared and the Qn outputs will be driven LOW quickly, relative to the time to disable the differential input receivers. However, when coming out of reset, the register will become active quickly, relative to the time to enable the differential input receivers. As long as the data inputs are LOW, and the clock is stable during the time from the LOW-to-HIGH transition of \overline{RESET} until the input receivers are fully enabled, the design of the SSTUA32866 must ensure that the outputs will remain LOW, thus ensuring no glitches on the output.

7.1 Function table

Table 3. Function table (each flip-flop)

L = LOW voltage level; H = HIGH voltage level; X = don't care; ↑ = LOW-to-HIGH transition; ↓ = HIGH-to-LOW transition

Inputs						Outputs ^[1]		
RESET	DCS	CSR	CK	CK̄	Dn, DODTn, DCKEn	Qn	QCS	QODT, QCKE
H	L	L	↑	↓	L	L	L	L
H	L	L	↑	↓	H	H	L	H
H	L	L	L or H	L or H	X	Q ₀	Q ₀	Q ₀
H	L	H	↑	↓	L	L	L	L
H	L	H	↑	↓	H	H	L	H
H	L	H	L or H	L or H	X	Q ₀	Q ₀	Q ₀
H	H	L	↑	↓	L	L	H	L
H	H	L	↑	↓	H	H	H	H
H	H	L	L or H	L or H	X	Q ₀	Q ₀	Q ₀
H	H	H	↑	↓	L	Q ₀	H	L
H	H	H	↑	↓	H	Q ₀	H	H
H	H	H	L or H	L or H	X	Q ₀	Q ₀	Q ₀
L	X or floating	X or floating	X or floating	X or floating	X or floating	L	L	L

[1] Q₀ is the previous state of the associated output.

Table 4. Parity and standby function table

L = LOW voltage level; H = HIGH voltage level; X = don't care; ↑ = LOW-to-HIGH transition; ↓ = HIGH-to-LOW transition

Inputs						Outputs ^[1]		
RESET	DCS	CSR	CK	CK̄	Σ of inputs = H (D1 to D25)	PAR_IN ^[2]	PPO ^[3]	QERR ^[4]
H	L	X	↑	↓	even	L	L	H
H	L	X	↑	↓	odd	L	H	L
H	L	X	↑	↓	even	H	H	L
H	L	X	↑	↓	odd	H	L	H
H	H	L	↑	↓	even	L	L	H
H	H	L	↑	↓	odd	L	H	L
H	H	L	↑	↓	even	H	H	L
H	H	L	↑	↓	odd	H	L	H
H	H	H	↑	↓	X	X	PPO ₀	QERR ₀
H	X	X	L or H	L or H	X	X	PPO ₀	QERR ₀
L	X or floating	X or floating	X or floating	X or floating	X or floating	X or floating	L	H

[1] PPO₀ is the previous state of output PPO; QERR₀ is the previous state of output QERR.

[2] Data inputs = D2, D3, D5, D6, D8 to D25 when C0 = 0 and C1 = 0.
 Data inputs = D2, D3, D5, D6, D8 to D14 when C0 = 0 and C1 = 1.
 Data inputs = D1 to D6, D8 to D10, D12, D13 when C0 = 1 and C1 = 1.

[3] PAR_IN arrives one clock cycle (C0 = 0), or two clock cycles (C0 = 1), after the data to which it applies.

[4] This condition assumes QERR is HIGH at the crossing of CK going HIGH and CK̄ going LOW. If QERR is LOW, it stays latched LOW for two clock cycles or until RESET is driven LOW.

8. Limiting values

Table 5. Limiting values

In accordance with the Absolute Maximum Rating System (IEC 60134).

Symbol	Parameter	Conditions	Min	Max	Unit
V _{DD}	supply voltage		-0.5	+2.5	V
V _I	input voltage	receiver	-0.5 ^[1]	+2.5 ^[2]	V
V _O	output voltage	driver	-0.5 ^[1]	V _{DD} + 0.5 ^[2]	V
I _{IK}	input clamping current	V _I < 0 V or V _I > V _{DD}	-	-50	mA
I _{OK}	output clamping current	V _O < 0 V or V _O > V _{DD}	-	±50	mA
I _O	output current	continuous; 0 V < V _O < V _{DD}	-	±50	mA
I _{CCC}	continuous current through each V _{DD} or GND pin		-	±100	mA
T _{stg}	storage temperature		-65	+150	°C
V _{esd}	electrostatic discharge voltage	Human Body Model (HBM); 1.5 kΩ; 100 pF	2	-	kV
		Machine Model (MM); 0 Ω; 200 pF	200	-	V

[1] The input and output negative-voltage ratings may be exceeded if the input and output clamp-current ratings are observed.

[2] This value is limited to 2.5 V maximum.

9. Recommended operating conditions

Table 6. Recommended operating conditions

Symbol	Parameter	Conditions	Min	Typ	Max	Unit
V _{DD}	supply voltage		1.7	-	2.0	V
V _{ref}	reference voltage		0.49 × V _{DD}	0.50 × V _{DD}	0.51 × V _{DD}	V
V _T	termination voltage		V _{ref} - 0.040	V _{ref}	V _{ref} + 0.040	V
V _I	input voltage		0	-	V _{DD}	V
V _{IH(AC)}	AC HIGH-level input voltage	data (Dn), $\overline{\text{CSR}}$, and PAR_IN inputs	V _{ref} + 0.250	-	-	V
V _{IL(AC)}	AC LOW-level input voltage	data (Dn), $\overline{\text{CSR}}$, and PAR_IN inputs	-	-	V _{ref} - 0.250	V
V _{IH(DC)}	DC HIGH-level input voltage	data (Dn), $\overline{\text{CSR}}$, and PAR_IN inputs	V _{ref} + 0.125	-	-	V
V _{IL(DC)}	DC LOW-level input voltage	data (Dn), $\overline{\text{CSR}}$, and PAR_IN inputs	-	-	V _{ref} - 0.125	V
V _{IH}	HIGH-level input voltage	$\overline{\text{RESET}}$, Cn	^[1] 0.65 × V _{DD}	-	-	V
V _{IL}	LOW-level input voltage	$\overline{\text{RESET}}$, Cn	^[1] -	-	0.35 × V _{DD}	V
V _{ICR}	common mode input voltage range	CK, $\overline{\text{CK}}$	^[2] 0.675	-	1.125	V
V _{ID}	differential input voltage	CK, $\overline{\text{CK}}$	^[2] 600	-	-	mV
I _{OH}	HIGH-level output current		-	-	-8	mA
I _{OL}	LOW-level output current		-	-	8	mA
T _{amb}	ambient temperature	operating in free air	0	-	+70	°C

[1] The $\overline{\text{RESET}}$ and Cn inputs of the device must be held at valid levels (not floating) to ensure proper device operation.

[2] The differential inputs must not be floating, unless $\overline{\text{RESET}}$ is LOW.

10. Characteristics

Table 7. Characteristics

At recommended operating conditions (see [Table 6](#)); unless otherwise specified.

Symbol	Parameter	Conditions	Min	Typ	Max	Unit
V_{OH}	HIGH-level output voltage	$I_{OH} = -6 \text{ mA}$; $V_{DD} = 1.7 \text{ V}$	1.2	-	-	V
V_{OL}	LOW-level output voltage	$I_{OL} = 6 \text{ mA}$; $V_{DD} = 1.7 \text{ V}$	-	-	0.5	V
I_I	input current	all inputs; $V_I = V_{DD}$ or GND; $V_{DD} = 2.0 \text{ V}$	-	-	± 5	μA
I_{DD}	supply current	static standby; $\overline{\text{RESET}} = \text{GND}$; $I_O = 0 \text{ mA}$; $V_{DD} = 2.0 \text{ V}$	-	-	2	mA
		static operating; $\overline{\text{RESET}} = V_{DD}$; $I_O = 0 \text{ mA}$; $V_{DD} = 2.0 \text{ V}$; $V_I = V_{IH(AC)}$ or $V_{IL(AC)}$	-	-	40	mA
I_{DD}	dynamic operating current per MHz	clock only; $\overline{\text{RESET}} = V_{DD}$; $V_I = V_{IH(AC)}$ or $V_{IL(AC)}$; CK and $\overline{\text{CK}}$ switching at 50 % duty cycle. $I_O = 0 \text{ mA}$; $V_{DD} = 1.8 \text{ V}$	-	16	-	μA
		per each data input, 1 : 1 mode; $\overline{\text{RESET}} = V_{DD}$; $V_I = V_{IH(AC)}$ or $V_{IL(AC)}$; CK and $\overline{\text{CK}}$ switching at 50 % duty cycle. One data input switching at half clock frequency, 50 % duty cycle. $I_O = 0 \text{ mA}$; $V_{DD} = 1.8 \text{ V}$	-	11	-	μA
		per each data input, 1 : 2 mode; $\overline{\text{RESET}} = V_{DD}$; $V_I = V_{IH(AC)}$ or $V_{IL(AC)}$; CK and $\overline{\text{CK}}$ switching at 50 % duty cycle. One data input switching at half clock frequency, 50 % duty cycle. $I_O = 0 \text{ mA}$; $V_{DD} = 1.8 \text{ V}$	-	19	-	μA
C_i	input capacitance	data and $\overline{\text{CSR}}$ inputs; $V_I = V_{ref} \pm 250 \text{ mV}$; $V_{DD} = 1.8 \text{ V}$	2.5	-	3.5	pF
		CK and $\overline{\text{CK}}$ inputs; $V_{ICR} = 0.9 \text{ V}$; $V_{i(p-p)} = 600 \text{ mV}$; $V_{DD} = 1.8 \text{ V}$	2	-	3	pF
		$\overline{\text{RESET}}$ input; $V_I = V_{DD}$ or GND; $V_{DD} = 1.8 \text{ V}$	3	-	4	pF

Table 8. Timing requirements

At recommended operating conditions (see [Table 6](#)), unless otherwise specified. See [Figure 2](#).

Symbol	Parameter	Conditions	Min	Typ	Max	Unit
f_{clock}	clock frequency		-	-	450	MHz
t_{W}	pulse width	CK, $\overline{\text{CK}}$ HIGH or LOW	1	-	-	ns
t_{ACT}	differential inputs active time		[1][2]	-	10	ns
t_{INACT}	differential inputs inactive time		[1][3]	-	15	ns
t_{su}	set-up time	$\overline{\text{DCS}}$ before CK \uparrow , $\overline{\text{CK}}\downarrow$, $\overline{\text{CSR}}$ HIGH; $\overline{\text{CSR}}$ before CK \uparrow , $\overline{\text{CK}}\downarrow$, $\overline{\text{DCS}}$ HIGH	0.7	-	-	ns
		$\overline{\text{DCS}}$ before CK \uparrow , $\overline{\text{CK}}\downarrow$, $\overline{\text{CSR}}$ LOW	0.5	-	-	ns
		DODT, DCKE and data (Dn) before CK \uparrow , CK \downarrow	0.5	-	-	ns
		PAR_IN before CK \uparrow , $\overline{\text{CK}}\downarrow$	0.5	-	-	ns
t_{h}	hold time	DCS, DODT, DCKE and data (Dn) after CK \uparrow , $\overline{\text{CK}}\downarrow$	0.5	-	-	ns
		PAR_IN after CK \uparrow , $\overline{\text{CK}}\downarrow$	0.5	-	-	ns

[1] This parameter is not necessarily production tested.

[2] VREF must be held at a valid input voltage level and data inputs must be held LOW for a minimum time of $t_{\text{ACT(max)}}$ after $\overline{\text{RESET}}$ is taken HIGH.

[3] VREF, data and clock inputs must be held at valid levels (not floating) a minimum time of $t_{\text{INACT(max)}}$ after $\overline{\text{RESET}}$ is taken LOW.

Table 9. Switching characteristics

At recommended operating conditions (see [Table 6](#)), unless otherwise specified. See [Section 11.1](#).

Symbol	Parameter	Conditions	Min	Typ	Max	Unit
f_{max}	maximum input clock frequency		450	-	-	MHz
t_{PDM}	peak propagation delay	single bit switching; from CK \uparrow and $\overline{\text{CK}}\downarrow$ to Qn	[1]	1.2	-	1.8 ns
t_{PD}	propagation delay	from CK \uparrow and $\overline{\text{CK}}\downarrow$ to PPO	0.5	-	1.8	ns
t_{LH}	LOW-to-HIGH delay	from CK \uparrow and $\overline{\text{CK}}\downarrow$ to $\overline{\text{QERR}}$	1.2	-	3	ns
t_{HL}	HIGH-to-LOW delay	from CK \uparrow and $\overline{\text{CK}}\downarrow$ to $\overline{\text{QERR}}$	1	-	2.4	ns
t_{PDMSS}	simultaneous switching peak propagation delay	from CK \uparrow and $\overline{\text{CK}}\downarrow$ to Qn	[1][2]	-	-	2.0 ns
t_{PHL}	HIGH-to-LOW propagation delay	from $\overline{\text{RESET}}\downarrow$ to Qn \downarrow	-	-	3	ns
		from $\overline{\text{RESET}}\downarrow$ to PPO \downarrow	-	-	3	ns
t_{PLH}	LOW-to-HIGH propagation delay	from $\overline{\text{RESET}}\downarrow$ to $\overline{\text{QERR}}\uparrow$	-	-	3	ns

[1] Includes 350 ps of test-load transmission line delay.

[2] This parameter is not necessarily production tested.

Table 10. Data output edge rates

At recommended operating conditions (see [Table 6](#)), unless otherwise specified. See [Section 11.2](#).

Symbol	Parameter	Conditions	Min	Typ	Max	Unit
dV/dt_{r}	rising edge slew rate	from 20 % to 80 %	1	-	4	V/ns
dV/dt_{f}	falling edge slew rate	from 80 % to 20 %	1	-	4	V/ns
dV/dt_{Δ}	absolute difference between dV/dt_{r} and dV/dt_{f}	from 20 % or 80 % to 80 % or 20 %	-	-	1	V/ns

10.1 Timing diagrams

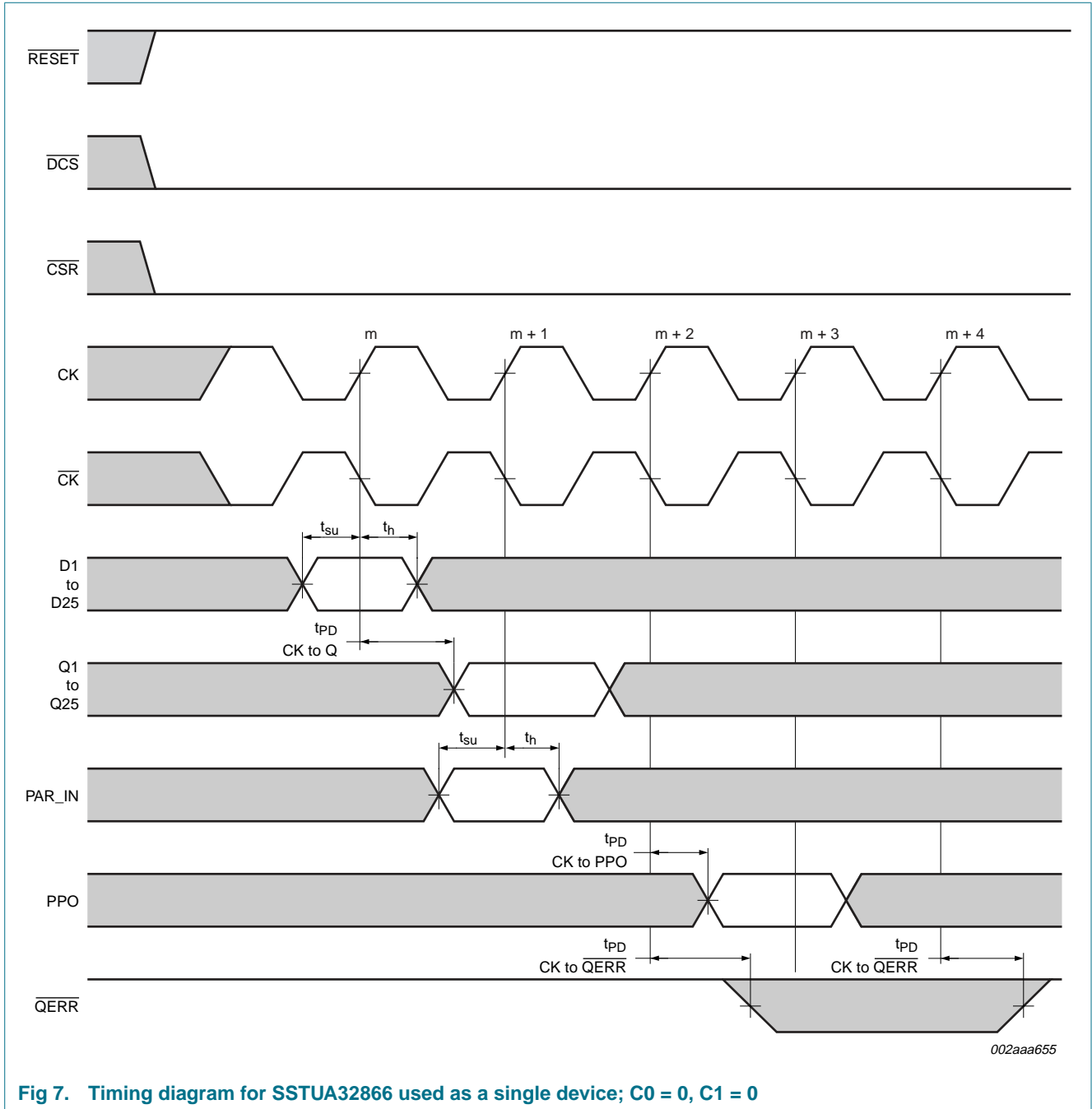
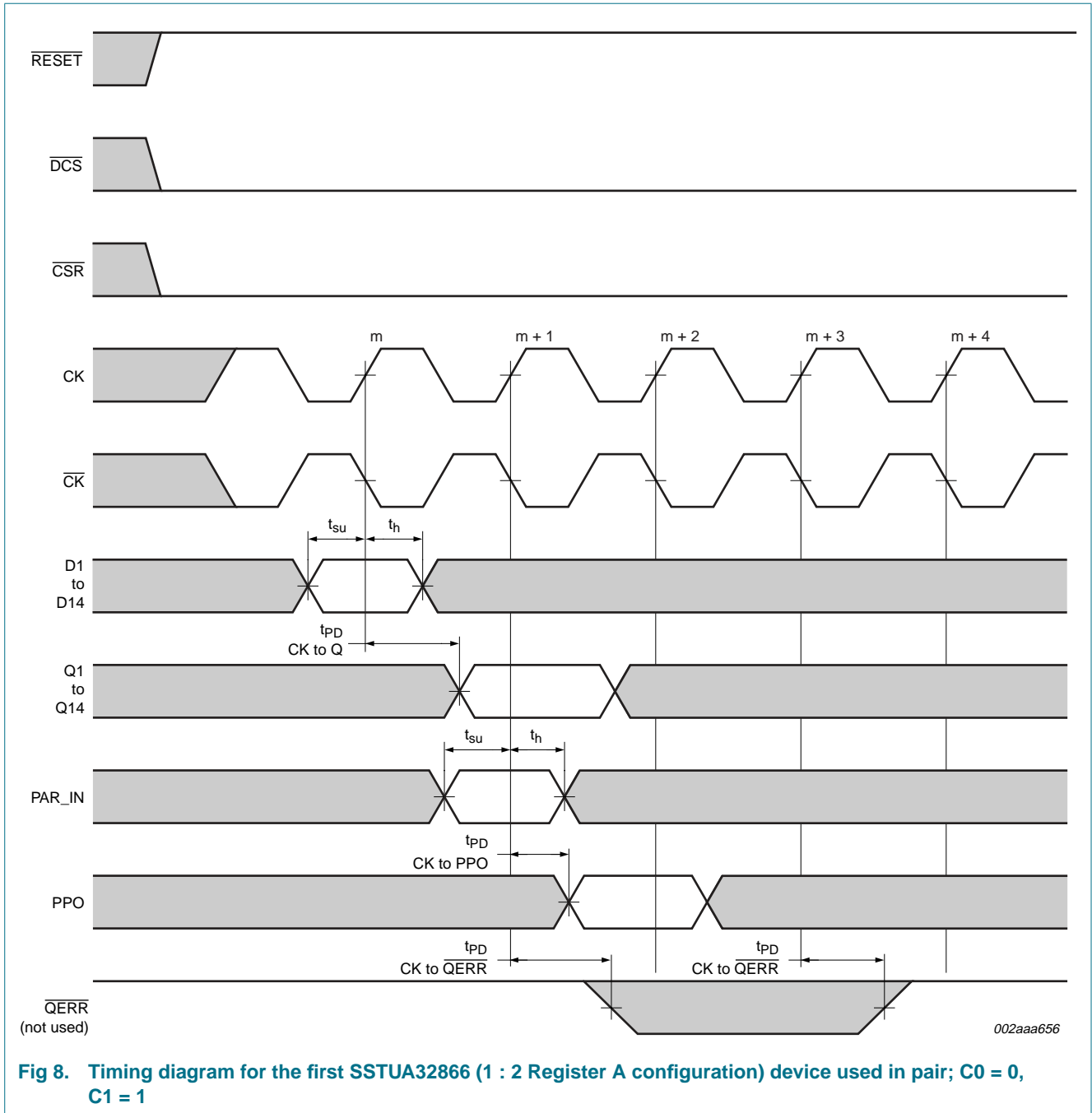
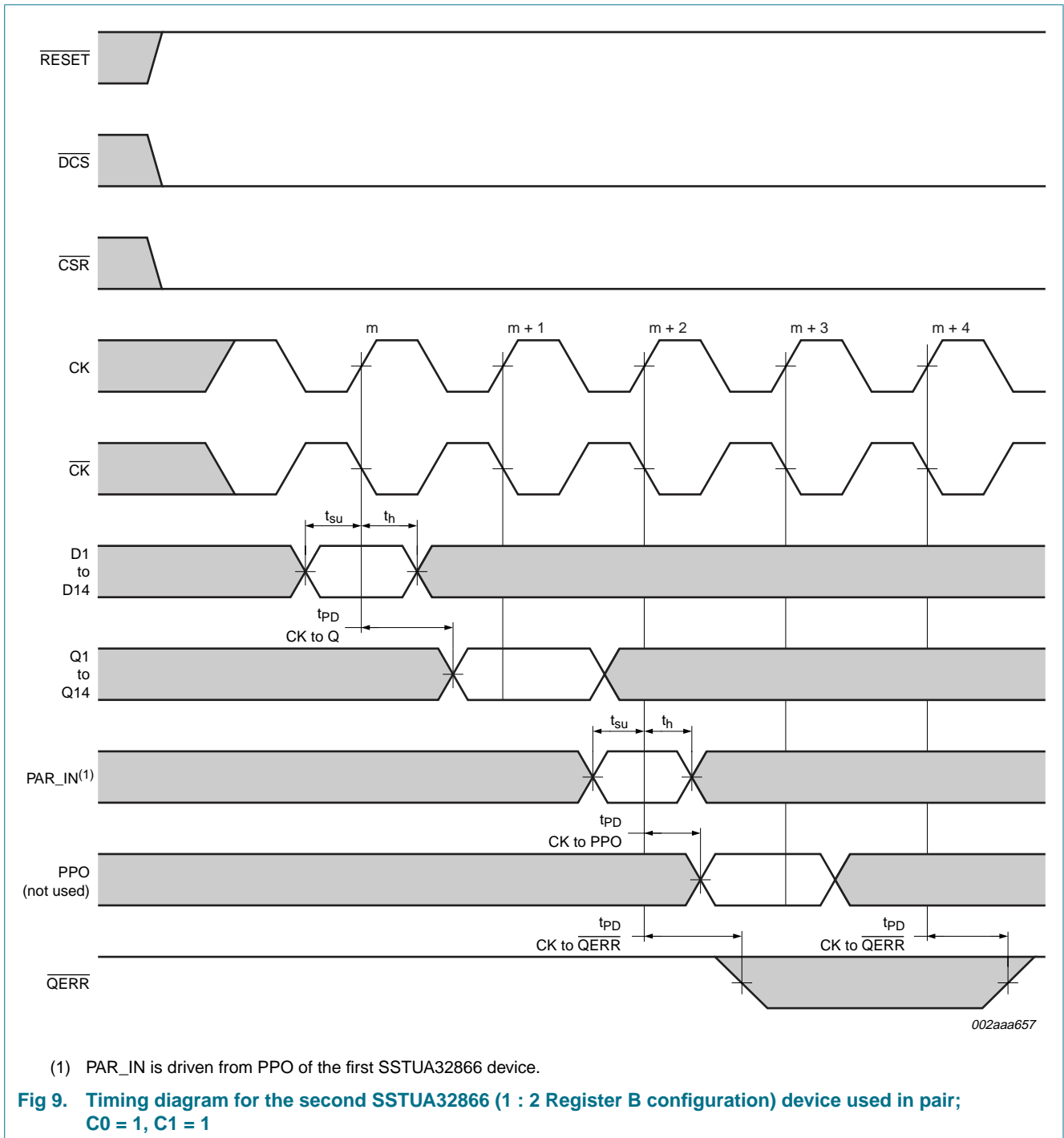

Fig 7. Timing diagram for SSTUA32866 used as a single device; C0 = 0, C1 = 0





11. Test information

11.1 Parameter measurement information for data output load circuit

$V_{DD} = 1.8 \text{ V} \pm 0.1 \text{ V}$.

All input pulses are supplied by generators having the following characteristics: PRR $\leq 10 \text{ MHz}$; $Z_0 = 50 \Omega$; input slew rate = $1 \text{ V/ns} \pm 20 \%$, unless otherwise specified.

The outputs are measured one at a time with one transition per measurement.

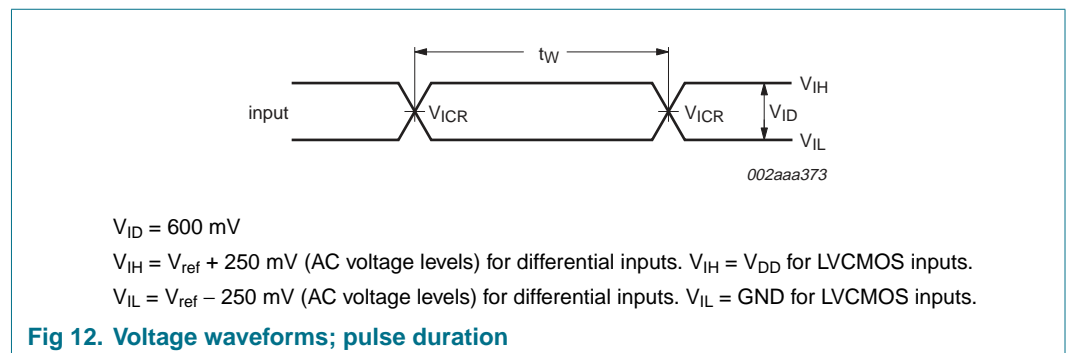
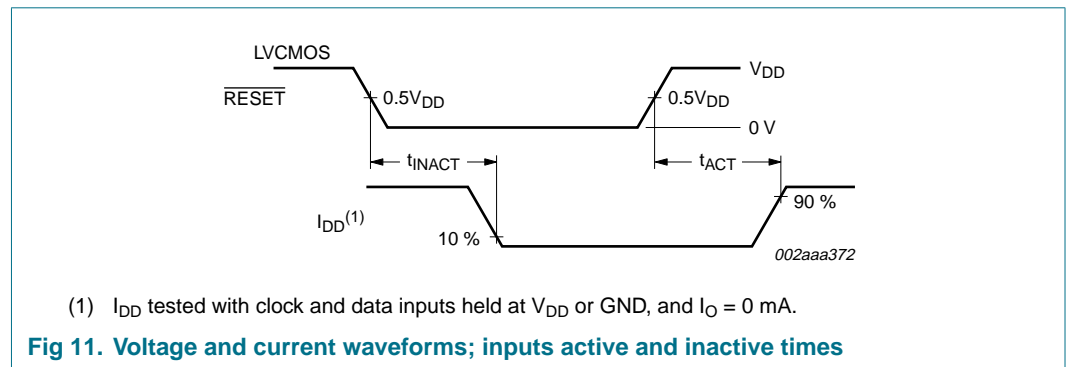
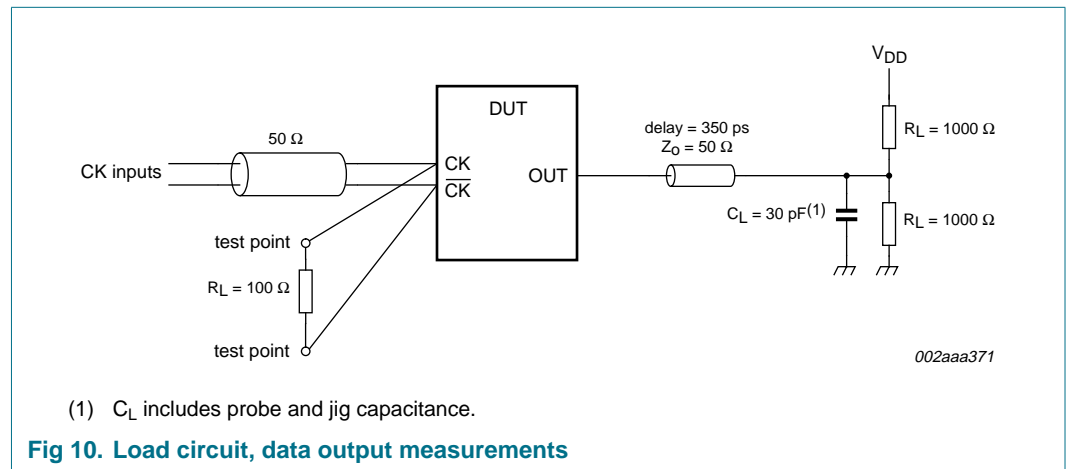

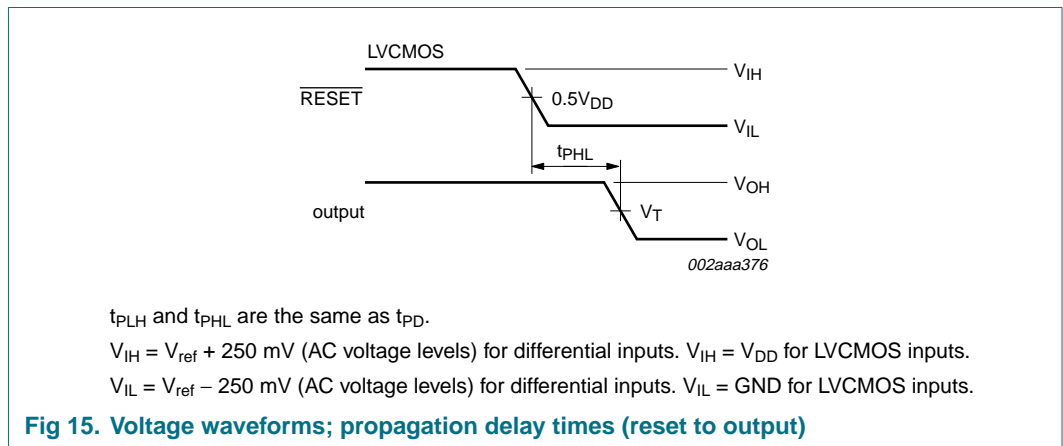
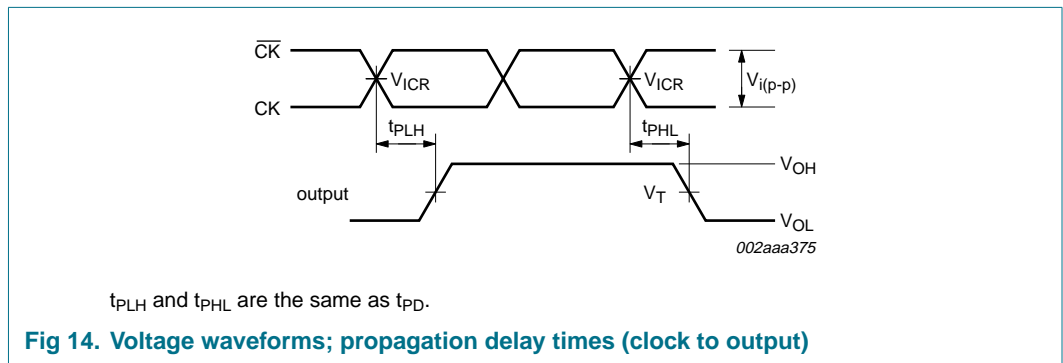
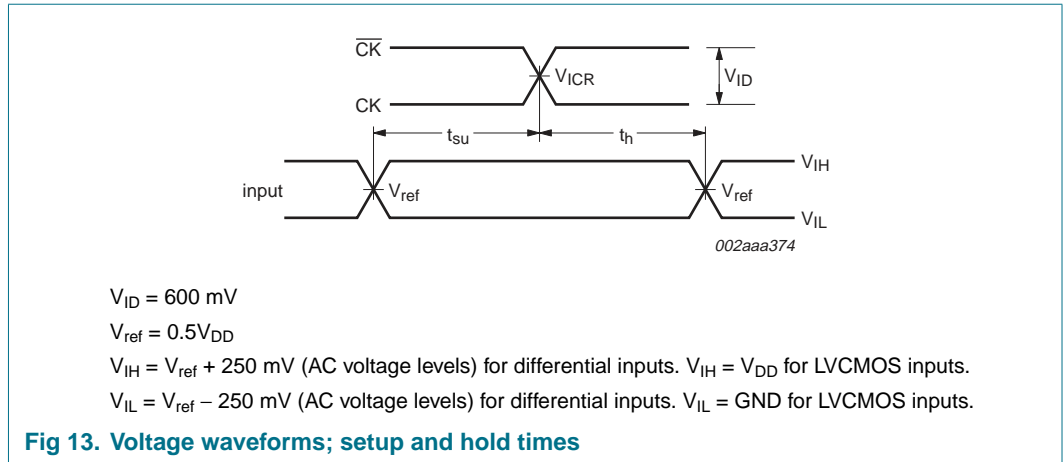

11.2 Data output slew rate measurement information

$V_{DD} = 1.8\text{ V} \pm 0.1\text{ V}$.

All input pulses are supplied by generators having the following characteristics:
 $PRR \leq 10\text{ MHz}$; $Z_0 = 50\ \Omega$; input slew rate = $1\text{ V/ns} \pm 20\%$, unless otherwise specified.

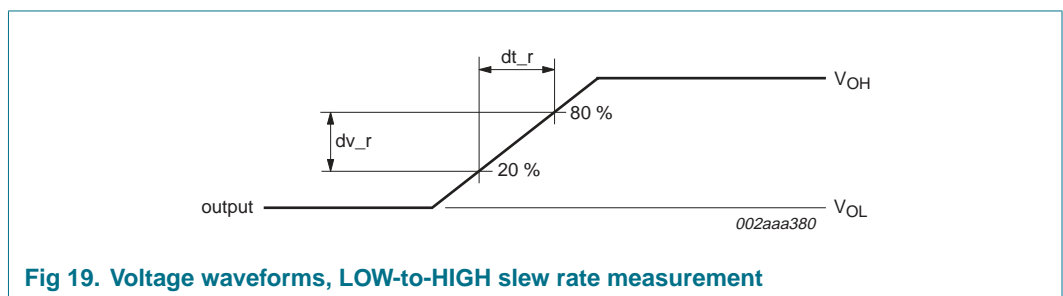
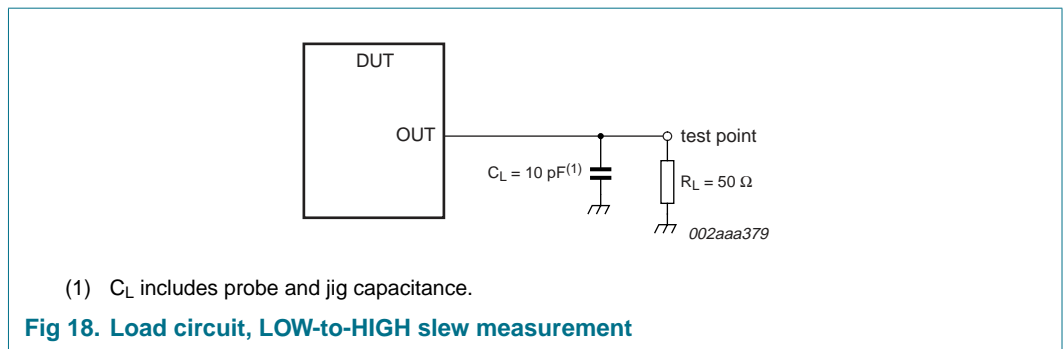
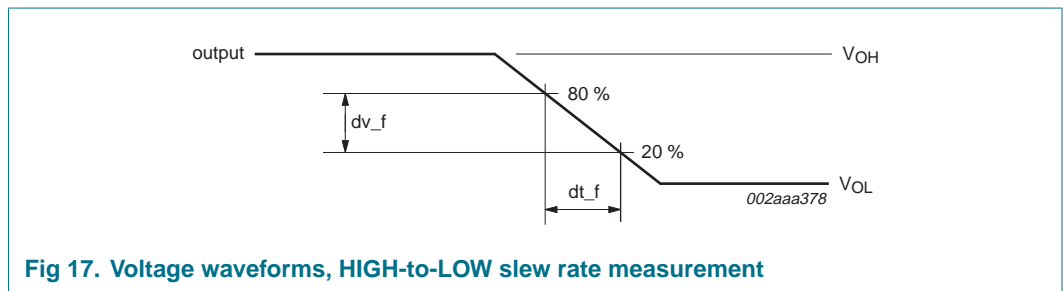
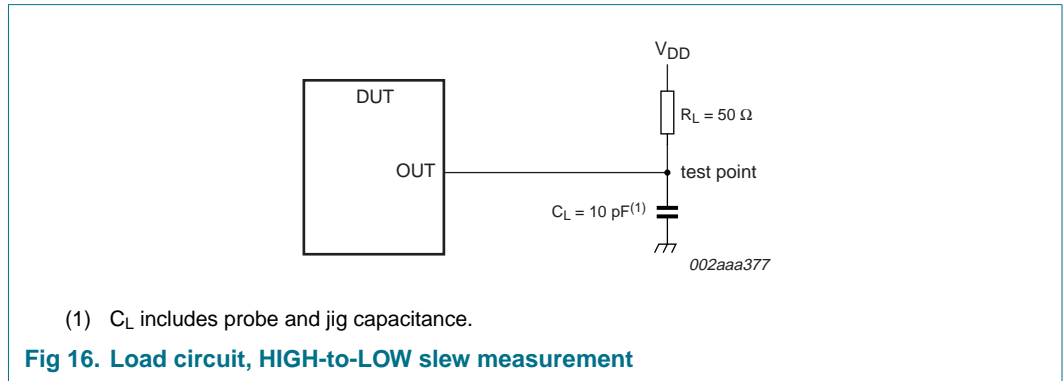

11.3 Error output load circuit and voltage measurement information

$V_{DD} = 1.8 \text{ V} \pm 0.1 \text{ V}$.

All input pulses are supplied by generators having the following characteristics:
 PRR $\leq 10 \text{ MHz}$; $Z_0 = 50 \Omega$; input slew rate = $1 \text{ V/ns} \pm 20 \%$, unless otherwise specified.

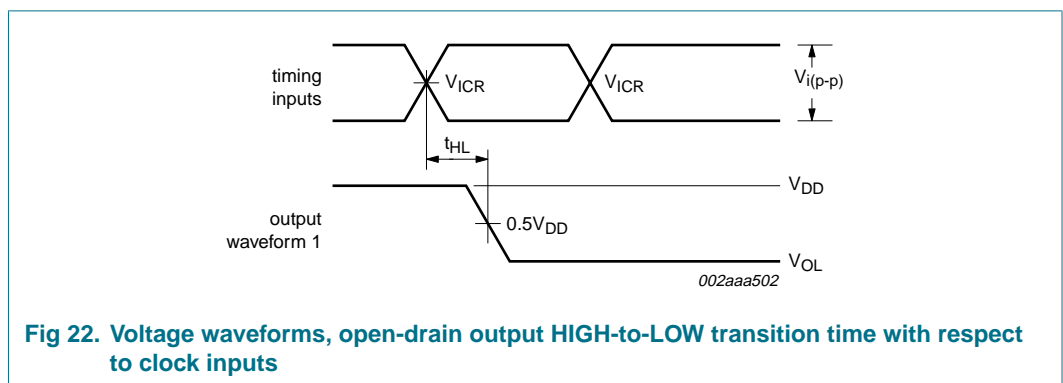
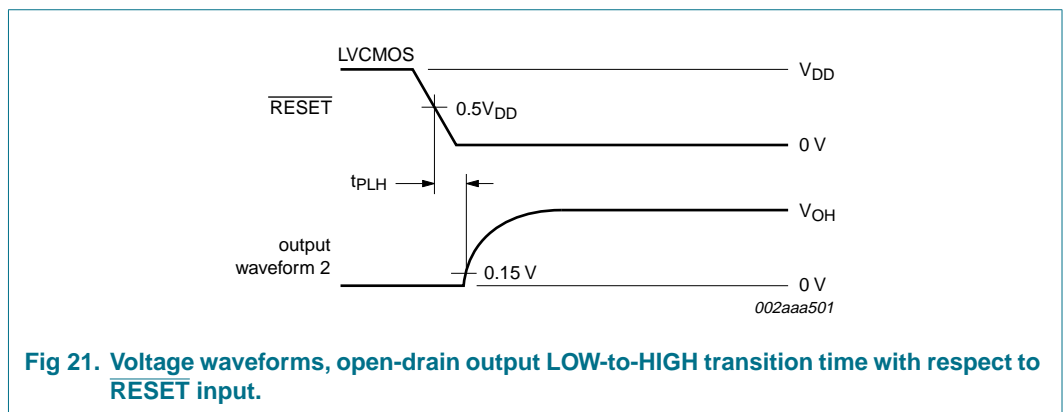
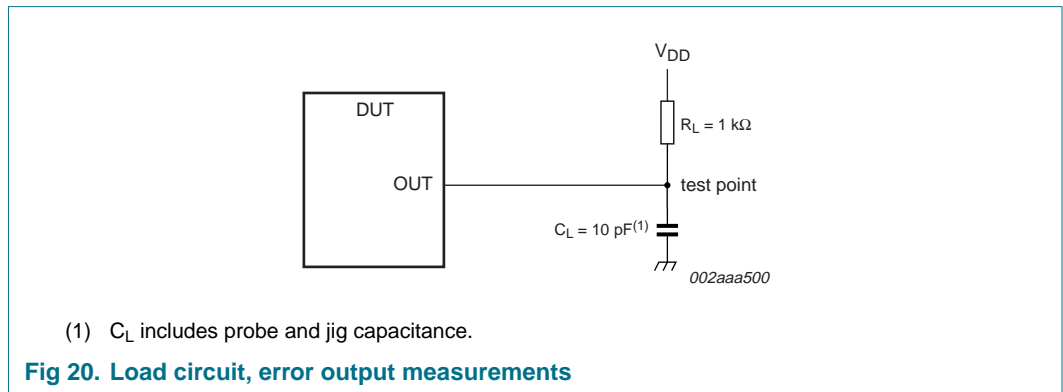

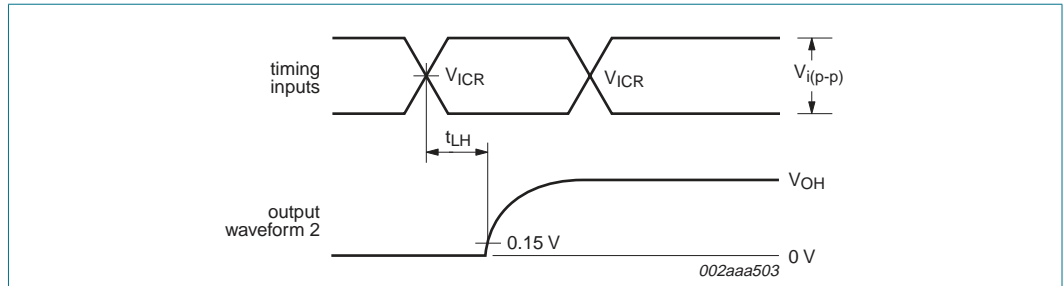

Fig 23. Voltage waveforms, open-drain output LOW-to-HIGH transition time with respect to clock inputs

11.4 Partial parity out load circuit and voltage measurement information

$V_{DD} = 1.8 V \pm 0.1 V.$

All input pulses are supplied by generators having the following characteristics:
 PRR ≤ 10 MHz; $Z_0 = 50 \Omega$; input slew rate = 1 V/ns $\pm 20 \%$, unless otherwise specified.

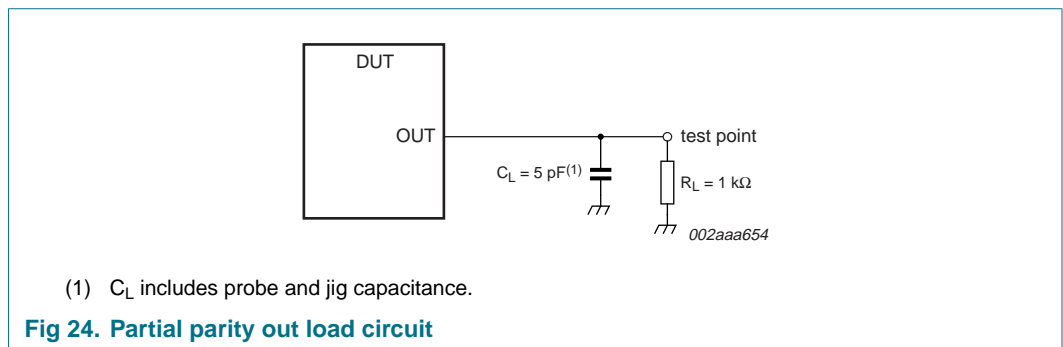

Fig 24. Partial parity out load circuit

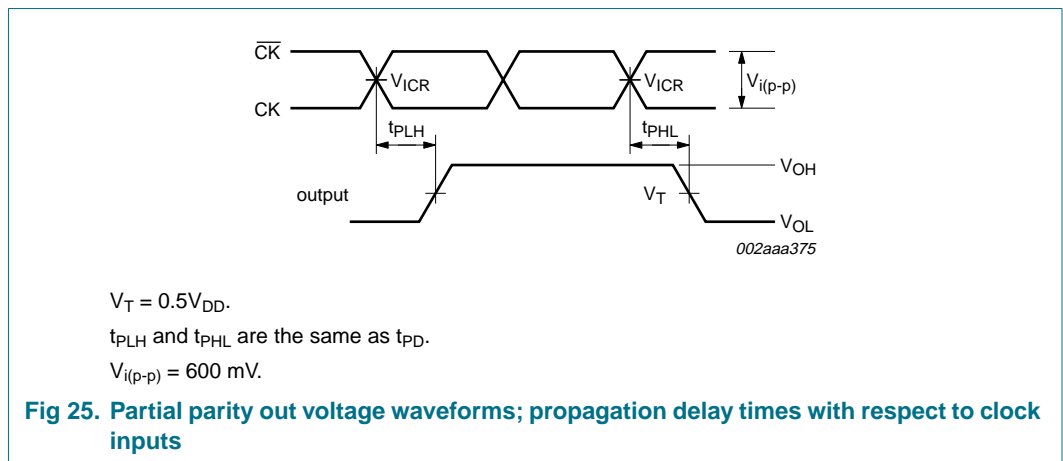
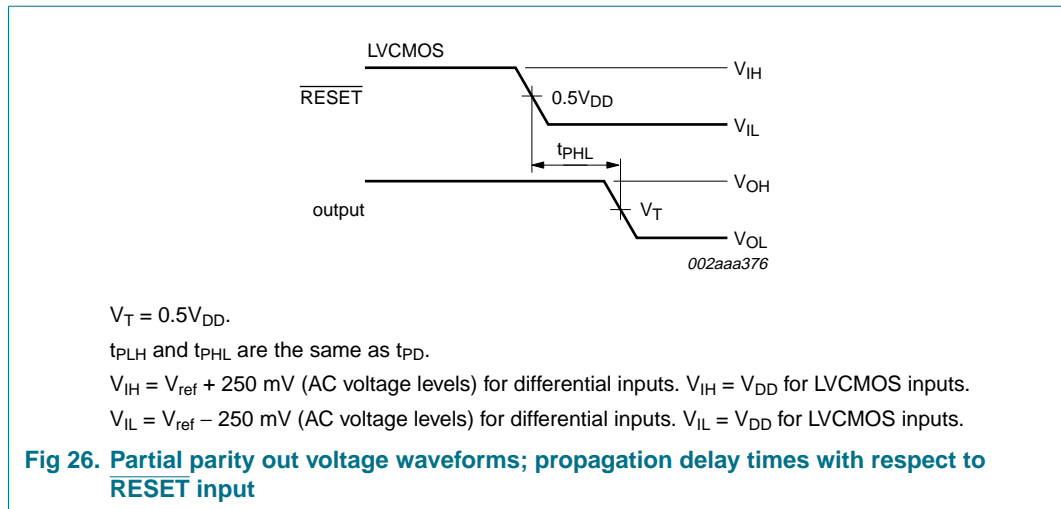

Fig 25. Partial parity out voltage waveforms; propagation delay times with respect to clock inputs



12. Package outline

LFBGA96: plastic low profile fine-pitch ball grid array package; 96 balls; body 13.5 x 5.5 x 1.05 mm SOT536-1

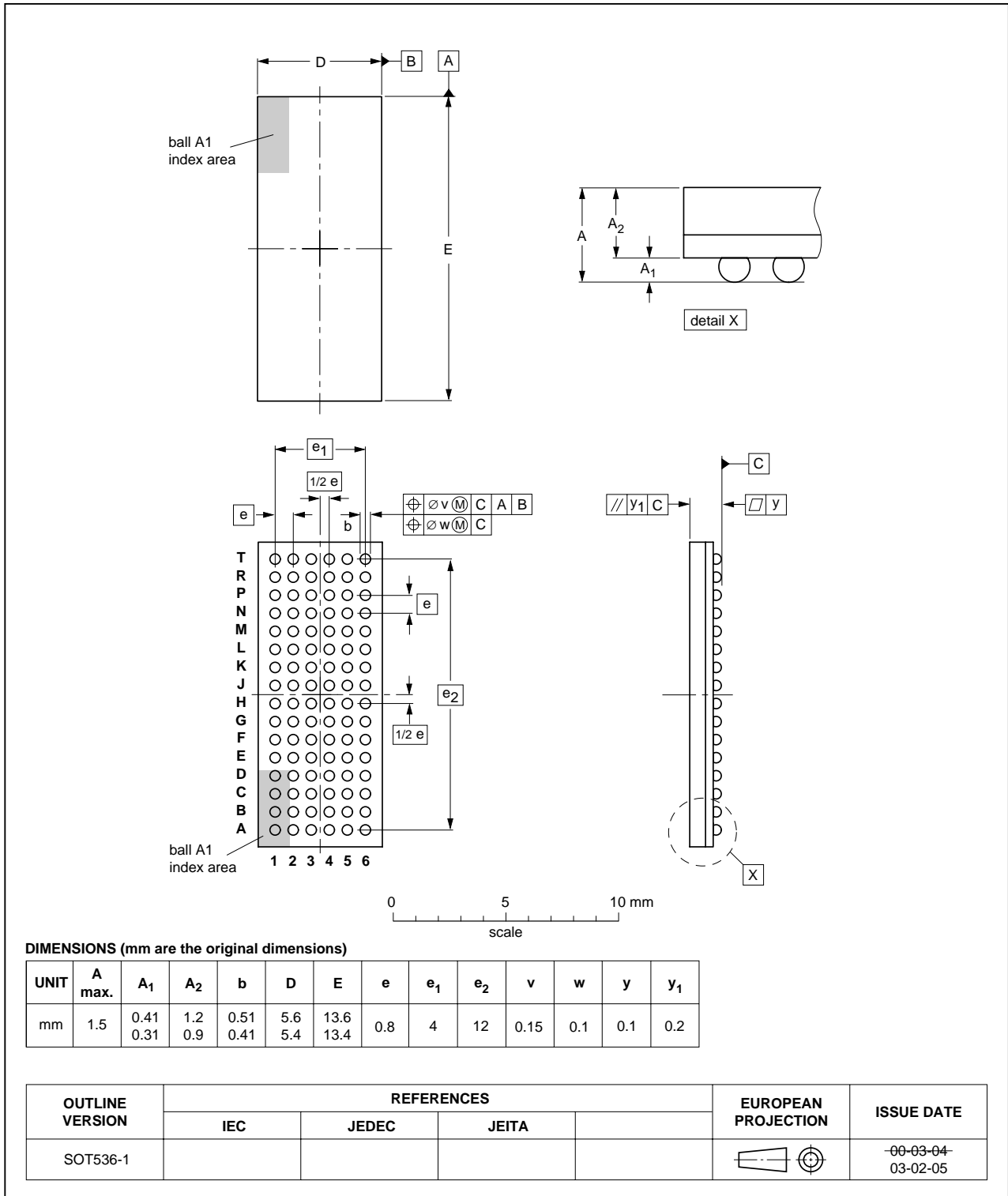

Fig 27. Package outline SOT536-1 (LFBGA96)

13. Soldering

This text provides a very brief insight into a complex technology. A more in-depth account of soldering ICs can be found in Application Note *AN10365 "Surface mount reflow soldering description"*.

13.1 Introduction to soldering

Soldering is one of the most common methods through which packages are attached to Printed Circuit Boards (PCBs), to form electrical circuits. The soldered joint provides both the mechanical and the electrical connection. There is no single soldering method that is ideal for all IC packages. Wave soldering is often preferred when through-hole and Surface Mount Devices (SMDs) are mixed on one printed wiring board; however, it is not suitable for fine pitch SMDs. Reflow soldering is ideal for the small pitches and high densities that come with increased miniaturization.

13.2 Wave and reflow soldering

Wave soldering is a joining technology in which the joints are made by solder coming from a standing wave of liquid solder. The wave soldering process is suitable for the following:

- Through-hole components
- Leaded or leadless SMDs, which are glued to the surface of the printed circuit board

Not all SMDs can be wave soldered. Packages with solder balls, and some leadless packages which have solder lands underneath the body, cannot be wave soldered. Also, leaded SMDs with leads having a pitch smaller than ~0.6 mm cannot be wave soldered, due to an increased probability of bridging.

The reflow soldering process involves applying solder paste to a board, followed by component placement and exposure to a temperature profile. Leaded packages, packages with solder balls, and leadless packages are all reflow solderable.

Key characteristics in both wave and reflow soldering are:

- Board specifications, including the board finish, solder masks and vias
- Package footprints, including solder thieves and orientation
- The moisture sensitivity level of the packages
- Package placement
- Inspection and repair
- Lead-free soldering versus PbSn soldering

13.3 Wave soldering

Key characteristics in wave soldering are:

- Process issues, such as application of adhesive and flux, clinching of leads, board transport, the solder wave parameters, and the time during which components are exposed to the wave
- Solder bath specifications, including temperature and impurities

13.4 Reflow soldering

Key characteristics in reflow soldering are:

- Lead-free versus SnPb soldering; note that a lead-free reflow process usually leads to higher minimum peak temperatures (see [Figure 28](#)) than a PbSn process, thus reducing the process window
- Solder paste printing issues including smearing, release, and adjusting the process window for a mix of large and small components on one board
- Reflow temperature profile; this profile includes preheat, reflow (in which the board is heated to the peak temperature) and cooling down. It is imperative that the peak temperature is high enough for the solder to make reliable solder joints (a solder paste characteristic). In addition, the peak temperature must be low enough that the packages and/or boards are not damaged. The peak temperature of the package depends on package thickness and volume and is classified in accordance with [Table 11](#) and [12](#)

Table 11. SnPb eutectic process (from J-STD-020C)

Package thickness (mm)	Package reflow temperature (°C)	
	Volume (mm ³)	
	< 350	≥ 350
< 2.5	235	220
≥ 2.5	220	220

Table 12. Lead-free process (from J-STD-020C)

Package thickness (mm)	Package reflow temperature (°C)		
	Volume (mm ³)		
	< 350	350 to 2000	> 2000
< 1.6	260	260	260
1.6 to 2.5	260	250	245
> 2.5	250	245	245

Moisture sensitivity precautions, as indicated on the packing, must be respected at all times.

Studies have shown that small packages reach higher temperatures during reflow soldering, see [Figure 28](#).

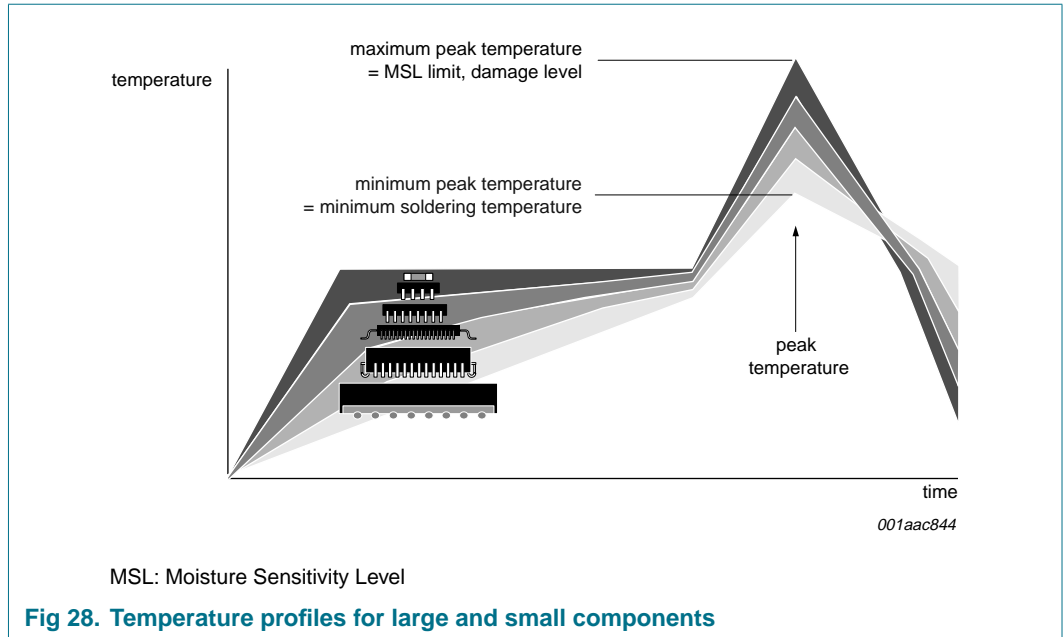

For further information on temperature profiles, refer to Application Note AN10365 “Surface mount reflow soldering description”.

14. Abbreviations

Table 13. Abbreviations

Acronym	Description
CMOS	Complementary Metal Oxide Silicon
DDR	Double Data Rate
DIMM	Dual In-line Memory Module
LVC MOS	Low Voltage Complementary Metal Oxide Silicon
PPO	Partial Parity Out
PRR	Pulse Repetition Rate
RDIMM	Registered Dual In-line Memory Module
SSTL	Stub Series Terminated Logic

15. Revision history

Table 14. Revision history

Document ID	Release date	Data sheet status	Change notice	Supersedes
SSTUA32866_2	20070326	Product data sheet	-	SSTUA32866_1
Modifications:	<ul style="list-style-type: none"> • The format of this data sheet has been redesigned to comply with the new identity guidelines of NXP Semiconductors. • Legal texts have been adapted to the new company name where appropriate. • 3rd paragraph, 2nd sentence of Section 7 “Functional description”: changed “... and CK going LOW.” to “... and \overline{CK} going LOW.” • Table 5 “Limiting values”: <ul style="list-style-type: none"> – changed Parameter for V_I to “input voltage”; moved “receiver” to Conditions – changed Parameter for V_O to “output voltage”; moved “driver” to Conditions – changed Parameter for I_O to “output current”; moved “continuous” to Conditions • Table 6 “Recommended operating conditions”: changed symbol “V_{TT}” to “V_T” • Table 7 “Characteristics”: <ul style="list-style-type: none"> – Symbol I_{DD}: changed Parameter to “supply current”; moved “static standby” and “static operating” to Conditions – I_{DD}, supply current, static standby: changed Max value from “100 μA” to “2 mA” – Symbol I_{DD}: changed Parameter to “dynamic operating current per MHz”; moved “clock only”, and “per each data input, 1 : 1 mode”, and “per each data input, 1 : 2 mode” to Conditions – Symbol C_i: changed Parameter to “input capacitance”; moved “data and \overline{CSR} inputs”, “CK and \overline{CK} inputs”, and “RESET input” to Conditions • Table 8 “Timing requirements”, Symbol t_W: changed Parameter to “pulse width”; moved “CK, \overline{CK} HIGH or LOW” to Conditions • Table 9 “Switching characteristics”: <ul style="list-style-type: none"> – changed Symbol “f_{MAX}” to “f_{max}” – changed Parameter for t_{PDM} to “peak propagation delay”; moved “single bit switching” to Conditions – changed Parameter for t_{PDMSS} to “simultaneous switching peak propagation delay” • (throughout data sheet): changed “$V_{DD}/2$” to “$0.5V_{DD}$” 			
SSTUA32866_1 (9397 750 14759)	20050715	Product data sheet	-	-

16. Legal information

16.1 Data sheet status

Document status ^{[1][2]}	Product status ^[3]	Definition
Objective [short] data sheet	Development	This document contains data from the objective specification for product development.
Preliminary [short] data sheet	Qualification	This document contains data from the preliminary specification.
Product [short] data sheet	Production	This document contains the product specification.

[1] Please consult the most recently issued document before initiating or completing a design.

[2] The term 'short data sheet' is explained in section "Definitions".

[3] The product status of device(s) described in this document may have changed since this document was published and may differ in case of multiple devices. The latest product status information is available on the Internet at URL <http://www.nxp.com>.

16.2 Definitions

Draft — The document is a draft version only. The content is still under internal review and subject to formal approval, which may result in modifications or additions. NXP Semiconductors does not give any representations or warranties as to the accuracy or completeness of information included herein and shall have no liability for the consequences of use of such information.

Short data sheet — A short data sheet is an extract from a full data sheet with the same product type number(s) and title. A short data sheet is intended for quick reference only and should not be relied upon to contain detailed and full information. For detailed and full information see the relevant full data sheet, which is available on request via the local NXP Semiconductors sales office. In case of any inconsistency or conflict with the short data sheet, the full data sheet shall prevail.

16.3 Disclaimers

General — Information in this document is believed to be accurate and reliable. However, NXP Semiconductors does not give any representations or warranties, expressed or implied, as to the accuracy or completeness of such information and shall have no liability for the consequences of use of such information.

Right to make changes — NXP Semiconductors reserves the right to make changes to information published in this document, including without limitation specifications and product descriptions, at any time and without notice. This document supersedes and replaces all information supplied prior to the publication hereof.

Suitability for use — NXP Semiconductors products are not designed, authorized or warranted to be suitable for use in medical, military, aircraft, space or life support equipment, nor in applications where failure or

malfunction of a NXP Semiconductors product can reasonably be expected to result in personal injury, death or severe property or environmental damage. NXP Semiconductors accepts no liability for inclusion and/or use of NXP Semiconductors products in such equipment or applications and therefore such inclusion and/or use is at the customer's own risk.

Applications — Applications that are described herein for any of these products are for illustrative purposes only. NXP Semiconductors makes no representation or warranty that such applications will be suitable for the specified use without further testing or modification.

Limiting values — Stress above one or more limiting values (as defined in the Absolute Maximum Ratings System of IEC 60134) may cause permanent damage to the device. Limiting values are stress ratings only and operation of the device at these or any other conditions above those given in the Characteristics sections of this document is not implied. Exposure to limiting values for extended periods may affect device reliability.

Terms and conditions of sale — NXP Semiconductors products are sold subject to the general terms and conditions of commercial sale, as published at <http://www.nxp.com/profile/terms>, including those pertaining to warranty, intellectual property rights infringement and limitation of liability, unless explicitly otherwise agreed to in writing by NXP Semiconductors. In case of any inconsistency or conflict between information in this document and such terms and conditions, the latter will prevail.

No offer to sell or license — Nothing in this document may be interpreted or construed as an offer to sell products that is open for acceptance or the grant, conveyance or implication of any license under any copyrights, patents or other industrial or intellectual property rights.

16.4 Trademarks

Notice: All referenced brands, product names, service names and trademarks are the property of their respective owners.

17. Contact information

For additional information, please visit: <http://www.nxp.com>

For sales office addresses, send an email to: salesaddresses@nxp.com

18. Contents

1	General description	1
2	Features	1
3	Applications	1
4	Ordering information	2
5	Functional diagram	2
6	Pinning information	4
6.1	Pinning	4
6.2	Pin description	6
7	Functional description	7
7.1	Function table	9
8	Limiting values	10
9	Recommended operating conditions	10
10	Characteristics	11
10.1	Timing diagrams	13
11	Test information	16
11.1	Parameter measurement information for data output load circuit	16
11.2	Data output slew rate measurement information	18
11.3	Error output load circuit and voltage measurement information	19
11.4	Partial parity out load circuit and voltage measurement information	20
12	Package outline	22
13	Soldering	23
13.1	Introduction to soldering	23
13.2	Wave and reflow soldering	23
13.3	Wave soldering	23
13.4	Reflow soldering	24
14	Abbreviations	25
15	Revision history	26
16	Legal information	27
16.1	Data sheet status	27
16.2	Definitions	27
16.3	Disclaimers	27
16.4	Trademarks	27
17	Contact information	27
18	Contents	28

Please be aware that important notices concerning this document and the product(s) described herein, have been included in section 'Legal information'.



© NXP B.V. 2007.

All rights reserved.

For more information, please visit: <http://www.nxp.com>

For sales office addresses, please send an email to: salesaddresses@nxp.com

Date of release: 26 March 2007

Document identifier: SSTUA32866_2