



Gravity: I2C Non-contact IR Temperature Sensor (MLX90614-DCI)

SKU:SEN0263

INTRODUCTION

We can divide temperature measurement into two types: contact and non-contact. Contact measurement can only accurately measure temperature when the testing object and the sensor reach thermal equilibrium. This can mean longer response times and reading inaccuracies offset by ambient temperature. By contrast, non-contact measurement uses infra-red radiation to measure the temperature and does not require a direct touch. Additionally, this method of measurement can be read quickly and accurately.

In recent years non-contact measurement methods have been used for medical, environmental monitoring, home automation, automotive electronic, aerospace and military applications.

Our latest infrared temperature measurement module is the MLX90614. This module measures the surface temperature by detecting infrared radiation energy and wavelength distribution. The IR temperature probe consists of an optical system, photoelectric detector, amplifier, signal processing and output module. The optical system collects the infrared radiation in its field of view and the infrared radiation energy is converted in to corresponding electrical signals when converging on the photoelectric detector. After being processed by the amplifier and signal processing circuit, the signal is converted in to a temperature value. The MLX90614 is self calibrating and has a low noise amplifier integrated in to the signal processing chip. The chip itself is a 17-bit ADC and DSP device, giving accurate and reliable results.

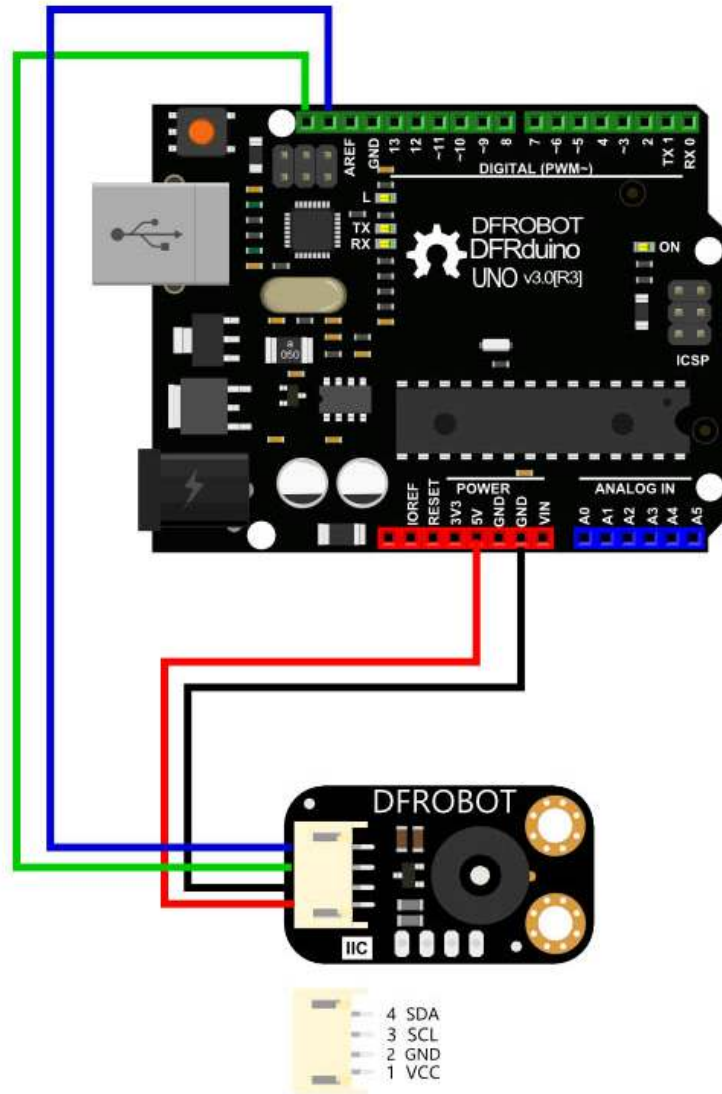

SEN0263 (MLX90614-DCI), due to its small field of view (FOV = 5°), is more suitable for industrial applications where the detection distance can be longer. In general applications, you can use SEN0206(MLX90614-BCC)

SPECIFICATION

- Model: MLX90614-DCI
- Operating Voltage: 3.3V - 5V
- Operating Current: 1.2mA
- Temperature: -70.01°C to +270°C, (0.01 °C resolution)
- Interface Type: I2C
- Interface Line Sequence: VCC, GND, SCL, SDA
- FOV: 5°
- Dimensions: 31.5*18 mm/1.24 x 0.7 inches
- Weight: 15g

