

STRAIGHT PLUG CLAMP TYPE

R114.009.000

CABLE 3.8/95 S

Series : SMB

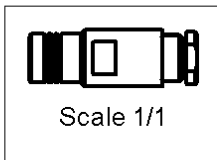
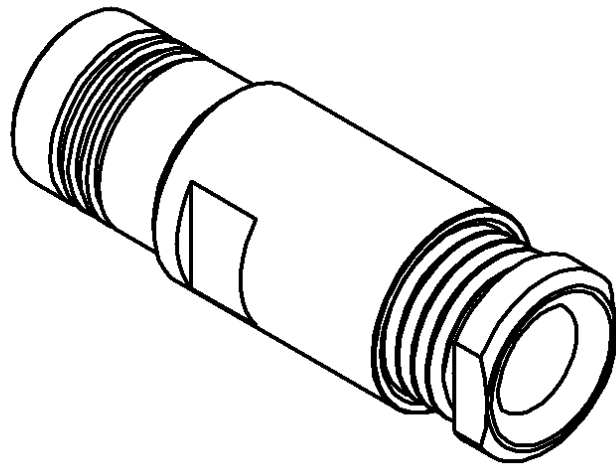
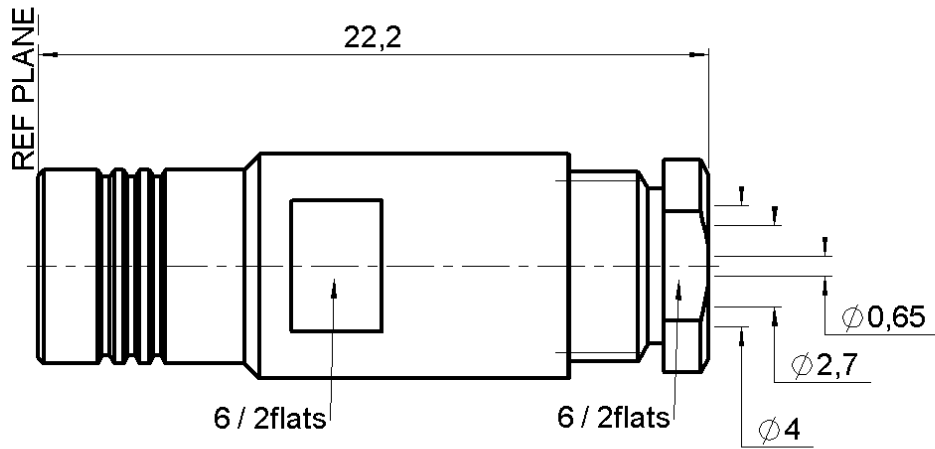

All dimensions are in mm.



COMPONENTS	MATERIALS	PLATINGS (µm)
BODY	BRASS	GOLD 0.2 OVER NICKEL 2
CENTER CONTACT	BERYLLIUM COPPER	GOLD 1.3 OVER NICKEL 2
OUTER CONTACT	BERYLLIUM COPPER	GOLD 0.5 OVER NICKEL 2
INSULATOR	PTFE	
GASKET	-	
OTHERS PARTS	BRASS	GOLD 0.2 OVER NICKEL 2
-	-	-
-	-	-

Issue : 0215 V

In the effort to improve our products, we reserve the right to make changes judged to be necessary.



STRAIGHT PLUG CLAMP TYPE**R114.009.000****CABLE 3.8/95 S**Series : **SMB****PACKAGING**

Standard	Unit	Other
100	'W' option	Contact us

SPECIFICATION**CABLE ASSEMBLY****ELECTRICAL CHARACTERISTICS**

Impedance		50 Ω
Frequency		0-4 GHz
VSWR	NA +	0.000 x F(GHz) Maxi
Insertion loss		NA √F(GHz) dB Maxi
RF leakage	- (57 - F(GHz)) dB mini
Voltage rating		335 Veff Maxi
Dielectric withstanding voltage		1000 Veff mini
Insulation resistance		1000 MΩ mini

Stripping	a	b	c	d	e	f
mm	2.50	1.20	4.50	4.50	0.00	0.00

Assembly instruction :

Recommended cable(s)

RG 180 BU

RG 195 AU

Cable retention

- pull off	150 N mini
- torque	NA N.cm

MECHANICAL CHARACTERISTICS

Center contact retention		
Axial force – Mating end	10 N mini	
Axial force – Opposite end	10 N mini	
Torque	NA N.cm mini	

TOOLING

Part Number	Description	Hexagon
.	.	.

OTHERS CHARACTERISTICS

Recommended torque		
Mating	NA N.cm	
Panel nut	NA N.cm	
Clamp nut	150 N.cm	
A/F clamp nut	6.000 mm	

Mating life	500 Cycles mini
Weight	3.811 g

ENVIRONMENTAL

Operating temperature	-65/+165 °C
Hermetic seal	NA Atm.cm ³ /s
Panel leakage	NA

Issue : **0215 V**

In the effort to improve our products, we reserve the right to make changes judged to be necessary.



STRAIGHT PLUG CLAMP TYPE

CABLE 3.8/95 S

R114.009.000

Series : SMB

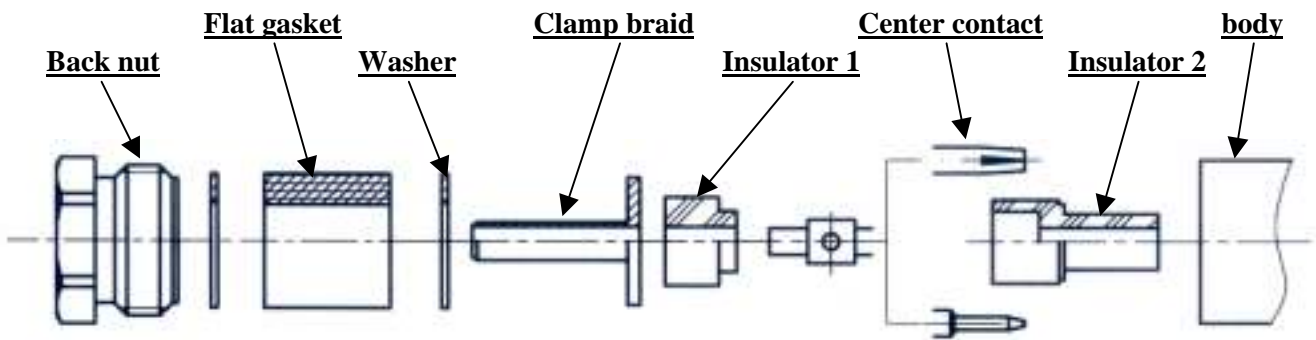
**1**

Slide the back nut, the first washer, the flat gasket, the second washer onto the cable.
Strip the cable.
Cut 2 slots in the jacket if necessary.

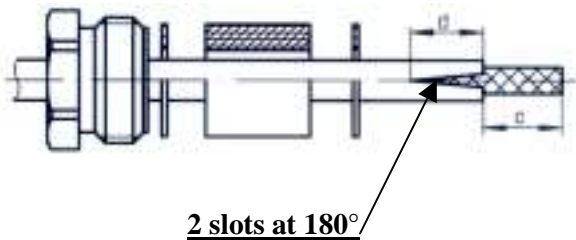
**3**

Slide the first insulator.
Slide the center contact and solder.
Slide the second insulator

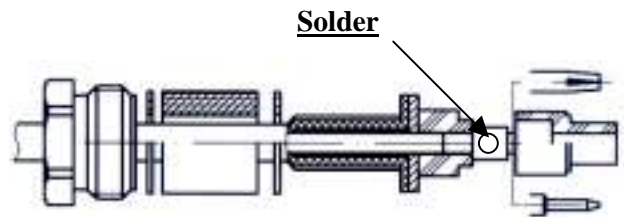
**2**

Slide the clamp braid sleeve.
Cut the braid flush with the clamp braid sleeve.
Strip off the diélectric.

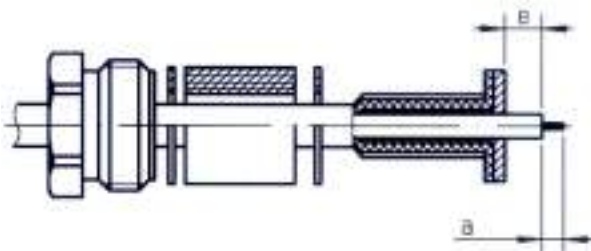
**4**

Screw sub-assembly into the connector body with the adapted wrench.

Recommended coupling torque (see connector TDS).

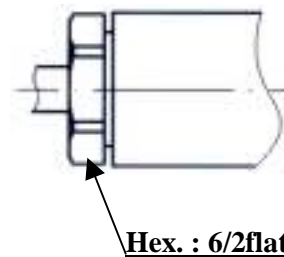

Issue : 0215 V

In the effort to improve our products, we reserve the right to make changes judged to be necessary.

