

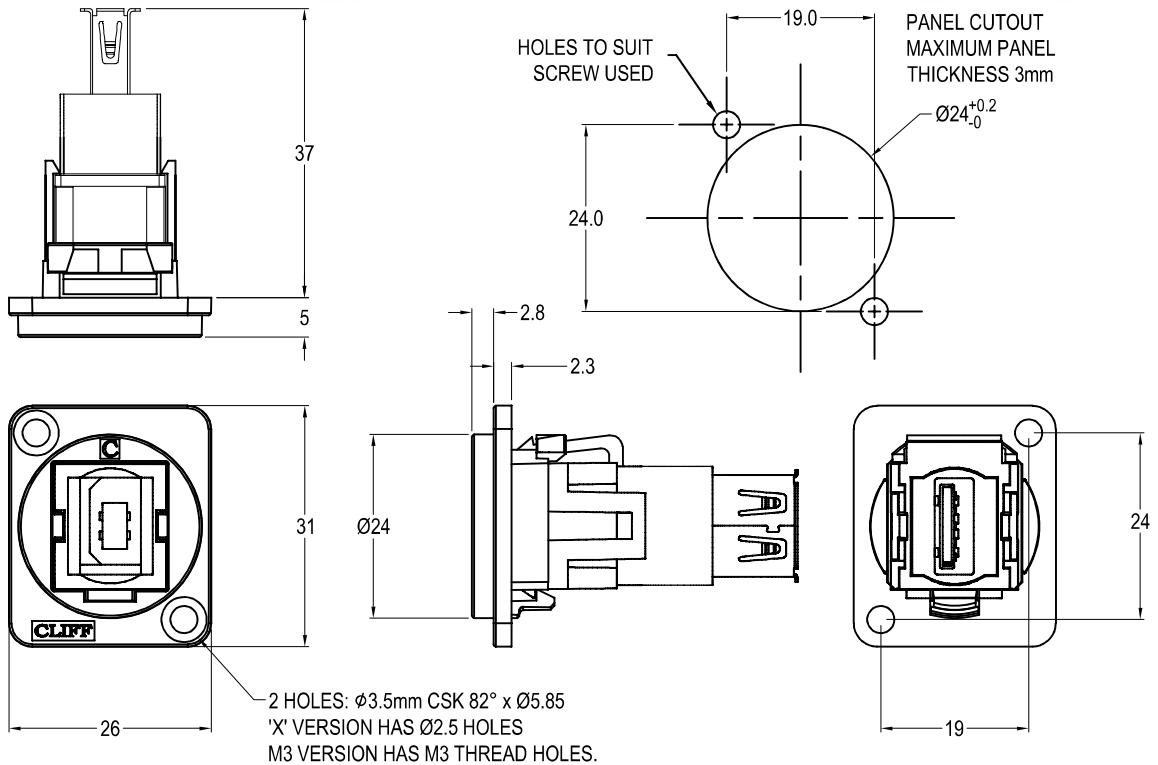

USB2.0 B-A FEEDTHROUGH CONNECTOR



Feedthrough Features

- Fits standard XLR Ø24mm cutout.
- No soldering or punch termination. Use standard cable for each connector style.
- Front or rear mounted.
- Low rear profile

General:

Please note: Functionality is affected by cable quality, length and cable wiring configuration.

Material:

1. Insert: ABS
2. Plastic Frame: Polyamide UL94 V2
3. Metal Frame: Diecast, Black or Nickel plated
4. Shell: Nickel plated steel
5. Contacts: Gold Plated

VARIANTS

Part No.

- | | |
|--------------------|---|
| CP30207N | USB2.0 B-A Black plastic frame, CSK holes |
| CP30207NW | USB2.0 B-A White plastic frame, CSK holes |
| CP30207NM | USB2.0 B-A Nickel plated metal frame, CSK holes |
| CP30207NM3 | USB2.0 B-A Nickel plated metal frame, M3 holes |
| CP30207NMB | USB2.0 B-A Black metal frame, CSK holes |
| CP30207NM3B | USB2.0 B-A Black metal frame, M3 holes |
| CP30207NX | USB2.0 B-A Black plastic frame, PLAIN holes |
| CP30207NXW | USB2.0 B-A White plastic frame, PLAIN holes |

Notes:

1. Voltage rating: 30V AC
2. Current rating: 1.5 A max
3. Contact resistance: 50mΩ max
4. Insulation resistance: 20MΩ min
5. Dielectric withstanding voltage: 500V AC
6. Operating Temperature: -20°C to 50°C