

**DESCRIPTION**

The LX1970 is a new technology light sensor with spectral response that emulates the human eye.

This device is ideal for monitoring ambient light for brightness control systems in flat panel displays. It has a unique photo diode arrangement (patents pending) with a peak response at 520 nm while sharply attenuating both ultra violet and infrared wavelengths.

The photo sensor is a PIN diode array with an accurate, linear, and very repeatable current transfer function.

Photo current is multiplied by integrated high gain amplifiers and is made available at two output pins; one a current source and the other a current sink.

These currents can easily be converted to voltage by adding a single resistor at either or both outputs. Voltage gain is determined by the resistor value typically in the 10K $\Omega$  to 50K $\Omega$  range.

With accurate internal gain amplifiers, design complexity and cost are greatly reduced.

The LX1970 is available in the 8-pin MSOP.

**IMPORTANT:** For the most current data, consult MICROSEMI's website: <http://www.microsemi.com>  
 Protected By U.S. Patents: 6,787,757; Patents Pending

**KEY FEATURES**

- Approximate Human Eye Spectral Response
- Low IR Sensitivity
- Highly Accurate & Repeatable Output Current vs. Light
- Voltage Scalable
- Temperature Stable
- Integrated High Gain Photo Current Amplifiers
- Complementary Current Outputs
- No Optical Filters Needed

**APPLICATIONS**

- PDA
- Notebook PC
- LCD TV
- Tablet PC
- Cell phones

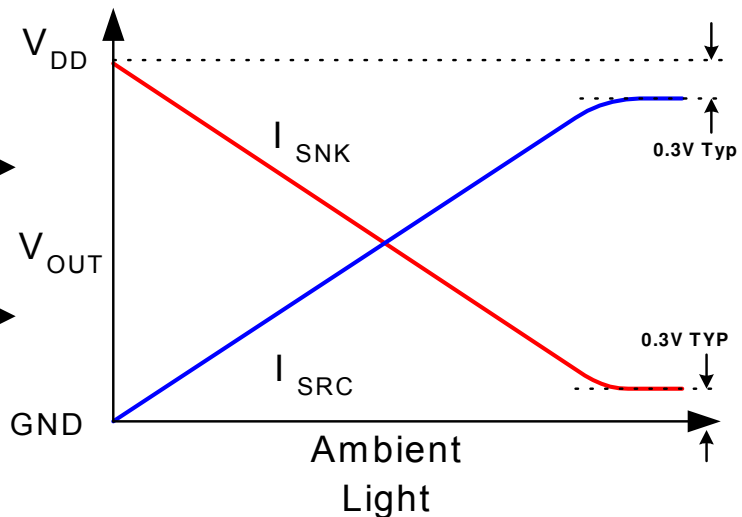
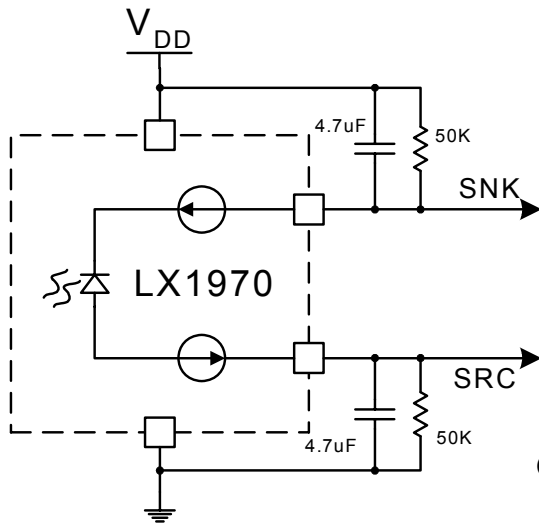
**PRODUCT HIGHLIGHT**

**PACKAGE ORDER INFO**

$T_A$ (°C)	<b>DU</b> Plastic MSOP
	8-Pin
	RoHS Compliant / Pb-free
-40 to 85	<b>LX1970IDU</b>

Note: Available in Tape & Reel. Append the letters "TR" to the part number. (i.e. LX1970IDU-TR)

**ABSOLUTE MAXIMUM RATINGS**

$V_{DD}$ .....	-0.3 to 6 $V_{DC}$
SNK/SRC (Output Compliance Voltage).....	-0.3 to $V_{DD} + 0.3V_{DC}$
SNK/SRC (Maximum Output Current).....	Internally Limited
Operating Temperature Range .....	-40 to +85°C
Storage Temperature Range .....	-40 to +100°C
Solder Reflow Peak Temperature (40 seconds maximum exposure).....	260°C (+0, -5)

Notes: Exceeding these ratings could cause damage to the device. All voltages are with respect to Ground. Currents are positive into, negative out of specified terminal.

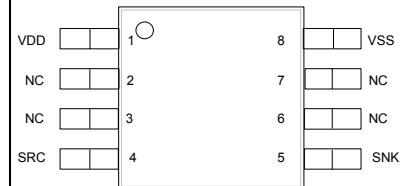
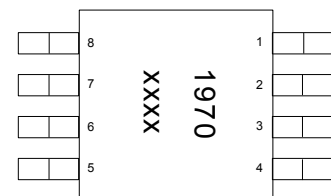
**PACKAGE PIN OUT**

**DU PACKAGE**  
 (Top View)

**DU PACKAGE**  
 (Bottom View)

xxxx = Denotes Date Code / Lot Information

RoHS / Pb-free NiPdAu Pin Finish  
 MSL 2 / 260°C / 1 Year

**THERMAL DATA**
**DU** Plastic MSOP 8-Pin

THERMAL RESISTANCE-JUNCTION TO AMBIENT, $\theta_{JA}$	<b>206°C/W</b>
THERMAL RESISTANCE-JUNCTION TO CASE, $\theta_{JC}$	<b>39°C/W</b>

**FUNCTIONAL PIN DESCRIPTION**

NAME	DESCRIPTION
$V_{DD}$	Input Supply Voltage
$V_{SS}$	Ground Reference for Power and Signal Output
SNK	Output Current Sink
SRC	Output Current Source

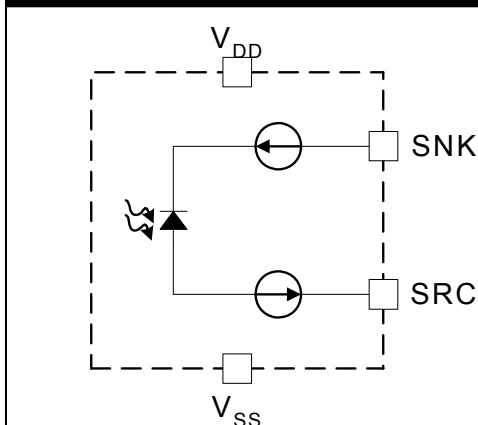
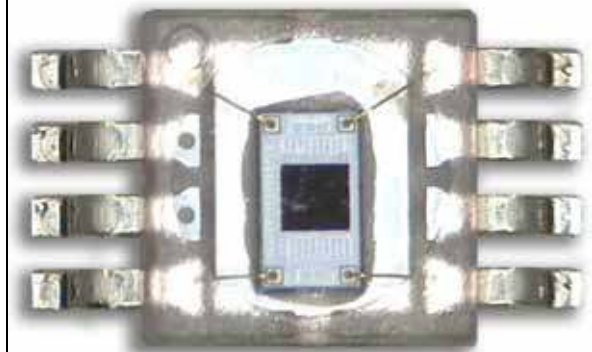
**SIMPLIFIED BLOCK DIAGRAM**

**PACKAGE PHOTO**

**RECOMMENDED OPERATING CONDITIONS**

Parameter	LX1970			Units
	Min	Typ	Max	
Supply Voltage ( $V_{DD}$ )	2 <sup>1</sup>		5.5	V
SNK Compliance Voltage Range	$V_{SS} + 0.5$		$V_{DD}$	V
SRC Compliance Voltage Range	$V_{SS}$		$V_{DD} - 0.5$	V
SNK/SRC Output Resistor Range	10		1000	K $\Omega$

Note 1: SRC output will work down to  $V_{DD}=1.8V$

**ELECTRICAL CHARACTERISTICS**

Unless otherwise specified, the following specifications apply over the operating ambient temperature  $-40^{\circ}C \leq T_A \leq 85^{\circ}C$ ,  $V_{DD} = 2V$  to  $5.5V$ ,  $R_{LOAD} = 50K\Omega$ , Direct Light Input<sup>2</sup> of  $14.6\mu W/cm^2$  except where otherwise noted. Performance between  $-40^{\circ}C$  and  $0^{\circ}C$  and between  $70^{\circ}C$  and  $85^{\circ}C$  are assured by design and characterization.

Parameter	Symbol	Test Conditions	LX1970			Units
			Min	Typ	Max	
Supply Voltage Range	$V_{DD}$		2		5.5	$V_{DC}$
Input Supply Current	$I_{DD}$	$V_{DD} = 3.0V$ , $I_{SRC} = 38\mu A$ , $I_{SNK} = \text{open}$	60	85	110	$\mu A$
Output Current <sup>3</sup>	$I_{SRC}$	$V_{DD} = 3.0V$	30	38	46	$\mu A$
	$I_{SNK}$	$V_{DD} = 3.0V$	-30	-38	-46	$\mu A$
Output SNK/SRC Current Matching	$I_{MATCH}$	$V_{DD} = 3.0V$		0.5	2	%
SNK Minimum Compliance Voltage	$SNK_{VMIN}$	$V_{DD} = 3.0V$ , @ 95% of nominal output current		$V_{SS} + 0.3$	$V_{SS} + 0.5$	V
SRC Maximum Compliance Voltage	$SRC_{VMAX}$	$V_{DD} = 3.0V$ , @ 95% of nominal output current		$V_{DD} - 0.3$	$V_{DD} - 0.5$	V
SNK/SRC Output Dark Current	$I_{DARK}$	$V_{DD} = 5.5V$ , No Light		10	300	nA
Wavelength of Peak Sensitivity	$\lambda_{PS}$			520		nm
Half Reception Angle	$\theta_{\frac{1}{2}}$			$\pm 60$		deg
Supply Voltage Coefficient of Output Current	PSRR	$V_{DD} = 2V$ to $5.5V$		2.2	5	%/V
Sensitivity @ 540nm (peak)		Irradiance current responsivity		2.6		A/(W/cm <sup>2</sup> )
Sensitivity Change @ 910nm <sup>4</sup>		Current responsivity change with additional direct light input of $14.6\mu W/cm^2$ at 910nm	-5	0	5	% of peak
Radiant Sensitive Area		Photodiode area		0.369		mm <sup>2</sup>

Note 2: The input irradiance is supplied from a white light-emitting diode (LED) optical source adjusted to impose  $14.6\mu W/cm^2$  at 555nm on the sensor's surface.

Note 3: See Figure 1

Note 4: See Figure 2

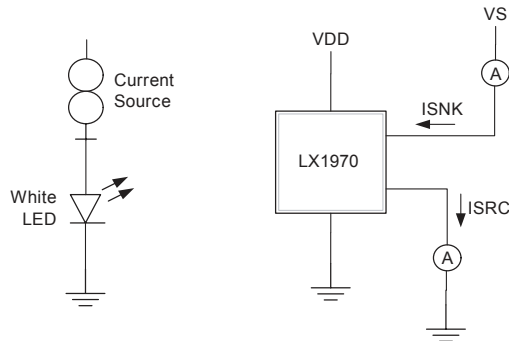
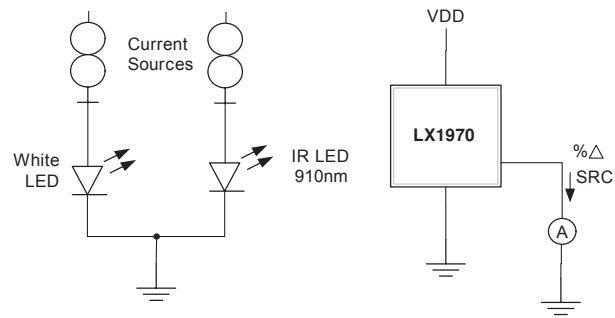
**MEASUREMENT CIRCUIT CONFIGURATIONS**

**Figure 1 – Light Current Measurement Circuit**

**Figure 2 – IR sensitivity Measurement Circuit**
**APPLICATION NOTES**
**LIGHT UNITS**

In converting from  $\mu\text{W}/\text{cm}^2$  to Nits it is necessary to define the light source. Nits are units for a measurement of luminance, which is the apparent brightness of an illuminated flat surface.  $\mu\text{W}/\text{cm}^2$  is a measurement of irradiance or the measurement of electromagnetic radiation flux both visible and invisible. The first step in the conversion process is to convert irradiance to illuminance, which essentially involves running the irradiant flux through a photopic filter. In normal ambient a photopic curve is used and in dark ambient a scotopic curve (dark adapted eye) is used. If the light is composed of only one wavelength, a conversion chart will tell the conversion factor to convert  $\mu\text{W}/\text{m}^2$  to lux (lumens/ $\text{m}^2$ ). If more than one wavelength is used, the light spectrum of the irradiance must be applied to the photopic filter to determine the resultant illuminance. The most sensitive wavelength for the normal light adapted human eye is 555nm. At 555nm, the conversion factor is  $683 \text{ Lux} = 1 \text{ W}/\text{m}^2 = 100 \mu\text{W}/\text{cm}^2$ . Therefore  $14.6 \mu\text{W}/\text{cm}^2 = 100 \text{ lux}$  at 555nm.

The next step in the conversion process is to convert illuminance to luminance. The units for illuminance are lux or lumens/ $\text{m}^2$ . The units for luminance are Nits or lumens/ $\text{m}^2/\text{steradian}$ . Assuming the illuminance falls on a Lambertian surface which has perfect dispersion and total reflection, the conversion from lux to nits is 3.14 lux falling on a Lambertian reflector produces 1 Nit. Therefore 100 Lux will produce 31.4 Nits.

If the photo sensor had a truly photopic response, it would produce the same output current for the same number of nits or lux, regardless of the color of the light. However, because the match is not perfect, there is still wavelength dependency particularly at the ends of the visible spectrum.

In the case of the LX1970 the peak photo response is at 520nm, however depending on the light source, what the human eye perceives as 'white' light may actually be composed of peak wavelengths of light other than 520nm. For instance a typical fluorescent lamp includes dominant light not only near 550nm but also at 404 and 435nm. Incandescent light sources such as standard tungsten lights generate substantial IR radiation out beyond 2000nm.

**APPLICATION INFORMATION**

The LX1970 is a light sensor with a spectral response that resembles the human visual system. It is packaged in clear MSOP package. Microsemi also offers the LX1971 with the same pin out and similar supply voltage range as LX1970 light sensor. The LX1971 responsiveness however differs from that of the LX1970. In general the LX1971 has lower sensitivity and a wider dynamic range.

The LX1970 has a responsiveness that is directly proportional to the intensity of light falling on the photo receptors. Although the gain varies depending on the wavelength of the light and the direction of light, in general for a 555nm wavelength (yellow-green), the sensitivity is:

$$I_{OUT} = L \times 0.76 \mu A \quad \text{for } L < 1200 \text{ lux}$$

The LX1970 is best suited for applications where the light sensor is an integral part of a continuous lighting control system. For example, in an LCD backlighting application, the level of brightness of the backlight should be adjusted in proportion to the level of ambient lighting; the LX1970 can provide closed loop brightness control for this type of system. For most indoor applications, the 1200 lux saturation point of the LX1970 is usually not a limiting affect.

The LX1971 is best suited for applications where the system must respond to external events that affect the user's ability to see clearly. For example, a sensor to turn on headlights or a sensor to adjust the reflectivity of a rear view mirrors. These systems require the sensor to have dynamic range similar to sight. Like the human eye, the square root function of the LX1971 makes it extra sensitive to small changes at lower light levels. The wide dynamic range allows the LX1971 to sense the difference between twilight and daylight or sunshine and heavy cloud cover.

The first curve shows the calculated responsiveness of the LX1970 without load resistors based on the formula above. It can be used as baseline guidelines to calculate gain setting resistors. The compliance of the current source output may result in premature saturation of the output when load resistors are added. The SRC compliance voltage is specified typically at VDD-350mV @ about 100 lux. The second curve shows saturation of the output with  $V_{IN} = 5V$  and a 10K resistor SRC to ground, above about 300uA the output becomes non-linear as it begins to saturate.

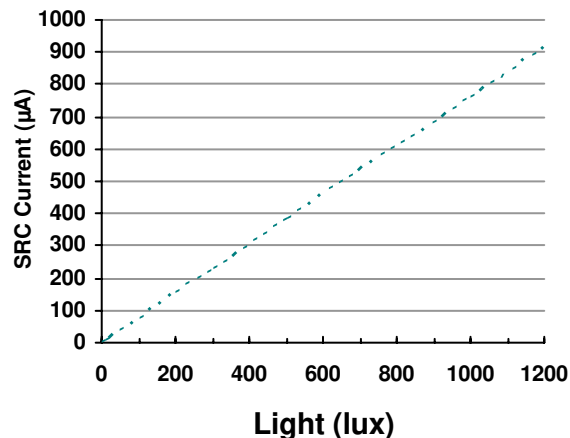
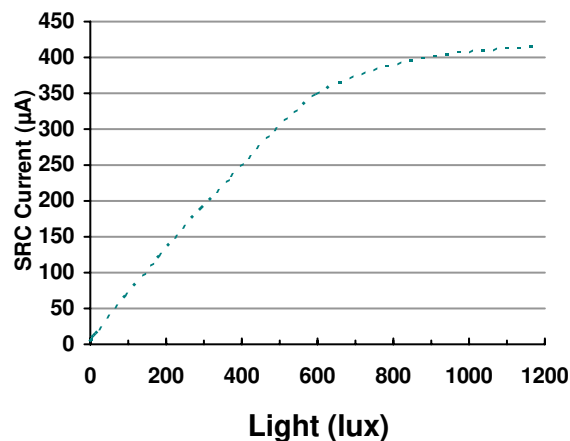
**LX1970 Calculated SRC Full Range Response**

**LX1970 SRC Actual SRC with 10K Resistor**

**APPLICATION EXAMPLES**

The following examples present both fully automatic (no user input) and semi-automatic to fully manual override implementations. These general guidelines are applicable to a wide variety of potential light control applications. The LX1970 can be used to control the brightness input of CCFL inverters (like Microsemi's PanelMatch™ inverter family, or line of controller IC's). Likewise it can interface well with LED drivers like the LX1990 and LX1991 sink LED drivers, or boost drivers like the LX1992 and LX1993.

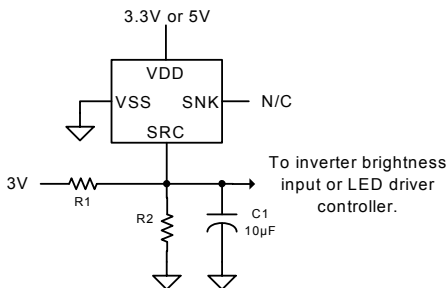
In each specific application it is important to recognize the need to correlate the sink and source current of the LX1970 for the target environment and its ambient light conditions. The mechanical mounting of the sensor, light aperture hole size, use of a light pipe or bezel are critical in determining the response of the LX1970 for a given exposure of light.

**Figure 2**

The example in figure 2 shows a fully automatic dimming solution with no user interaction. Choose R1 and R2 values for any desired minimum brightness and slope. Choose C1 to adjust response time and filter 50/60 Hz room lighting. As an example, let's say you wish to generate an output voltage from 0.25V to 1.25V to drive the input of an LED driver controller. The 0.25V represents the minimum LED brightness and 1.25V represents the maximum. The first step would be to determine the ratio of R1 and R2.

$$R1 = R2 \left[ \frac{3.0V}{0.25V} - 1 \right] = 11 \times R2$$

Next the value of R2 can be calculated based on the maximum output source current coming from the LX1970 under the application's maximum light exposure, let's say this has been determined to be about 50µA. Thus R2 can be calculated first order as follows:

$$R2 = \left[ \frac{1.25V}{50\mu A} \right] = 25K\Omega \therefore R1 = 11 \times R2 = 275K\Omega$$

The output node will actually reach 1.25V when the source current from the LX1970 is only about 44µA since about 6µA of current will be contributed from R1. This assumes a high impedance input to the LED driver. In Figure 3 user adjustable bias control has been added to allow control over the minimum and maximum output voltage. This allows the user to adjust the output brightness to personal preference over a limited range. The PWM input source could of course be replaced with an equivalent DC voltage.

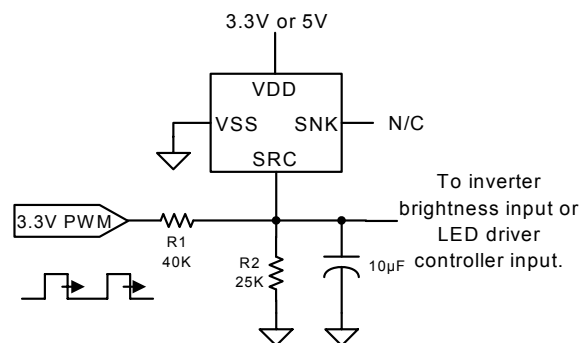
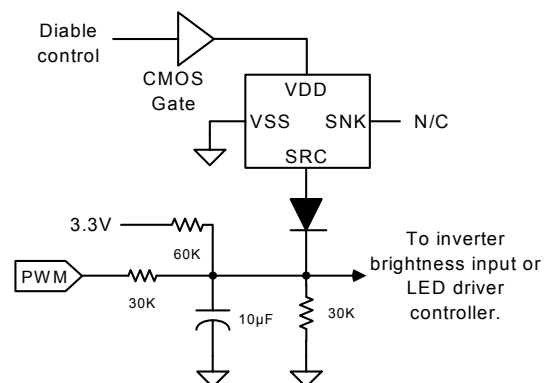
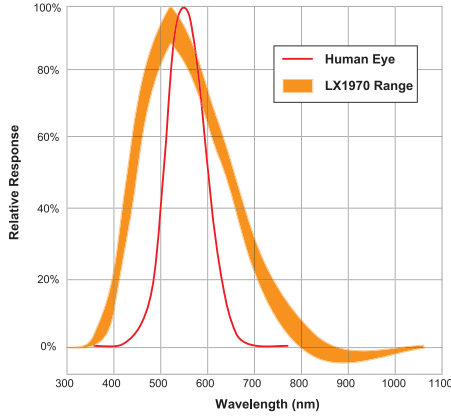

**Figure 3**

Figure 4 shows how a fully manual override can be quickly added to the example in figure 3. In addition to the gate to turn on and off the LX1970, a diode has been inserted to isolate the LX1970 when it is shut down.

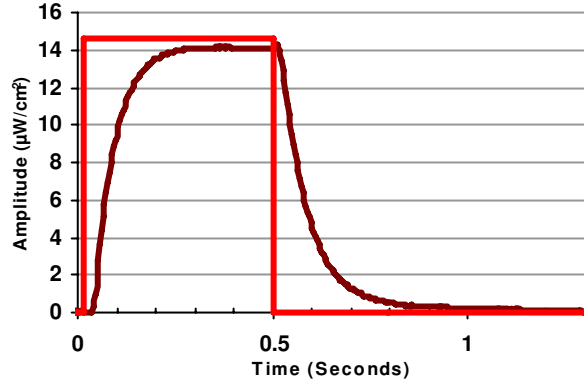

**Figure 4**

The preceding examples represent just a few of the many ways the sensor can be used. For example since there is also a complimentary sink output a resistor from VDD to SNK could develop a voltage that could be compared (with some hysteresis) to a fixed reference voltage and develop a logic shutdown signal. If the application is utilizing a transfective or reflective LCD display such a signal could disable the backlight or front light to the display when reaching sufficient ambient light.

**RESPONSE VS WAVELENGTH**



**I<sub>SNK</sub> STEP RESPONSE**



Load = 10kΩ and 1μF  
Photo Step = Direct Light Input of 14.6μW/cm²

**SMALL SIGNAL FREQUENCY RESPONSE**

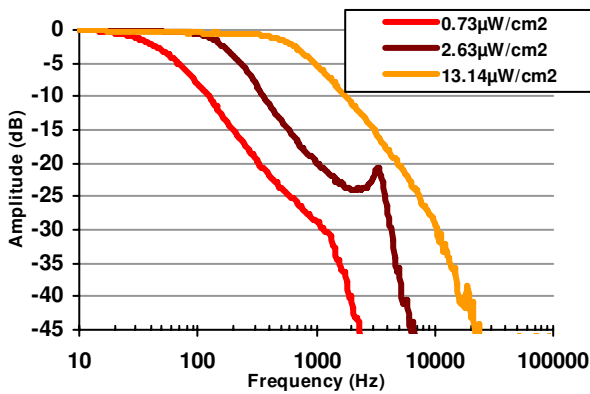

V<sub>DD</sub> = 3.0V, SNK, Three Light Levels, No Filtering

**DARK CURRENT VS TEMP**

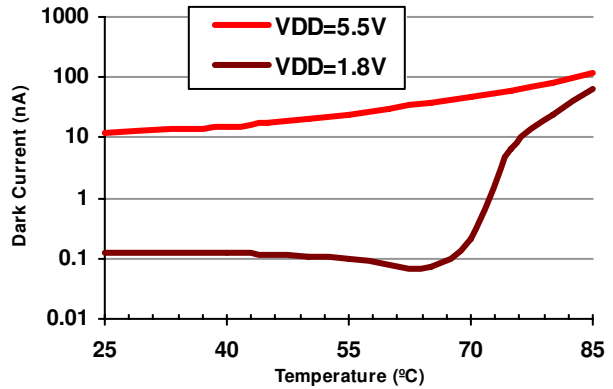

**SNK OUTPUT PSRR**

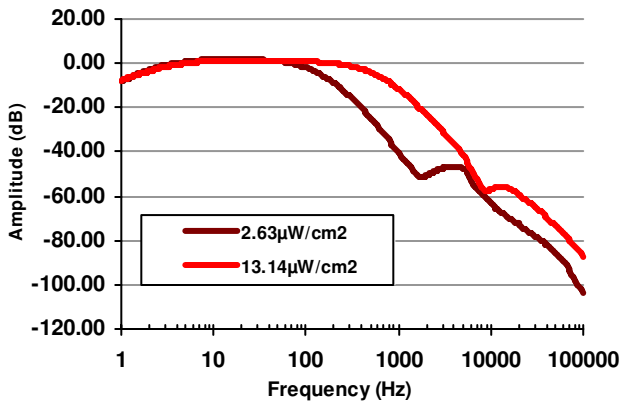

V<sub>DD</sub> = 3.0V  
Load = 10kΩ and 1μF to Ground

**GAIN VS TEMP**

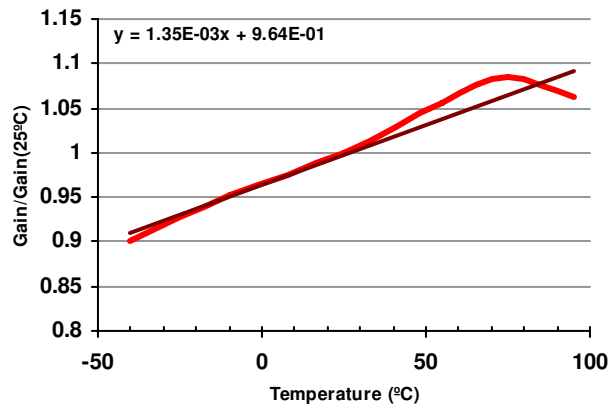

V<sub>DD</sub> = 3.0V  
Direct Light Input of 13.14μW/cm²

**VERTICAL DIRECTION RESPONSE**

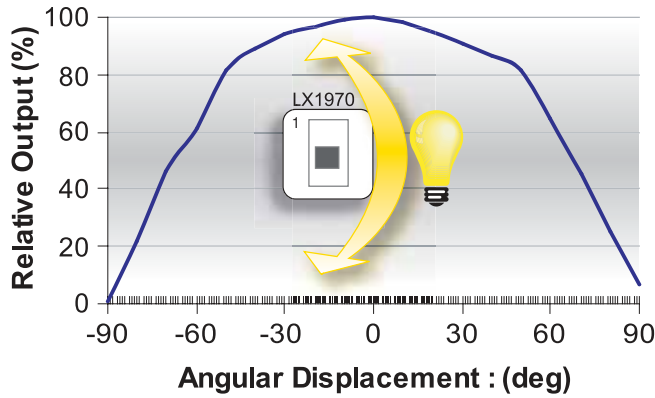

**HORIZONTAL DIRECTION RESPONSE**

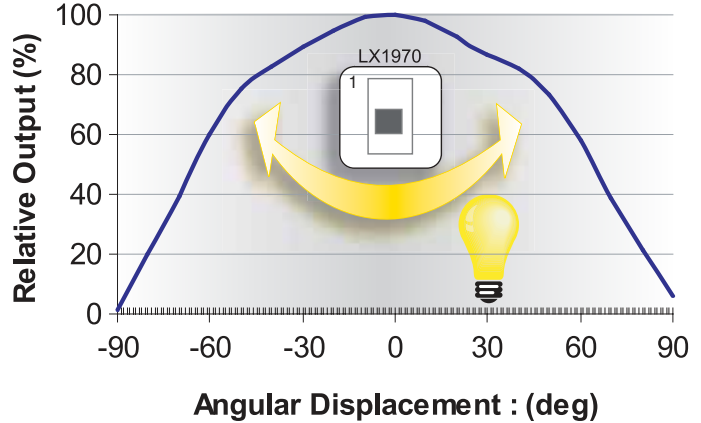

**SNK COMPLIANCE VS CURRENT**

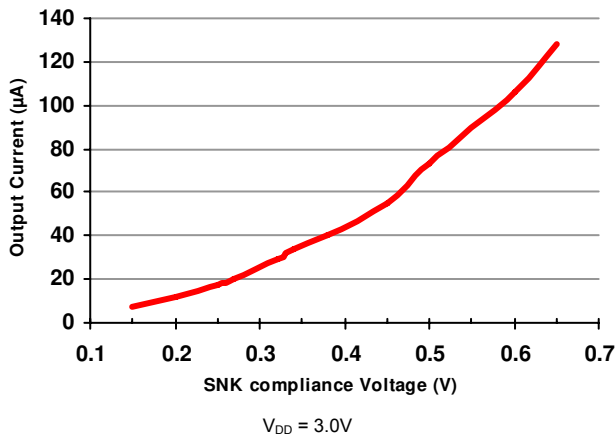

**SRC COMPLIANCE VS CURRENT**

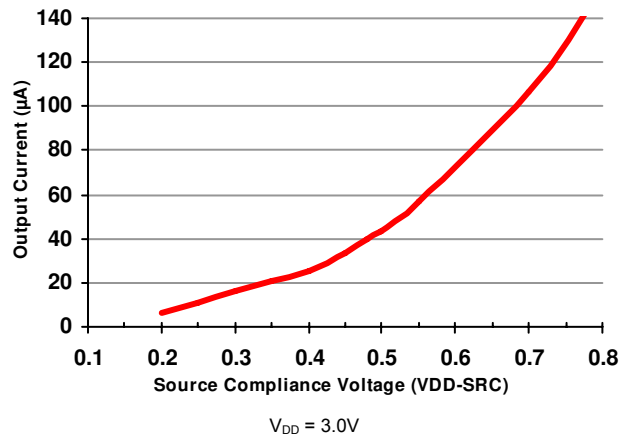

**SRC CURRENT VS LIGHT (LUX)**

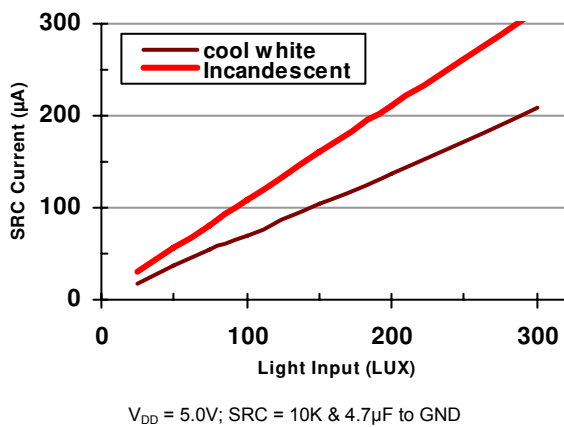

**TYPICAL LOW AMBIENT RESPONSE**

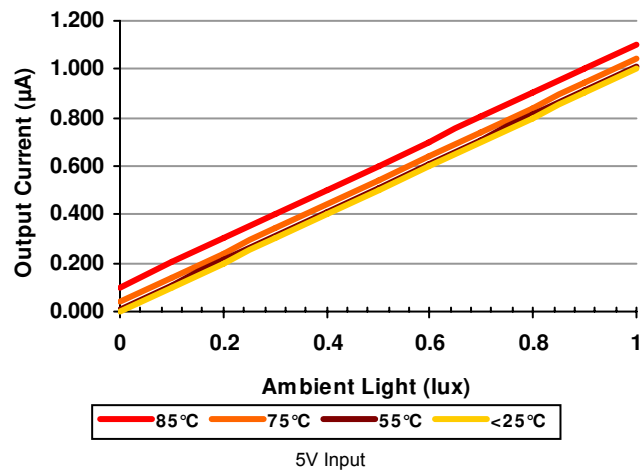

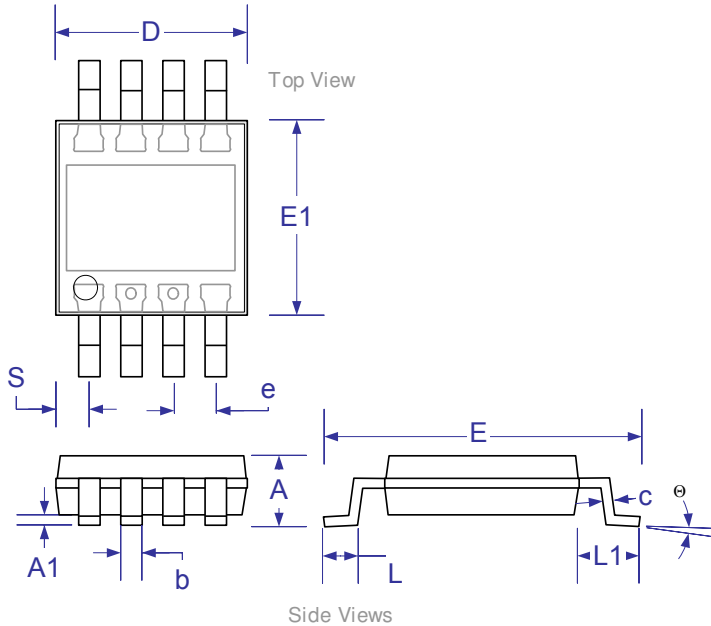

**PACKAGE DIMENSIONS**
**DU 8-Pin Miniature Shrink Outline Package (MSOP)**

Dim	MILLIMETERS		INCHES	
	MIN	MAX	MIN	MAX
A	–	1.10	–	0.043
A1	0.05	0.15	0.002	0.006
b	0.26	0.41	0.010	0.016
c	0.13	0.23	0.005	0.009
D	2.90	3.10	0.114	0.122
e	0.65 BSC		0.025 BSC	
E	4.75	5.05	0.187	0.198
E1	2.90	3.10	0.114	0.122
L	0.41	0.71	0.016	0.028
L1	0.95 BSC		0.037 BSC	
S	0.525 BSC		0.021 BSC	
θ	3°		3°	

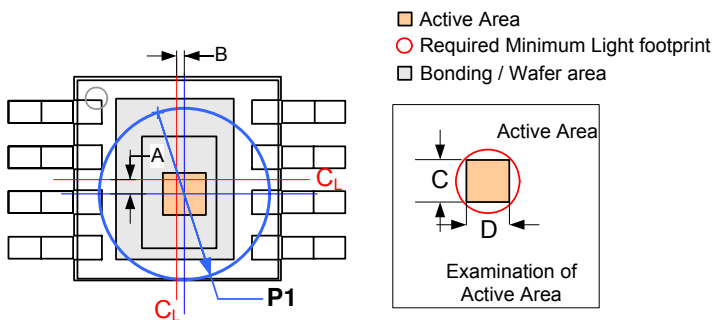

Dim	MILLIMETERS		INCHES	
	MIN	MAX	MIN	MAX
A	0.225		0.0088	
B	0.145		0.0057	
C	0.600		0.0236	
D	0.612		0.0241	
P1	2.5		0.98	

**Note:**

CL is the center of the package

P1 represents a possible light footprint and its dimensions are not subject to strict tolerances. Only the active area of the device is required to be covered with light. This larger footprint is designed to ensure coverage of the device's active area.

**NOTES**

PRODUCTION DATA – Information contained in this document is proprietary to Microsemi and is current as of publication date. This document may not be modified in any way without the express written consent of Microsemi. Product processing does not necessarily include testing of all parameters. Microsemi reserves the right to change the configuration and performance of the product and to discontinue product at any time.