

This drawing is the property of Tusonix, Inc., and may not be used, reproduced, published or disclosed to others without expressed authorization by Tusonix Inc.

**MARKETING SALES DRAWING**  
**DIMENSIONS IN INCHES - DO NOT SCALE THIS DRAWING**  
**DIMENSIONS IN METRIC - [ ]**

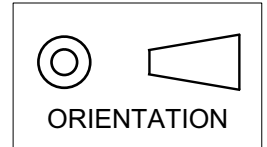

**Electrical Testing**  
**per Tusonix standard**  
**test plans and Mil-Std-202**  
**Test Methods.**

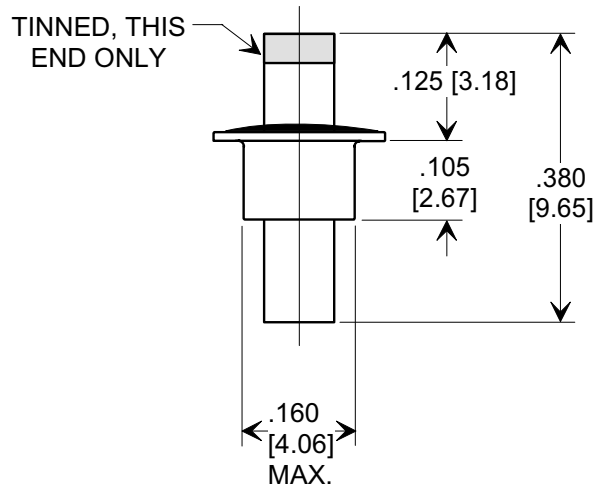
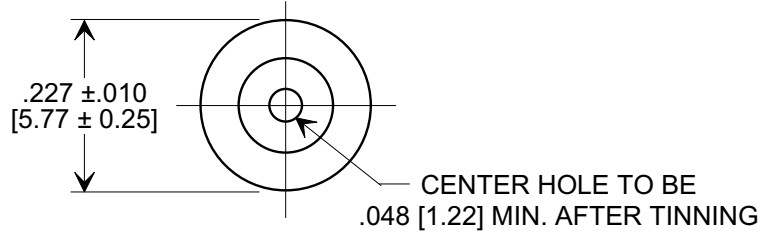
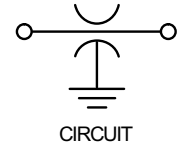

**NOTES:**

- TUSONIX STANDARD PART NUMBER: 2404-014-X5U0-102P. TUSONIX RoHS COMPLIANT PART NUMBER: 2404-014-X5U0-102P LF. CUSTOMER MUST SPECIFY STANDARD OR RoHS PART NUMBER WHEN ORDERING.
- EYELET FINISH: STANDARD PART -60/40 SOLDER PLATED, RoHS PART - SILVER PLATED.
- PART MARKING: STANDARD PART - 3 DOT COLOR CODE, RoHS PART- ADDITIONAL GREEN DOT IDENTIFIER.

**SPECIFICATIONS**

Style No.:	2404-014
Capacitance:	1000 pF
Tolerance:	+100 / -0%
Temp. Coef.:	X5U
Operating Temp.:	-55°C TO + 85°C
Voltage Rating:	500 VDC

<b>REVISION RECORD</b> Original Release C.O. ECO-659	<b>A</b>	<b>--TOLERANCES--</b> Unless Otherwise Specified	Title <b>FEED - THRU CAPACITOR</b>	
	<b>DECIMAL ± .015 [0.38]</b>			
	<b>ANGLES ±</b>	Drawn <b>L.E. 04-14-09</b>	Scale <b>4 X</b>	
	<b>TUSONIX</b> TUCSON, ARIZONA	Approved <b>R.L. 04-14-09</b>	<b>A 2404-014-X5U0-102P</b>	