



Electrical specifications

Center Frequency: 387 MHz
Bandwidth: 225 MHz
Passband: 275-500 MHz
Insertion Loss: 3 dB Max
Return Loss: 15 dB Min
Rejection: >40 dB @ 245 MHz
>40 dB @ 550 MHz
Power Handling: 10 W

Mechanical

Dimensions: 4.0 x 0.6 x 0.5 inches
Connector Type: SMA (F)

Environmental

Operating Temperature: -55 to +85° C
Shock: 30 G. 11ms
Vibration: 10 G. 5 to 1000 Hz

Outline Drawing:

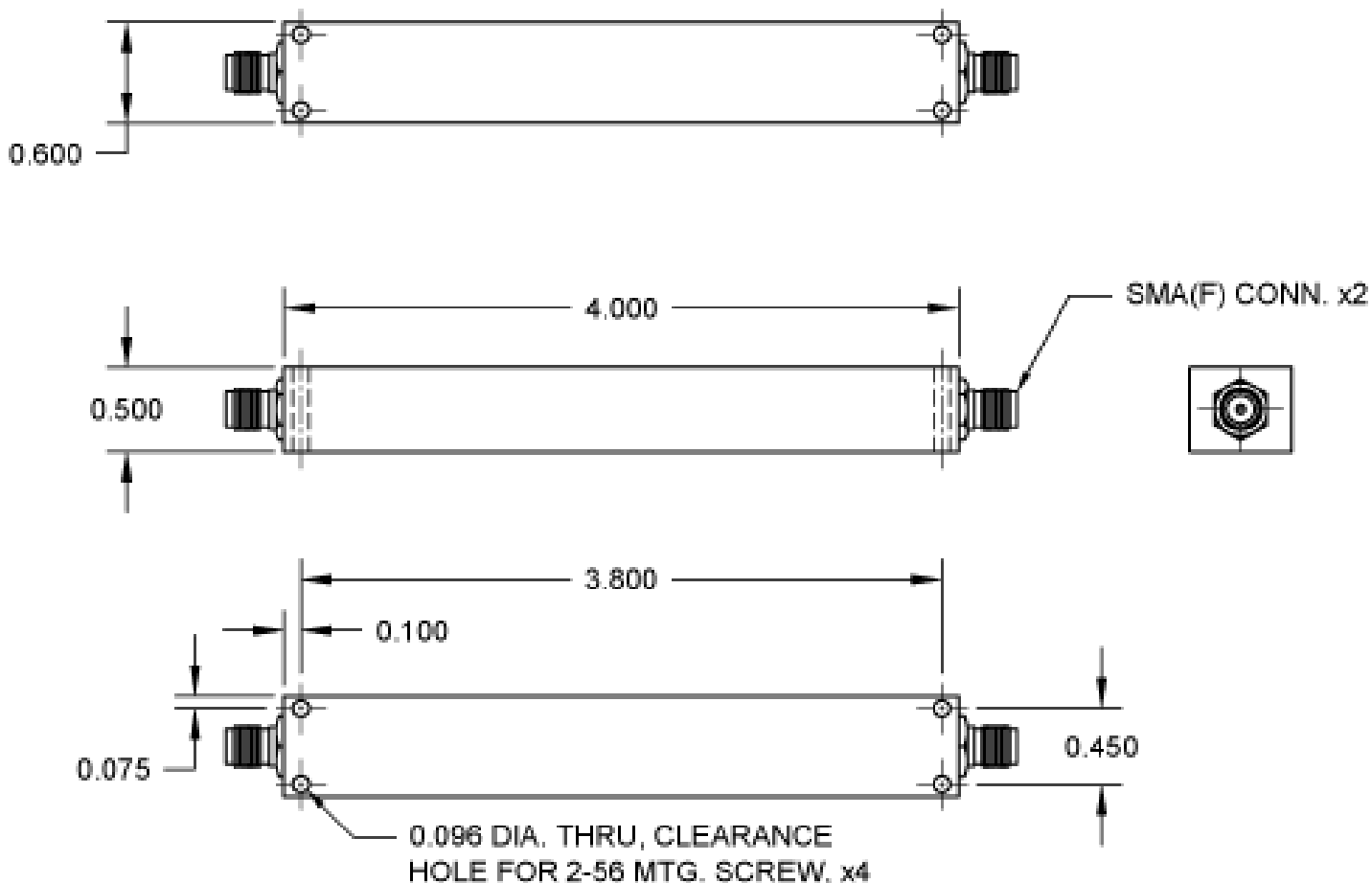



275-500 MHz LC Bandpass Filter

Part Number: AE387B10680



Plot:

A144.lad 001 5, 2010 Attenuation/Return Loss

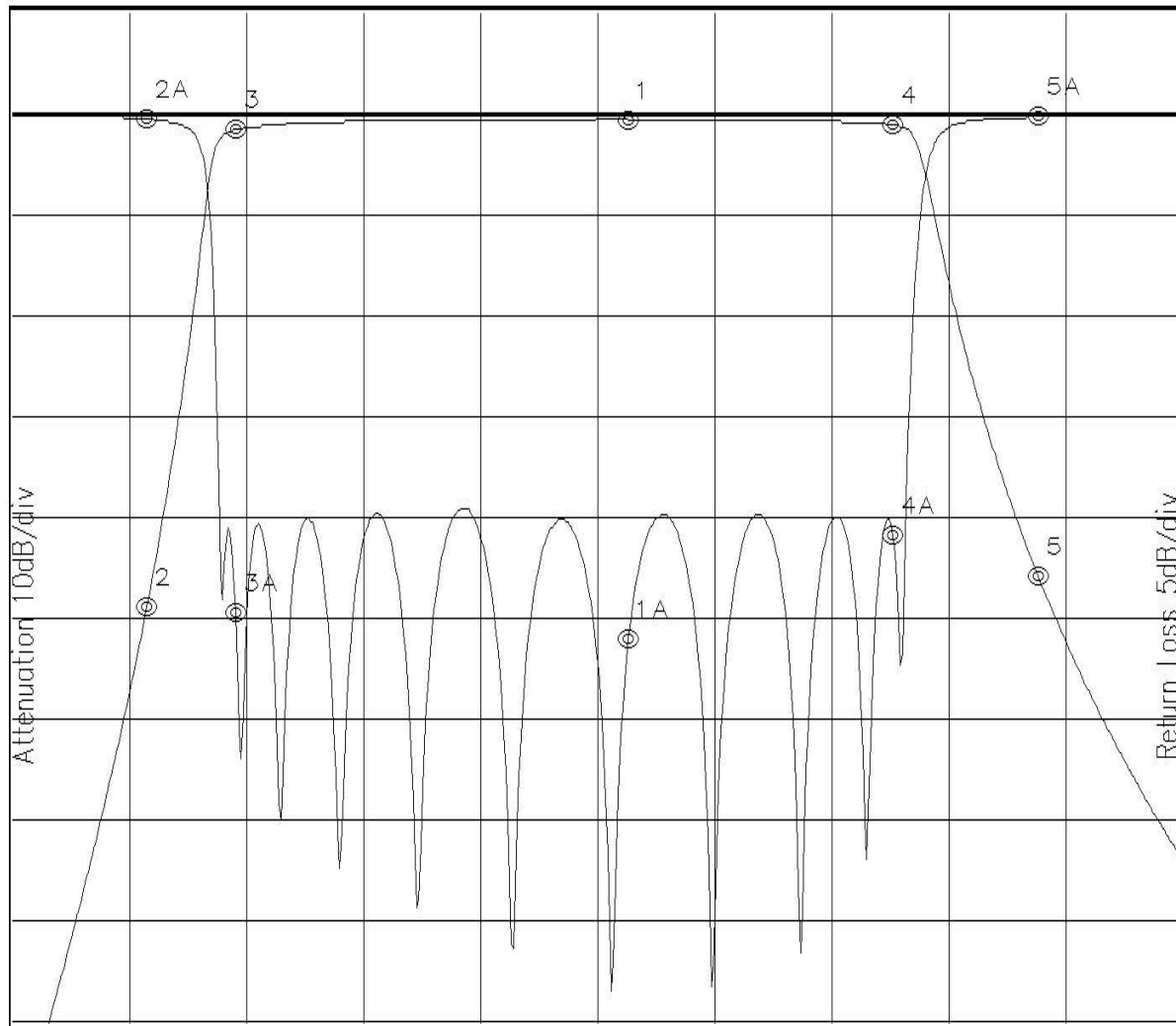

Attenuation Start: 200.0MHz Stop: 600.0MHz Return Loss Start: 200.0MHz Stop: 600.0MHz

Marker 1 Freq 410.01MHz Atten -0.544dB
 Marker 2 Freq 245.23MHz Atten -49.182dB
 Marker 3 Freq 275.60MHz Atten -1.560dB
 Marker 4 Freq 500.48MHz Atten -1.079dB
 Marker 5 Freq 550.24MHz Atten -46.137dB

Marker 1A Freq 410.01MHz Ret Loss -26.197dB
 Marker 2A Freq 245.23MHz Ret Loss -0.237dB
 Marker 3A Freq 275.60MHz Ret Loss -24.844dB
 Marker 4A Freq 500.48MHz Ret Loss -20.959dB
 Marker 5A Freq 550.24MHz Ret Loss -0.146dB